



# Invitation to Tender

CITY OF KENORA

## **INVITATION TO TENDER / ADVERTISEMENT**

Sealed Tenders for:  
Moncrief Construction Sports Centre Pool Disinfection Systems

Tender Number: 733-001-22

Will be received  
by:

**City of Kenora**  
(the "City")

at:

**1 Main Street South**  
**Kenora, ON P9N 3X2**  
**Attention: Kelly Galbraith, Deputy City Clerk**

Time and date for Tender Closing is:

11:00:00 a.m. CST/CDT on July 9, 2026 (the "Tender Closing")

1. The work to be undertaken generally involves, but is not necessarily limited to pool disinfection chemical treatment systems upgrades across four (4) bodies of water/ pools (the "Work") as attached to these Instructions to Tenders.
2. The CITY's consultant for the Project is Stantec.
3. The Successful Bidder shall achieve substantial performance of the Work for the Project by August 17, 2026.
4. The drawings and specifications for the Project can be obtained from Tino Mpofu, City of Kenora Project Manager, at [tmpofu@kenora.ca](mailto:tmpofu@kenora.ca).
5. All written inquiries regarding the technical aspects of the drawings and specifications for the Work shall be emailed to Tino Mpofu, City of Kenora Project Manager, at [tmpofu@kenora.ca](mailto:tmpofu@kenora.ca), however the bidder(s) acknowledge and agree that the CITY does not have an obligation to provide a response to any written inquiry and that it is in the sole and unfettered discretion of the CITY to provide any written response to a written inquiry. Telephone inquiries and email inquiries will not be replied to.
6. Submission of a tender by a Bidder gives the CITY the right to require the Bidder to execute the contract to perform the Work as set out within the tender documents. Tenders may not be withdrawn after the Tender Closing and will be irrevocable and open for acceptance by the CITY for a period of sixty (60) days following the end of the day of the Tender Closing. The Successful Bidder will be notified in writing of the award of the Tender when the CITY delivers a letter of intent to the Successful Bidder.



# **INSTRUCTIONS TO TENDERERS**

**CITY OF KENORA**

---

# INSTRUCTIONS TO TENDERERS

## 1 BACKGROUND

- 1.1 The City of Kenora (the "CITY") is seeking tenders for pool disinfection chemical treatment systems upgrades across four (4) bodies of water/pools (the "Work") as more particularly set out in Appendix "Three (3)" attached to these Instructions to Tenderers.
- 1.2 The Work under this Contract excludes the demolition of existing pool filtration systems and associated piping serving the leisure pool, competition pool, tot pool and hot tub. The Work also excludes the supply and installation of new pool filtration systems including all associated piping, valves, and appurtenances for all bodies of water.
- 1.3 The CITY will receive sealed tenders until 11:00:00 a.m. CST/CDT on July 9<sup>th</sup>, 2026, ("Tender Closing"). Faxed tenders will not be accepted and will be returned to the Tenderer.

## 2 SUBMISSION OF TENDERS

- 2.1 Each Tender shall be addressed to the CITY in a sealed envelope clearly marked with the Tenderer's name, address and tender number. The sealed envelope containing the Tender shall be delivered before the Tender Closing to the CITY in accordance with the Invitation to Tender and the Instructions to Tenderers at:

**City of Kenora  
1 Main Street South  
Kenora, ON P9N 3X2  
Attention: Heather Pihulak, City Clerk**

- 2.2 In the event of a dispute or issue about whether or not a tender complies with the Instructions to Tenderers, the CITY reserves the right to retain and open a copy of the tender in question in order to seek and obtain a legal opinion in relation thereto. The opening of a tender does not in any way constitute an admission by the CITY as to the compliance, or not, of the subject tender.

## 3 TENDER FORM

- 3.1 Each Tenderer shall submit a complete tender on the Tender Form which forms part of the Tender Documents with the blank spaces filled in. The tender sum must be written in words as well as figures, and must be for a sum in Canadian Dollars including all tariffs, freight, duties and taxes other than the Goods and Services Tax which must be shown as a separate amount unless otherwise specifically stipulated (hereinafter referred to as the "Tender Sum"). In the event of a discrepancy between an amount written in words and an amount written in figures, the amount written in words shall be deemed the intended amount. Tenders shall be written in English.
- 3.2 Notwithstanding the foregoing, the CITY shall be entitled to accept a Tender in such form as the CITY in its sole and unfettered discretion deems acceptable irrespective

of irregularities whether of a trivial or substantial nature, or whether the Tender is noncompliant in a trivial or substantial manner.

- 3.3 The CITY shall not be obligated to accept Tenders that are unsigned, incomplete, conditional, illegible, unbalanced, obscure, contain irregularities of any kind, or contain mathematical or calculation errors of any kind. On Unit Price Tenders, if there is a discrepancy found between the unit price and the extended amount, the unit price shall be deemed to represent the intention of the Tenderer. Discrepancies between words and figures will be resolved in favour of the words. Discrepancies between the indicated sum of any figures and the correct sum thereof will be resolved in favour of the correct sum. Any discrepancies between the Tender Form and a post Tender Closing submission required by the Tender Documents will be resolved in favour of the post Tender Closing submission.
- 3.4 Tenders shall not be withdrawn, modified or clarified after being delivered in accordance with the Tender Documents unless such withdrawal, modification or clarification is made in writing and actually received by Heather Pihulak of the CITY prior to the Tender Closing. Any withdrawal, modification or clarification of the Tender must be followed by a letter of confirmation signed and sealed in the same manner as the Tender and delivered to the address for the CITY in the Invitation to Tender within 48 hours of the Notice of the Withdrawal, Modification or Clarification.

#### **4 THE FREEDOM OF INFORMATION AND PROTECTION OF PRIVACY ACT**

- 4.1 All documents submitted to the CITY will be subject to the protection and disclosure provisions of Ontario's *Freedom of Information and Protection of Privacy Act* ("FOIP"). FOIP allows persons a right of access to records in the CITY's custody or control. It also prohibits the CITY from disclosing the Tenderer's personal or business information where disclosure would be harmful to the Tenderer's business interests or would be an unreasonable invasion of personal privacy as defined in sections 17 and 21 of FOIP. Tenderers are encouraged to identify what portions of their submissions are confidential and what harm could reasonably be expected from its disclosure. However, the CITY cannot assure Tenderers that any portion of the Tenderer's documents can be kept confidential under FOIP.

## **5 TENDER DOCUMENTS**

5.1 The documents for the Tender are:

- Invitation to Tender
- Instructions to Tenderers
- Appendix 1 Additional Instructions to Tenderers
- Appendix 2 Tender Forms
- Appendix 3 General Specifications
- Appendix 4 Drawings

(hereinafter collectively referred to as the “Tender Documents”)

By submitting its Tender, the Tenderer acknowledges and agrees that it has received and reviewed the Tender Documents.

## **6 VARIATION IN TENDER DOCUMENTS AND NO IMPLIED OBLIGATIONS**

6.1 The Tenderer shall carefully examine the Tender Documents. Any errors, omissions, discrepancies or clauses requiring clarification shall be reported in writing to the CITY at least 10 calendar days prior to the Tender Closing. Where necessary the CITY shall respond to reported errors, omissions, discrepancies or clauses requiring clarification by way of Addenda.

6.2 Should a Tenderer fail to report any such errors, omissions, discrepancies or clauses requiring clarification at least 10 calendar days prior to the Tender Closing, the CITY shall be the sole judge as to the intent of the Tender Documents.

6.3 No implied obligation of any kind by or on behalf of the CITY shall arise from anything in the Tender Documents, and the express covenants and agreements contained in the Tender Documents and made by the CITY, are and shall be the only covenants and agreements that apply.

6.4 Without limiting the generality of Article 6.3, the Tender Documents supercede all communications, negotiations, agreements, representations and warranties either written or oral relating to the subject matter of the Tender made prior to the Tender Closing, and no changes shall be made to the Tender Documents except by written Addenda.

## **7 ADDENDA**

7.1 Any changes to the Tender shall be in writing in the form of Addenda. Any Addenda issued to the Tender shall form part of the Tender Documents, whether or not the receipt of same has been acknowledged by a Tenderer, and the cost for doing the work therein shall be included in the Tender Sum. Verbal representations shall not be binding on the CITY nor form part of the Tender Documents. Technical inquiries into the meaning or intent of the Tender Documents must be submitted in writing to the person identified in Article 2.1 of the Instructions to Tenderers.

## 8 TENDER

- 8.1 Tenderers submitting Tenders shall be actively engaged in the line of work required by the Tender Documents and shall be able to refer to work of a similar nature performed by them. They shall be fully conversant with the general technical phraseology in the English language of the lines of work covered by the Tender Documents.
- 8.2 Each Tenderer shall review the Tender Documents provided by the CITY and confirm that it is in possession of a full set of Tender Documents when preparing its Tender.
- 8.3 Tenders shall be properly executed in full compliance with the following requirements:
- a) The signatures of persons executing the Tender must be in their respective handwriting; and
  - b) If the Tender is made by a limited company, the full name of the company shall be accurately printed immediately above the signatures of its duly authorized officers and the corporate seal shall be affixed;
  - c) If the Tender is made by a partnership, the firm name or business name shall be accurately printed above the signature of the firm and the Tender shall be signed by a partner or partners who have authority to sign for the partnership;
  - d) If the Tender is made by an individual carrying on business under the name other than its own, its business name together with its name shall be printed immediately above its signature or
  - e) If the Tender is made by a sole proprietor who carries on business in its own name, the proprietor shall print its name immediately below its signature.
- 8.4 Tenders received from agents representing principals must be accompanied by a Power of Attorney signed by the said principals showing that the agents are duly authorized to sign and submit the Tender and have full power to execute the Contract on behalf of their principals. The execution of the Contract will bind the principals and have the same effect as if it were duly signed by the principals.

## 9 TENDER DEPOSIT

- 9.1 The Tenderer is required to submit with its Tender, a Consent of Surety and a Bid Bond in a form acceptable to the CITY, or in lieu of a Bid Bond, a Tenderer may submit, along with a Consent of Surety, a certified cheque or an irrevocable letter of credit in favour of the CITY equal to 10% of the Tender Sum as a guarantee that, if awarded the contract for the Work, the Tenderer will execute a contract.
- 9.2 The Bid Bonds, certified cheques or irrevocable letters of credit of the unsuccessful Tenderers shall be returned as soon as possible after the Contract has been duly executed by the Successful Tenderer.

- 9.3 The CITY will not pay any interest on money furnished as security.
- 9.4 The Bid Bond and Consent of Surety shall be issued by a Surety Company licensed in the Province of Ontario and satisfactory to the CITY.

## **10 PERFORMANCE AND LABOUR AND MATERIAL PAYMENT BONDS**

- 10.1 The Successful Tenderer shall be required to furnish at its own expense a Performance Bond and Labour and Materials Payment Bond. For the purposes of this Article, both of these bonds shall be referred to as the "Bonds".
- 10.2 The Performance Bond shall guarantee the faithful performance of the Contract, and in default thereof, shall protect the CITY against any losses or damage arising by reason of failure of the Successful Tenderer to faithfully perform the Contract.
- 10.3 The Bonds are to be issued by a Surety Company licensed in the Province of Ontario and satisfactory to the CITY in the amount of 50% of the Contract Price and 50% of the contract price for the Labour and Materials Payment Bond.
- 10.4 The Performance Bond shall remain in force as a Maintenance Bond for the Warranty Period as defined in the Contract.
- 10.5 The Bonds shall be in the form set out in the Tender Documents or in such other form as may be acceptable to the CITY.
- 10.6 The CITY may consider alternate forms of security in lieu of the Bonds. The Tenderer shall make known any alternative form of security it wishes the CITY to consider and obtain the CITY's approval prior to submitting a Tender.
- 10.7 The Successful Tenderer shall provide all required Bonds to the CITY no later than 10 working days after receipt of the Letter of Intent from the CITY provided in accordance with Article 16.
- 10.8 The Successful Tenderer shall supply all required Bonds before any Work is undertaken by the Successful Tenderer.
- 10.9 No payment shall be made by the CITY to the Successful Tenderer for any of the Work performed by the Successful Tenderer until the required Bonds have been provided.

## **11 INSURANCE**

- 11.1 The Tender shall be accompanied by a Certificate of Insurance, certifying that the insurance as required by the Contract, is in place or, if the required insurance is not in place, by a Letter of Insurability or Undertaking of Insurance in standard form from the Tenderer's Insurance Broker certifying that the required insurance will be issued to the Tenderer if the Tenderer is the Successful Tenderer.
- 11.2 The Successful Tenderer shall be required to secure and maintain at its own expense the insurance provided for in the Contract.

- 11.3 The Successful Tenderer shall provide all required insurance to the CITY no later than 10 working days after receipt of a Letter of Intent from the CITY provided in accordance with Article 16.

## **12 COMMENCEMENT AND COMPLETION OF WORK**

- 12.1 The Successful Tenderer shall commence the Work within 10 working days after receipt of the executed contract from the CITY and shall complete the Work by the dates specified in the Contract.

## **13 SITE CONDITIONS**

- 13.1 The Tenderer is responsible for inspecting the site(s) of the Work and for making whatever inquiries or arrangements necessary for it to become fully informed of the nature of the site(s) of the Work, including the soil structure and topography of the site(s), and of the Work to be performed and all matters which may in any way affect the Work. Without limiting the foregoing, by the submission of its Tender, the Tenderer acknowledges that it has investigated and satisfied itself as to:

- a) the nature of the Work;
- b) the location and all conditions relating to the location of the Work including, but not limited to, accessibility, general character, surface and sub-surface conditions, soil structure, utilities, road, uncertainties of seasonal weather and all other physical, topographical, geological and geographic conditions;
- c) the general character, conditions, laws and restrictions applicable to the Work that might affect the performance of the Work;
- d) all environmental risks, conditions, laws and restrictions applicable to the Work that might affect the Work; and
- e) the magnitude of the work required to execute and complete the Work.

- 13.2 The Tenderer is fully responsible for obtaining all information required for the preparation of its Tender and for the execution of the Work. The CITY is not responsible for undertaking any investigations to assist the Tenderer. Any information, plans, drawings, shop drawings or existing equipment or facilities, photos of the original construction, reports or other documents which are not included or referred to in the Tender Documents (the "Non-Tender Information"), form no part of this Tender. The CITY and the CITY's Consultants assume no responsibility of any kind whatsoever arising from or relating to its failure to include or refer to such Non-Tender Information. Tenderers who obtain or rely upon such Non-Tender Information or other documents, do so entirely at their own risk.

- 13.3 The Tenderer's obligation to become familiar with the information described in Article 13.1 is not lessened or discharged by reason of any technical reports, including soils reports or data, test hole drilling reports or other soils information, made available or supplied in conjunction with the tendering process. Any technical reports so provided are for information only and neither the CITY nor the CITY's Consultants accept or assume any responsibility for the contents or accuracy of such technical reports and the Tenderer agrees that the CITY, the CITY's Consultants and their representatives shall not be liable in any way to the Tenderer in respect of such technical reports. The Tenderer further agrees that it shall not

rely upon any oral information provided to it by the CITY, the CITY's Consultants or their representatives.

#### **14 PRIME COST AND CONTINGENCY SUMS**

- 14.1 The Tenderer shall include in its Tender Sum any prime cost sums or contingency sums. The Harmonized Sales Tax shall be shown as a separate amount.

#### **15 PERMITS AND INSPECTIONS**

- 15.1 The Tenderer shall include in its Tender Sum the cost of permits and inspections required by any governmental or other authority having jurisdiction or as required to fully perform the Work in accordance with the Contract.

#### **16 SUCCESSFUL TENDERER**

- 16.1 Award of Contract by the CITY occurs once the Tenderer receives an executed contract.
- 16.2 Following the receipt of the executed contract, the Successful Tenderer shall provide the Performance Bond and Labour and Material Payment Bond within the time required in Article 10.7. The Successful Tenderer shall also provide a Certificate of Insurance unless previously provided.
- a) Upon the Successful Tenderer complying with the requirements of both Articles 16.2 and 16.4, the certified cheque or Bid Bond or irrevocable letter of credit, as the case may be, shall be returned to the Successful Tenderer.
  - b) If the Successful Tenderer fails to comply with either or both of the requirements of Articles 16.2 and 16.4, the certified cheque or Bid Bond or irrevocable letter of credit, as the case may be, shall be forfeited to the CITY as compensation for damages the CITY may suffer.
- 16.3 The forfeiture of a Successful Tenderer's certified cheque or Bid Bond or irrevocable letter of credit shall not be construed as a waiver of any rights or remedies which the CITY may have against such Tenderer for loss or damages incurred or suffered in excess of the amount of such certified cheque or Bid Bond or irrevocable letter of credit.
- 16.4 Within 10 working days of receipt of the Contract from the CITY, the Successful Tenderer shall duly execute the Contract and return the Contract to the CITY.
- 16.5 Within five (5) working days of receipt of the executed contract in accordance with Article 16.1, the Successful Tenderer shall submit a proposed Construction Schedule showing the anticipated time of commencement and completion of each of the various operations to be performed under the Contract.
- 16.6 The Construction Schedule shall identify the anticipated commencement and completion dates for each activity, critical path activities, and any long-lead procurement items that may impact the completion of the Work. At a minimum, the Construction Schedule shall include:

- a) Shop drawing and product data preparation and submission;
- b) Shop drawing review;
- c) Procurement and delivery of all major equipment and long-lead items;
- d) Building permit and regulatory approval milestones, where applicable;
- e) Mobilization and site preparation;
- f) Removal and disposal of existing equipment;
- g) Installation of new equipment and associated mechanical, electrical, and control systems;
- h) Testing, commissioning, training;
- i) Substantial Performance and Total Performance milestones.

## **17. TENDER EVALUATION CRITERIA**

- 17.1 Each Tender will be evaluated on the basis of the criteria listed below and the CITY will have the sole and unfettered discretion to award up to the maximum number of points for each criteria as listed below. By submitting a Tender, the Tenderer acknowledges and agrees that the CITY has, and it is hereby entitled to exercise, the sole and unfettered discretion to award the points for the evaluation of the noted criteria.
- 17.2 By submitting its Tender, each Tenderer acknowledges and agrees that it waives any right to contest in any legal proceedings, the decision of the CITY to award points in respect of the criteria noted below. The criteria and the maximum number of points for each criteria are as follows:

Price	100
Total Points	100

## **18 WORKERS' COMPENSATION**

- 18.1 Each Tenderer is to submit with its Tender, a letter of account from the Workers' Compensation Board – Ontario. This letter is to be current and not dated 14 calendar days prior to the Tender Closing.
- 18.2 The Tenderers who do not have an account with the Workers' Compensation Board- Ontario shall provide with their Tender evidence of a subcontractor or other company that will carry such coverage on their behalf.

- 18.3 If the Tenderer is performing work in any exempt industry within the meaning of the Workers Compensation Board Act (the "WCB Act") and does not carry coverage, the Tenderer acknowledges that
- 18.3.1 the CITY is subject to a deeming order under s. 14(2) of the WCB Act (the "Deeming Order"); and
  - 18.3.2 the Deeming Order states that all of the Tenderer's employees, directors, proprietors, partners or employees are deemed to be CITY employees for the purposes of the WCB Act while performing work for the CITY; and
  - 18.3.3 the effect of the Deeming Order is that the Tenderer's employees, directors, proprietors and partners who are injured while performing work for the CITY under the Contract, have no right to sue anyone and are limited to a claim under the WCB Act.
- 18.4 The Tenderer shall communicate the existence and effect of the Deeming Order to all of its employees, directors, proprietors, partners or employees.
- 18.5 The CITY may reject any Tender which fails to comply with the provisions set out in Article 18.

## **19 REGISTRATION**

- 19.1 Prior to commencing the Work, the Successful Tenderer shall obtain all authorizations required by the laws of the Province of Ontario and of the Country of Canada enabling it to carry on business to complete the Work required under the Contract. Failure to be properly authorized shall entitle the CITY to forthwith terminate the Contract without compensation.

## **20 TENDERS EXCEEDING BUDGET**

- 20.1 In addition to the rights contained within Article 20 herein, if the Tender Sum of every Tenderer exceeds the amount the CITY has budgeted for the Work, the CITY may reject all Tenders or attempt to negotiate a lower price with the Tenderer who, in the sole and unfettered discretion of the CITY, has submitted the most advantageous Tender.
- 20.2 Each Tenderer acknowledges and agrees that the CITY has the sole and unfettered discretion to employ any criteria in order to determine the Tender most advantageous to the CITY, that the CITY has no obligation to neither disclose such criteria nor employ the criteria listed outlined in Article 17 Tender Evaluation Criteria.
- 20.3 By submitting its Tender, each Tenderer waives its right to contest in any action, application, case or legal proceeding in any court, the decision which the CITY may pursue under Article 20.1 and 20.2 herein.
- 20.4 If the Tender Sum of every Tenderer exceeds the amount budgeted for the Work and the CITY negotiates with the Tenderer who has submitted the Tender considered most advantageous to the CITY:

20.4.1 All statements made by either side in the course of negotiation are without prejudice and confidential;

20.4.2 In particular, the CITY's attempt to negotiate with such Tenderer does not constitute a rejection of its Tender; and

20.4.3 The CITY will not attempt to obtain a lower price for the same work that the Tenderer originally bid on, but may attempt to obtain a lower price for an altered scope of work. In no event will the CITY be obliged to disclose the amount budgeted for the Work.

## **21 CERTIFICATE OF RECOGNITION ("C.O.R.") SAFETY PROGRAM REQUIREMENT**

21.1 Unless otherwise stated, Tenders will only be considered when the Tenderer, prior to Tender Closing, has either full certification in the Ontario Labour approved Certificate of Recognition ("C.O.R.") Program appropriate to their industry or a temporary letter of certification issued by the Infrastructure Health & Safety Association or other appropriate industry association.

21.2 Certification shall be evident by inclusion of the Tenderers name on the Infrastructure Health & Safety Association ("I.H.S.A.") C.O.R. certification list current at the Tender Closing, or submission of a copy of the Ontario Labour Certificate of Recognition or a temporary letter of certification with the Tender.

21.3 The CITY will assume no liability for the non-inclusion of any Tenderer on the I.H.S.A. C.O.R. certification lists for any reason whatsoever.

21.4 The CITY reserves the right to terminate the Contract during the course of which the Contractor is decertified from the C.O.R. program or has their temporary letter of certification expire.

21.5 The CITY may reject any Tender which fails to comply with the provisions set out in Article 21.

## **22 CANADIAN FREE TRADE AGREEMENT**

22.1 The provisions of the Canadian Free Trade Agreement ("CFTA") apply to this Tender.

## **23 ACCEPTANCE OR REJECTION OF TENDERS**

23.1 As it is the purpose of the CITY to obtain the Tender most suitable and most advantageous to the interests of the CITY, and notwithstanding anything else contained within the Tender Documents, the CITY reserves the right, in its sole and unfettered discretion, to reject or accept any Tender, including the right to reject all Tenders. Without limiting the generality of the foregoing, any Tender which

a) is incomplete, obscure, irregular or unrealistic;

b) is non-compliant in a trivial/immaterial or substantial/material manner, or conditional;

- c) has erasures or corrections;
- d) omits a price on any one or more items in the Tender;
- e) fails to complete the information required in the Tender;
- f) is accompanied by an insufficient certified cheque, irrevocable letter of credit or by a Bid Bond in an unsatisfactory form,

may at the CITY's sole and unfettered discretion be rejected or accepted. Further, a Tender may be rejected or accepted on the basis of the CITY's unfettered assessment of its best interest, which includes the CITY's unfettered assessment as to a Tenderer's past work performance for the CITY or for anyone else or as to a Tenderer's financial capabilities, completion schedule, or ability to perform the Work, or the CITY's desire to reduce the number of different contractors on the location of the Work at any given time. The CITY reserves the right to negotiate after Tender Closing time with the Tenderer that the CITY deems has provided the most advantageous Tender; in no event will the CITY be required to offer any modified terms to any other Tenderer prior to entering into a Contract with the successful Tenderer and the CITY shall incur no liability to any other Tenderers as a result of such negotiation or modification.

## **24 LAW AND FORUM OF TENDER**

24.1 The law to be applied in respect of the Tender Documents and the Contract shall be the law of the Province of Ontario and all civil actions commenced in relation to the Tender Documents or Contract shall be adjudicated by the Courts of the Province of Ontario and by submitting Tenders, Tenderers are taken to have agreed to attorn to the jurisdiction of the Courts of the said Province.

## **25 ACCEPTANCE PERIOD**

25.1 The Tender shall be irrevocable and open for acceptance by the CITY for the period of time contained in the Invitation to Tender, namely, sixty (60) days following the end of the day of the Tender Closing. The time and date of the Tender Closing is as defined in the Invitation to Tender.



**CITY OF KENORA  
REQUEST FOR TENDER**

**ITT# 733-001-22**

**APPENDIX 1  
ADDITIONAL INSTRUCTIONS TO  
TENDERERS**

# ADDITIONAL INSTRUCTIONS TO TENDERERS

## 1 Tender Timelines

1.1 The following is the schedule for the bid call:

Issue Date of Request for Tender	June 22, 2026
Site Visit (Optional)	June 25, 2026, 10:00 (CDT)
Deadline for Questions	July 2, 2026, 16:00 (CDT)
Deadline for Issuing Addenda	July 6, 2026, 16:00 (CDT)
Tender Closing	July 9, 2026, 11:00 (CDT)

## 2 Tender Inquiries and Addenda

2.1 All questions or requests for clarification regarding this Tender must be submitted by email only to the following representatives:

2.1.1 Brady Kallert: [brady.kallert@stantec.com](mailto:brady.kallert@stantec.com)

2.1.2 Tino Mpofu: [tmpofu@kenora.ca](mailto:tmpofu@kenora.ca)

2.2 Tenderers are responsible for ensuring they have received all Addenda issued by the CITY prior to Tender Closing.

## 3 Site Visits

- 3.1 A optional site visit for Tenderers will be held on June 25<sup>th</sup>, 2026, commencing at 10:00 am. CDT.
- 3.2 Attendees to confirm attendance with Tino Mpofu via email at [tmpofu@kenora.ca](mailto:tmpofu@kenora.ca).
- 3.3 Attendees are to assemble in the lobby area of the Moncrief Sports Centre located at 18 Mike Richards Way, Kenora, Ontario.
- 3.4 Bidders participating in the Site Walkthrough are required to sign in.

## 4 Permits and Inspections

4.1 Without limiting the generality of Article 15.1 of the Instructions to Tenderers, the Successful Tenderer is not required to obtain building permits as the City is applying for this. The contractor however is expected to take on ownership of the building permit upon award and coordinate all inspections required by the authority having jurisdiction.

## 5 Tenderer's Preliminary Construction Schedule

5.1 Tenderers shall submit a preliminary Construction Schedule identifying major milestones, anticipated equipment lead times, and the Tenderer's proposed completion date.



**CITY OF KENORA  
REQUEST FOR TENDER**

**ITT# 733-001-22**

**APPENDIX 2  
TENDER FORMS**

## TENDER FORM

Tender Number: \_\_\_\_\_

Tender Title: \_\_\_\_\_

We, \_\_\_\_\_  
(Company)

of \_\_\_\_\_  
(Business Address)

having examined the Tender Documents as issued by: the City of Kenora (the "City"), and having visited the site(s) of where the Work is required to be undertaken; hereby offer to enter into a Contract to perform the Work required by the Tender Documents for the Tender Sum as follows:

Item No.	Item	Description of item	Amount (\$)
1	Mobilization & Demobilization	Includes all mobilization, site setup, temporary facilities, protection measures, access equipment, and final demobilization required to complete the work. Price shall include all labour, materials, equipment, and incidentals required to complete the respective scope of work in full.	
2	Leisure Pool Mechanical Room	Includes demolition of existing chemical treatment equipment and associated piping, and supply and installation of new chemical treatment systems, piping, valves, controls, appurtenances, and all required connections and tie-ins.	
3	Competition Pool Mechanical Room	Includes demolition of existing chemical treatment equipment and associated piping, and supply and installation of new chemical treatment systems, piping, valves, controls, appurtenances, and all required connections and tie-ins.	
4	Tot Pool System	Includes demolition of existing chemical treatment equipment and associated piping, and supply and installation of new chemical treatment systems, piping, valves, controls, appurtenances, and all required connections and tie-ins.	
5	Hot Tub System	Includes demolition of existing chemical treatment equipment and associated piping, and supply and installation of new chemical treatment systems, piping, valves, controls, appurtenances, and all required connections and tie-ins.	
6	Testing and Commissioning	Includes pressure testing of piping systems, flushing, startup, commissioning of chemical systems, and functional verification to demonstrate proper operation.	
7	Contractor Supplied Pool Chemicals	Includes the provision and supply of initial pool chemicals required for startup and commissioning, including but not limited to calcium hypochlorite and sodium bisulfate, as required to achieve initial water balance and operational conditions.	

\* Price shall include all labour, materials, equipment, and incidentals required to complete the respective scope of work in full.

1. Sub-Total (excluding GST) \$ \_\_\_\_\_

2. HST \$ \_\_\_\_\_

3. Total \$ \_\_\_\_\_

in Canadian funds, which price includes any specified cash and contingency allowances and the applicable taxes in force at this date and except as may be otherwise provided in the Tender Documents.

**Appendices to Tender Form:**

The information required by the Instructions to Tenderers is provided in the attached Appendices and forms an integral part of this Tender.

- APPENDIX ONE (1) ADDITIONAL INSTRUCTIONS TO TENDERERS
- APPENDIX TWO (2) TENDER FORMS
- APPENDIX THREE (3) GENERAL SPECIFICATIONS
- APPENDIX FOUR (4) DRAWINGS

**Declarations:**

We hereby acknowledge and declare that:

- (a) we agree to perform the Work in compliance with the required completion schedule stated in the Contract;
- (b) no person, firm or corporation other than the undersigned has any interest in this Tender or in the proposed Contract for which this Tender is made;

Signatures:

Signed, sealed and submitted for and on behalf of:

Company: \_\_\_\_\_  
*(Name)*

\_\_\_\_\_  
*(Street Address or Postal Box Number)*

\_\_\_\_\_  
*(City, Province & Postal Code)*

*(Apply SEAL above)*

Signature: \_\_\_\_\_

Name & Title: \_\_\_\_\_  
*(Please Print or Type)*

Witness: \_\_\_\_\_

Dated at \_\_\_\_\_ this \_\_\_\_\_ day of \_\_\_\_\_, 20\_\_



**CITY OF KENORA  
REQUEST FOR TENDER**

**ITT# 733-001-22**

**APPENDIX 3  
GENERAL SPECIFICATIONS**

**Appendix A  
SUBCONTRACTORS**

Project Number: 115425040  
Project: 1.1 Pool Disinfection System Replacement  
Bidder: \_\_\_\_\_

\_\_\_\_\_ The following is the list of Subcontractors referred to in the Bid for the above-named project.

Demolition	_____
Plumber/Pipefitter	_____
Controls Technician	_____
Mechanical	_____
Electrical	_____
_____	_____
_____	_____
_____	_____
_____	_____
_____	_____
_____	_____
_____	_____

*(List additional Major Subcontractors as necessary)*

**Appendix B  
 UNIT PRICES**

Project Number: 115425040  
 Project: 1.1 Pool Disinfection System Replacement

Bidder: \_\_\_\_\_

The following are our UNIT PRICES for the Units of Work listed hereunder. The Unit Prices apply to performing the Units of Work only during the time schedule for such work in the project schedule.

PRICES DO NOT INCLUDE THE HARMONIZED SALES TAX (HST)

Item No.	Unit of Work	Measurement Unit	Unit Price (\$)	
			Addition	Deduction
1	<b>Removal and disposal of existing pipe</b>	Per foot		
2	<b>Supply and install of new PVC piping Include for all sizes required for work</b>	Per foot		
3	<b>Supply and install of new SS piping Include for all sizes required for work</b>	Per foot		
4	<b>Additional electrical conduit</b>	Per foot		
5	<b>Additional Electrical Cable Install</b>	Per foot		
6	<b>Commissioning Tech</b>	Per hour		
7	<b>Controls programming</b>	Per hour		

*(If Appendix 'C' is not used, put "Not Applicable" and initial bottom of page)*

**Appendix C  
ALTERNATIVES**

Project Number: 115425040  
Project: 1.1 Pool Disinfection System Replacement

Bidder: \_\_\_\_\_

The following are our ALTERNATIVE PRICES for the Work listed hereunder.  
Such Work and amounts are "NOT INCLUDED" in our Stipulated Price.

PRICES DO NOT INCLUDE THE HARMONIZED SALES TAX (HST)

Item No.	Description of Alternative Work	Effect on Stipulated Price (\$)	
		Addition	Deletion
1	<b>Leisure Pool Flocculant Deduction:</b>		
2	<b>Competition Pool Flocculant Deduction:</b>		
3	<b>Tot Pool Flocculant Deduction:</b>		
4	<b>Hot Tub Flocculant Deduction:</b>		

*(If Appendix 'D' is not used, put "Not Applicable" and initial bottom of page)*

**Appendix D  
ITEMIZED PRICES**

Project Number: 115425040  
Project: 1.1 Pool Disinfection System Replacement

Bidder: \_\_\_\_\_

The following are our ITEMIZED PRICES for the Work listed hereunder.  
Such Work and amounts are "INCLUDED" in our Stipulated Price.  
PRICES DO NOT INCLUDE THE HARMONIZED SALES TAX (HST)

Item No.	Description of Itemized Price	Amount (\$)
1	<b>Mobilization and Demobilization</b>	
2	<b>Leisure Pool System</b>	
3	<b>Competition Pool System</b>	
4	<b>Tot Pool System</b>	
5	<b>Hot Tub System</b>	
6	<b>Testing and Commissioning</b>	
7	<b>Contractor Supplied Pool Chemicals</b>	

*(If Appendix 'F' is not used, put "Not Applicable" and initial bottom of page)*

### **1.01 WORK OF THIS CONTRACT**

- .1 Work of this Contract comprises the following:
  - .1 Demolition of existing pool chemical treatment systems, and associated piping for the leisure pool, competition pool, tot pool, and hot tub
  - .2 Supply and installation of new chemical treatment systems and flocculation systems, including all associated piping, valving, and appurtenances for all bodies of water.
  - .3 Modifications to and integration with existing pool mechanical systems, including tie-ins, reuse of existing piping, and reconnection of equipment to remain.
  - .4 Provision of contractor-supplied chemicals required for system startup and commissioning.
  - .5 Testing, startup, and commissioning of all pool mechanical systems to ensure proper operation
  - .6 Work under this contract excludes demolition of existing pool filtration systems, and associated piping for the leisure pool, competition pool, tot pool, and hot tub
  - .7 Work under this contract excludes supply and installation of new pool filtration systems, including all associated piping, valving, and appurtenances for all bodies of water.
- .2 Municipal Address: 18 Mike Richards Way, Kenora, Ontario.

### **1.02 REFERENCES AND CODES**

- .1 Perform Work in accordance with the 2020 National Building Code of Canada (NBCC), Ontario Building Code 2024, and other codes of provincial or local application provided that in case of conflict or discrepancy, more stringent requirements apply.
- .2 Meet or exceed requirements of:
  - .1 Contract documents.
  - .2 Specified standards, codes and referenced documents.
- .3 Wherever codes, standards, regulations are referenced throughout the Contract Documents they mean the latest editions including amendments, supplements and revisions as of the date of bid closing.

### **1.03 CONTRACT METHOD**

- .1 The Agreement between Owner and Contractor and the General Conditions of the Contract for the project shall be the Standard Construction Document CCDC-2, 2020 Stipulated Price Contract as approved by the Canadian Construction Documents Committee.

### **1.04 CONSTRUCTION SCHEDULE**

- .1 The Date of Commencement of the Contract shall be the day following execution of the Contract.
- .2 Commence work at the Place of the Work within 10 working days after date of commencement of Contract.
- .3 Work may only begin on site after June 27, 2026
- .4 Attain Substantial Performance of the Work no later than August 17, 2026.
- .5 Attain Ready-For-Takeover no later than September 7, 2026.

- .6 There will be no bonus awarded for early completion of the Work.

**1.05 DIVISION OF WORK**

- .1 Division of the Work among Subcontractors and Suppliers is solely Contractor's responsibility. Consultant and Owner assume no responsibility to act as an arbiter to establish subcontract limits between Sections or Divisions of the Work.

**1.6 SPECIFICATION LANGUAGE AND STYLE**

- .1 Division 01 - General Requirements apply to the Work of all Sections in the project manual.
- .2 These Specifications are written in the imperative mood and in streamlined form. The imperative language is directed to Contractor, unless stated otherwise.
- .3 Complete sentences by reading "shall", " Contractor shall", "shall be", and similar phrases by inference. Where a colon (:) is used within sentences and phrases, read the words "shall be" by inference.
- .4 The word "shall" when used in the Specifications means "has a duty to."
- .5 Fulfill and perform all indicated requirements whether stated imperatively or otherwise.
- .6 When used in the context of a Product, read the word "provide" to mean "supply and install to result in a complete installation ready for its intended use".
- .7 Specification Addressing Scheme:

<b>1.01</b>	<b>ARTICLE</b>
.1	Paragraph
.1	Subparagraph
.1	Subparagraph
.1	Subparagraph
.1	Subparagraph

**1.7 CONTRACT DOCUMENTS FOR CONSTRUCTION PURPOSES**

- .1 The copyrights to all designs, Drawings, and Specifications are the property of Stantec Consulting Ltd. Reproduction or use for any purpose other than that authorized by Stantec is forbidden.
- .2 For trade contractor use, electronic copies of the Consultant's drawings may be available for purchase. Purchasers of electronic copies of the drawings will be required to sign an electronic file use agreement form prepared by Stantec Consulting Ltd. A copy of the form is available for viewing upon request.
- .3 Electronic copies of the Consultant's drawings may be purchased through the Contractor for the amount of \$250.00 for the first electronic file or drawing sheet requested plus an additional \$200.00 for each subsequent electronic file or drawing sheet requested at same time. Upon receipt of executed electronic file use agreement and payment, the Contractor will distribute electronic files to trade contractor and make reimbursement to Consultant.
- .4 Electronic copies of the Contract Drawings may only be available after award of Contract and will be current only up to the date they are issued for Bid. They will not include revisions made to the Contract Documents after Bid closing (e.g. addenda, change order, supplemental instruction).
- .5 Stantec reserves the right to refuse any and all requests for electronic documents.

**1.8 DOCUMENTS AT THE SITE**

- .1 Keep the following documents at Place of the Work, stored securely and in good order and available to Owner and Consultant in hard copy or electronic form:
  - .1 Current Contract Documents, including Drawings, Specifications and addenda.
  - .2 Change Orders, Change Directives, and Supplementary Instructions.
  - .3 Requests for Interpretation (RFI) including RFI log.
  - .4 List of Outstanding Shop Drawings.
  - .5 Reviewed Shop Drawings, Product data and samples.
  - .6 Field test reports and records.
  - .7 Construction progress schedule.
  - .8 Other Modifications to Contract.
  - .9 Copy of Approved Work Schedule.
  - .10 Meeting minutes.
  - .11 Manufacturer's certifications.
  - .12 Permits, inspection certificates, and other documents required by authorities having jurisdiction.
  - .13 Current as-built drawings.
  - .14 Safety Data Sheets (SDS) for all controlled Products.
  - .15 Health and Safety Plan and other safety related documents.
  - .16 Other documents as specified.

**END OF SECTION**

**1.01 SUMMARY**

- .1 Section Includes:
  - .1 Cash allowances carried by the Contractor.

**1.02 RELATED REQUIREMENTS**

- .1 CCDC 2-2020, Part 4 Allowances: For cash allowances.

**1.03 EXPENDITURE OF CASH ALLOWANCES**

- .1 Owner, through Consultant, will provide Contractor with documentation required to permit pricing of a cash allowance item.
- .2 Owner, through Consultant, may request Contractor to identify potential Suppliers or Subcontractors, as applicable, and to obtain at least three competitive prices for each cash allowance item.
- .3 Owner, through Consultant, may request the Contractor to disclose originals of all bids, quotations, and other price related information received from potential Suppliers or Subcontractors.
- .4 Owner, through Consultant, will determine by whom and for what amount each cash allowance item will be performed. Obtain Owner's prior written approval in the form of a Change Order before entering into a subcontract, amending an existing subcontract, or performing own forces work included in a cash allowance. Upon issuance of the Change Order, the Contractor's responsibilities for a cash allowance item shall be the same as for other work of the Contract.

**1.04 CASH ALLOWANCES FOR SERVICES**

- .1 Amount of each cash allowance includes:
  - .1 All costs related to the services, excluding Value Added Taxes.
  - .2 Subcontractor's and sub-Subcontractor's overheads and profits related to the cash allowance.
- .2 Amount of each cash allowance does not include Contractor's overhead and profit, and other related costs, which shall be included in the Contract Price and not in the cash allowance.
- .3 Cash Allowance Number 01: Existing Pipe modifications, tie-ins, and repairs.
  - .1 Allow the stipulated sum of \$10,000 for modifications to existing piping systems, including tie-ins, adjustments, and field coordination required to integrate new work with existing systems, as directed by the Consultant. Work under this allowance shall be carried out on a time-and-material basis:
    - .1 This allowance is intended to address unknown site conditions related to existing systems only and shall include reasonable repairs to existing piping or fittings where deterioration, corrosion, or deficiencies are identified during the Work that were not reasonably apparent prior to construction. Costs arising from damage to existing systems caused by the Contractor's operations, negligence, or improper work practices, including but not limited to breakage of piping or fittings, shall not be paid for under this allowance and shall be the sole responsibility of the Contractor.

**END OF SECTION**

**1.01 GENERAL**

- .1 Unit Price is a price that may be used to adjust the Contract Price for an addition or deletion of the Work.
- .2 Acceptance of Unit Prices is at the sole discretion of the Owner.
- .3 Submit complete and accurate prices for each Unit Price including overhead and profit, labour, materials, and equipment.
- .4 Referenced specification Sections stipulate pertinent requirements for products and methods to achieve the Work under each Unit Price.

**1.02 UNIT PRICES:**

- .1 Unit Price 01 - Removal and disposal of existing pipe:
 

.1 Unit Price shall be the combined removal and disposal (R&D) Unit Price for each foot of existing pipe.	Measurement Unit	S & I Unit Price
	ft	\$/ft
- .2 Unit Price 02 – Supply and install of new PVC piping include for all sizes required for work.:
 

.1 Unit Price shall be the combined Supply and Install (S&I) Unit Price for each foot of new PVC piping, a price shall be provided for each diameter used for the job.	Measurement Unit	S & I Unit Price
	ft	\$/ft
- .3 Unit Price 03 – Supply and install of new SS piping include for all sizes required for work.:
 

.1 Unit Price shall be the combined Supply and Install (S&I) Unit Price for each foot of new Stainless steel pipe, a price shall be provided for each diameter used for the job.	Measurement Unit	S & I Unit Price
	ft	\$/ft
- .4 Unit Price 04 – Additional electrical conduit.:
 

.1 Unit Price shall be the combined Supply and Install (S&I) Unit Price for each foot of new electrical conduit..	Measurement Unit	S & I Unit Price
	ft	\$/ft
- .5 Unit Price 05 – Additional Electrical Cable Install.:
 

.1 Unit Price shall be the combined Supply and Install (S&I) Unit Price for each foot of new electrical cable, a price shall be provided for each gauge of wire used for the job.	Measurement Unit	S & I Unit Price
	ft	\$/ft
- .6 Unit Price 06 – Commissioning Tech.:
 

.1 Unit Price shall be the per hour rate for an individual specializing in commissioning.	Measurement Unit	S & I Unit Price
	hour	\$/hr
- .7 Unit Price 07 – Commissioning Tech.:

		Measurement Unit	S & I Unit Price
.1	Unit Price shall be the per hour rate for an individual specializing in controls programming.	hour	\$/hr

**END OF SECTION**

## 1.01 DEFINITIONS

- .1 Alternative Price: A price for a substitution which is an addition or a deduction from the Base Bid Price. It may be required by the Owner or offered by the Bidder for selection at the discretion of the Owner. The Work defined in an Alternative Price is not included in the Base Bid Price.
- .2 Separate Price: A price for Work that shall be added to the Base Bid Price if selected by the Owner. The Work defined in a Separate Price is not included in the Base Bid Price.
- .3 Itemized Price: A price for Work that is included in the Base Bid Price but is required to be itemized for information only (e.g. accounting, funding, costing). The Work defined in an Itemized Price shall not be deducted from the Base Bid Price.

## 1.02 GENERAL

- .1 Acceptance of Alternatives is at the sole discretion of the Owner.
- .2 Submit complete and accurate prices for each Alternative, including overhead and profit, labour and materials.
- .3 Include in each Alternative costs by Work of Subcontractors whose Work is affected, including costs for modifications to their Work as may be required should the Alternative be accepted.
- .4 Claims for extras to the Contract because of the acceptance of an Alternative will not be accepted.

## 1.03 ALTERNATIVE PRICES

- .1 Alternate prices are as follows:
  - .1 Alternate Price No 01: Leisure Pool Flocculant Deduction.
    - .1 Alternate: Provide a deduction in the Contract price for the Leisure Pool representing the complete exclusion of the flocculant system work, including all associated demolition, removal, and disposal of existing equipment, as well as omission of all new supply and installation, including all equipment, piping, controls, electrical connections, supports, and any related installation requirements; the deduction shall represent the full credit to the Contract for the omission of this work, inclusive of all labour, materials, overhead, and profit.
  - .2 Alternate Price No 02: Competition Pool Flocculant Deduction
    - .1 Alternate: Provide a deduction in the Contract price for the Competition Pool representing the complete exclusion of the flocculant system work, including all associated demolition, removal, and disposal of existing equipment, as well as omission of all new supply and installation, including all equipment, piping, controls, electrical connections, supports, and any related installation requirements; the deduction shall represent the full credit to the Contract for the omission of this work, inclusive of all labour, materials, overhead, and profit.
  - .3 Alternate Price No 03: Tot Pool Flocculant Deduction.
    - .1 Alternate: Provide a deduction in the Contract price for the Tot Pool representing the complete exclusion of the flocculant system work, including all associated demolition, removal, and disposal of existing equipment, as well as omission of all new supply and installation, including all equipment, piping, controls, electrical connections, supports, and any

related installation requirements; the deduction shall represent the full credit to the Contract for the omission of this work, inclusive of all labour, materials, overhead, and profit.

.4 Alternate Price No 04: Hot Tub Flocculant Deduction.

- .1 Alternate: Provide a deduction in the Contract price for the Hot Tub representing the complete exclusion of the flocculant system work, including all associated demolition, removal, and disposal of existing equipment, as well as omission of all new supply and installation, including all equipment, piping, controls, electrical connections, supports, and any related installation requirements; the deduction shall represent the full credit to the Contract for the omission of this work, inclusive of all labour, materials, overhead, and profit.

**1.04 SEPARATE PRICES**

- .1 [Not required.]

**1.05 ITEMIZED PRICES**

.1 Itemized Price No. 1: Mobilization and Demobilization

- .1 Includes all mobilization, site setup, temporary facilities, protection measures, access equipment, and final demobilization required to complete the work. Price shall include all labour, materials, equipment, and incidentals required to complete the respective scope of work in full.

.2 Itemized Price No. 2: Leisure Pool System

- .1 Includes demolition of the existing leisure pool chemical treatment systems, flocculant system, and all associated piping and appurtenances. Work further includes the supply and installation of new leisure chemical treatment, and flocculation systems, and all associated piping, valving, and connections, including tie-ins to existing systems and equipment. Price shall include all labour, materials, equipment, and incidentals required to complete the respective scope of work in full.

.3 Itemized Price No. 3: Competition Pool System

- .1 Includes demolition of the existing competition pool chemical treatment systems, flocculant system, and all associated piping and appurtenances. Work further includes the supply and installation of new competition pool chemical treatment systems, flocculant system, and all associated piping, valving, and connections, including tie-ins to existing systems and equipment. Price shall include all labour, materials, equipment, and incidentals required to complete the respective scope of work in full.

.4 Itemized Price No. 4: Tot Pool System

- .1 Includes demolition of the existing tot pool chemical systems, flocculant system, and all associated piping and appurtenances. Work further includes the supply and installation of new tot pool chemical treatment, and flocculant system, and all associated piping, valving, and connections. Price shall include all labour, materials, equipment, and incidentals required to complete the respective scope of work in full.

.5 Itemized Price No. 5: Hot Tub System

- .1 Includes demolition of the existing hot tub chemical systems, flocculant system, and all associated piping and appurtenances. Work further includes the supply and installation of new hot tub chemical treatment, and flocculant system, and all associated piping, valving, and connections. Price shall include all labour,

materials, equipment, and incidentals required to complete the respective scope of work in full.

- .6 Itemized Price No. 6: Testing and Commissioning
  - .1 Includes pressure testing of piping systems, flushing, startup, commissioning of chemical systems, and functional verification to demonstrate proper operation. Price shall include all labour, materials, equipment, and incidentals required to complete the respective scope of work in full.
- .7 Itemized Price No. 7: Contractor Supplied Pool Chemicals
  - .1 Includes the provision and supply of initial pool chemicals required for startup and commissioning, including but not limited to calcium hypochlorite and sodium bisulfate, as required to achieve initial water balance and operational conditions. Price shall include all labour, materials, handling, delivery, and incidentals required to complete the respective scope of work in full.

**END OF SECTION**

## **1.01 SUMMARY**

- .1 Section Includes:
  - .1 Product/system substitution requests after award of Contract (after bids have closed).

## **1.02 DEFINITIONS**

- .1 In this Section "Substitution" means a Product, a manufacturer, or both, not originally specified in Contract Documents by proprietary name but proposed for use by Contractor in place of a Product, a manufacturer, or both, specified by proprietary name.

## **1.03 SUBSTITUTION PROCEDURES**

- .1 Contractor may propose a Substitution wherever a Product or manufacturer is specified by proprietary name(s), unless there is accompanying language indicating that Substitutions will not be considered.
- .2 Only Substitution requests from the Contractor will be considered. Requests from Subcontractors or suppliers will not be accepted.
- .3 Submit proposed substitutions on the "Product Substitution Request Form" appended to this Section, refer to article 1.05.
- .4 Contractor may propose a Substitution wherever a Product or manufacturer is specified by proprietary name(s) and accompanied by language such as "or equal", "or approved equal", or other similar words. Do not construe such language as an invitation to unilaterally provide a Substitution without Consultant's prior acceptance in writing. Do not order or install any Substitution without a Supplemental Instruction or Change Order.
- .5 Provided a proposed Substitution submission includes all of the information specified in this Section under Submission Requirements for Proposed Substitutions; Consultant will promptly review and accept or reject the proposed Substitution.
- .6 If Contractor fails to order a specified Product or order a Product by a specified manufacturer in adequate time to meet Contractor's construction schedule, Consultant will not consider that a valid reason to accept a Substitution.
- .7 If Consultant accepts a Substitution and subject to Owner's agreement, the change in the Work will be documented in the form of either a Supplemental Instruction or Change Order as specified in Section 01 26 00 – Contract Modification Procedures.
- .8 If a Substitution is accepted in the form of a Supplemental Instruction or Change Order, Contractor shall not revert to an originally specified Product or manufacturer without Consultant's prior written acceptance.
- .9 Substitutions will not be considered when they are indicated or implied on Shop Drawings or product data submittals without separate written request, or when acceptance will require revision to the Contract Documents.

## **1.04 SUBMISSION REQUIREMENTS FOR PROPOSED SUBSTITUTIONS**

- .1 Submit one digital copy in PDF format, of each request for Substitution. Limit each request to one proposed Substitution.
- .2 Include with each proposed Substitution the following information:
  - .1 Identification of the Substitution, including product name and manufacturer's name, address, telephone numbers, and web site.

- .2 Reason(s) for proposing the Substitution.
  - .3 A statement verifying that the Substitution will not affect the Contract Price and Contract Time or, if applicable, the amount and extent of a proposed increase or decrease in Contract Price and Contract Time on account of the Substitution.
  - .4 A statement verifying that the Substitution will not affect the performance or warranty of other parts of the Work.
  - .5 Manufacturer's Product literature for the Substitution, including shop drawings, material descriptions, compliance with applicable codes and reference standards, performance and test data, compatibility with contiguous materials and systems, and environmental considerations.
  - .6 Product samples as applicable.
  - .7 A summarized comparison of the physical properties and performance characteristics of the specified Product and the Substitution, with any significant variations clearly highlighted.
  - .8 Availability of maintenance services and sources of replacement materials and parts for the Substitution, as applicable, including associated costs and time frames.
  - .9 If applicable, estimated life cycle cost savings resulting from the Substitution.
  - .10 Details of other projects and applications where the Substitution has been used
  - .11 Identification of any consequential changes in the Work to accommodate the Substitution and any consequential effects on the performance of the Work as a whole. A later claim for an increase to the Contract Price or Contract Time for other changes in the Work attributable to the Substitution will not be considered.
- .3 A request constitutes a representation that the Contractor:
- .1 Has investigated proposed Product and determined that it meets or exceeds the quality level of the specified Product.
  - .2 Will provide the same warranty for the Substitution as for the specified Product.
  - .3 Will coordinate installation and make changes to other Work which may be required for the Work to be complete with no additional cost to Owner.
  - .4 Waives claims for additional costs or time extension which may subsequently become apparent.
  - .5 Will reimburse Owner and Consultant for review or redesign services associated with re-approval by authorities.

**1.05 FORMS**

- .1 Submit requests for substitutions after Contract award on "Product Substitution Request Form" appended to this Section.
- .2 Requests submitted without the form will not be considered.

**END OF SECTION**

**PRODUCT SUBSTITUTION REQUEST FORM**

(Refer to Section 01 25 00 - PRODUCT SUBSTITUTION PROCEDURES)

**APPLICANT:**

**PROJECT:**

ADDRESS: \_\_\_\_\_  
 \_\_\_\_\_  
 \_\_\_\_\_  
 \_\_\_\_\_

SUBMITTED BY: \_\_\_\_\_

E-MAIL ADDRESS: \_\_\_\_\_

FAX NO.: \_\_\_\_\_

TELEPHONE NO.: \_\_\_\_\_

SUBMITTAL DATE: \_\_\_\_\_

LOCATION: Kenora, Ontario

TENDER CLOSING DATE: \_\_\_\_\_

List below items being offered. Give manufacturers Name, Model, Catalogue number, Type, etc. Detailed description and Specifications to be attached as "Supporting Data"	Contract Specification No.	Reference Section	List below items shown in the contract specifications.  One reference for each item.	Consultant	
	(Indicate Contract Drawing No. if applicable)			"A" Accepted	"R" Rejected

**CONTRACTOR TO COMPLETE SPACE BELOW**

(Refer to Section 01 25 00 - PRODUCT SUBSTITUTION PROCEDURES)

Savings to Owner for accepting Substitution: No  Yes  ADD [DEDUCT] \$ \_\_\_\_\_

Proposed Substitution changes to Contract Time: No  Yes  ADD [DEDUCT] \_\_\_\_\_ Days

**REVIEWER:**

Date Request Received: \_\_\_\_\_

Date Reviewed: \_\_\_\_\_

Review Endorsed By: \_\_\_\_\_

REVIEWER'S COMMENTS: (in case of rejection or of cost or time implication)

\_\_\_\_\_  
 \_\_\_\_\_  
 \_\_\_\_\_  
 \_\_\_\_\_

### **1.01 METHOD OF CONTRACT PRICE ADJUSTMENT - CHANGE ORDERS**

- .1 Unless otherwise agreed, the adjustment of the Contract Price on account of a proposed change in the Work shall be based on a quotation for a fixed price increase or decrease to the Contract Price regardless of the Contractor's actual expenditures and savings.

### **1.02 CHANGE ORDER PROCEDURES**

- .1 Upon issuance by the Consultant to the Contractor of a proposed change in the Work, and unless otherwise requested in the proposed change or unless otherwise agreed:
  - .1 Submit to the Consultant a fixed price quotation for the proposed change in the Work within five Working Days after receipt of the proposed change in the Work.
  - .2 If requested in the proposed change, provide a detailed breakdown of the price quotation including the following to the extent applicable, with appropriate supporting documentation:
    - .1 Estimated labour costs, including hours and applicable hourly rates based on the accepted schedule of labour rates.
    - .2 Estimated Product costs, including Supplier quotations, estimated quantities and unit prices.
    - .3 Estimated Construction Equipment costs.
    - .4 Enumeration of all other estimated costs included in the price quotation.
    - .5 Estimated credit amounts for labour and Products not required on account of the proposed change.
    - .6 Fees, not exceeding the applicable percentages for overhead and profit as specified in this Section.
    - .7 Where applicable, Subcontractor quotations, also including a detailed breakdown of all the above.
  - .3 Include in the quotation the increase or decrease to the Contract Time, if any, for the proposed change, stated in number of Working Days.
  - .4 Include in the quotation the number of Working Days for which the quotation is valid.
  - .5 The quotation will be evaluated by the Consultant and the Owner and, if accepted by the Owner, be documented in the form of a signed Change Order.

### **1.03 FEES FOR OVERHEAD AND PROFIT - CHANGE ORDERS**

- .1 Where the Contractor's price quotation for a Change Order result in a net increase to the Contract Price, the Contractor's entitlement to a fee for overhead and profit in the quotation shall be as follows, as applicable:
  - .1 Mark-Ups: Costs for increases in the Contract Price shall be marked up to a maximum as follows for overhead and profit (overhead and profit shall include office costs, estimating, IT costs, clean-up, as-builts, safety, additional supervision costs, coordination, and costs for additional insurance, taxes, bonding and permits):
    - .1 Contractor: 10% overhead and 5% fee on the cost of his own Work, and 5% overhead and 5% fee on Subcontractors' prices.
    - .2 Subcontractors: 10% overhead and 5% fee on the cost of their own Work.
  - .2 Decreases: Credits for decreases in the Contract Price may not be marked up.
  - .3 Substantiation: For all changes, the Contractor shall submit details of quantities, prices and fees as outlined above, together with substantiating documentation.

- .4 Time for Submission and Acceptance of Quotation: The Contractor will cooperate in the pricing of the change to submit his quotation within ten Working Days of the Consultant's request, and the quotation shall remain open for acceptance for 21 Working Days from the date of submission.
- .5 Value Added Taxes (HST) shall not be considered a cost to the Contract. Therefore overhead and profit shall not be applied to Value Added Taxes. Quotations for changes to the Contract Price shall not indicate any amount for Value Added Taxes. Value Added Taxes shall be shown as a separate line item on Progress Payments only

#### **1.04 METHOD OF CONTRACT PRICE ADJUSTMENT - CHANGE DIRECTIVES**

- .1 Unless the Owner and the Contractor reach an earlier agreement on the adjustment to the Contract Price by means of a Change Order that cancels the Change Directive, the adjustment in the Contract Price for change carried out by way of a Change Directive shall be determined as specified in the General Conditions of Contract after the change in the Work is completed.

#### **1.05 CHANGE DIRECTIVE PROCEDURES**

- .1 If a Change Directive is issued for a change in the Work for which a proposed change was previously issued, but no Change Order has yet been signed, the Change Directive shall cancel the proposed change and any Contractor quotations related to that change in the Work.
- .2 When proceeding with a change in the Work under a Change Directive, keep accurate records of daily time sheets for labour and Construction Equipment, and invoices for Product and Construction Equipment costs. Submit such records to the Consultant weekly, until the Change Order superseding the Change Directive is issued.

#### **1.6 FEES FOR OVERHEAD AND PROFIT - CHANGE DIRECTIVES**

- .1 The Contractor's entitlement to a fee for overhead and profit on the Contractor's expenditures and savings attributable to a Change Directive shall be as follows, as applicable:
  - .1 For work performed by the Contractor's own forces, 10% of the Contractor's net increase in costs.
  - .2 For work performed by a Subcontractor, 5% of the sum of the Subcontractor's net increase in costs plus the Subcontractor's fee.
- .2 A Subcontractor's entitlement to a fee for overhead and profit on the Subcontractor's expenditures and savings attributable to a Change Directive shall be as follows, as applicable:
  - .1 For work performed by the Subcontractor's own forces, 10% of the Subcontractor's net increase in costs.
- .3 Where a Change Directive results in net savings on account of work not required to be performed and a net decrease in the Contractor's or Subcontractor's cost, the net savings to the Contractor or Subcontractor shall be calculated without any adjustment for fees for overhead and profit.
- .4 When a Change Directive is ultimately recorded as a Change Order, there shall be no additional entitlement to fees for overhead and profit beyond those specified in this article.

**1.7 SUPPLEMENTAL INSTRUCTIONS**

- .1 The Consultant may issue Supplemental Instructions to provide clarifications to the Contract Documents, provide additional information, or make minor variations in the Work not involving adjustment in the Contract Price or Contract Time.
- .2 If the Contractor considers a Supplemental Instruction to require an adjustment in Contract Price or Contract Time, the Contractor shall promptly notify the Consultant and the Owner in writing and shall not proceed with any work related to the Supplemental Instruction pending receipt of a Change Order, a Change Directive, or, in accordance with the dispute resolution provisions of the General Conditions of Contract, a Notice in Writing of a dispute and instructions to proceed.

**END OF SECTION**

## **1.01 REQUESTS FOR INFORMATION**

- .1 General: Immediately upon discovery of the need for interpretation of the Contract Documents, prepare and submit a Request for Information (RFI) to the Consultant in the form specified in this Section.
  - .1 Coordinate and submit RFIs in a prompt manner so as to avoid delays in the Work.
  - .2 Keep each RFI to one specific item only. Do not combine several items requiring interpretation into one RFI.
  - .3 For RFIs submitted by email include project name, RFI reference number and RFI subject in the email subject.
- .2 Consultant will only consider RFIs submitted by the prime Contractor. Consultant will not accept, review, or reply to RFIs submitted by Subcontractors, suppliers or other entities under Contract with the Contractor.
- .3 Content of the RFI: Include a detailed, legible description of item needing interpretation and include the following:
  - .1 Project name
  - .2 Project number
  - .3 Date
  - .4 Name of Contractor.
  - .5 Name of Consultant.
  - .6 RFI reference number, numbered sequentially starting with "001".
  - .7 A subject line that briefly describes the RFI.
  - .8 Full description of the item requiring interpretation.
  - .9 References to specification Section number and title, including related Articles and Paragraphs, as appropriate.
  - .10 Reference drawing number and details, as appropriate.
  - .11 Field dimensions and conditions, as appropriate.
  - .12 Contractor's suggested resolution. If Contractor's suggested resolution impacts the Contract Time or the Contract Price, state the impact in the RFI.
  - .13 Contractor's signature or the signature of his designated representative.
  - .14 Attachments:
    - .1 Include detail drawings, sketches, descriptions, measurements, photos, Product Data, Shop Drawings, coordination drawings, and other information necessary to describe items requiring interpretation.
    - .2 Include dimensions, thicknesses, structural grid references, and details of affected materials, assemblies, and attachments on attached drawings and sketches.

## **1.02 RFI SUBMITTAL FORM**

- .1 Provide own RFI submittal form, acceptable to Consultant, and include all content specified in this Section.
- .2 Submit RFI form and attachments as electronic files in Adobe Acrobat PDF format.

**1.03 NUISANCE OR REDUNDANT RFI**

- .1 Consultant will not respond to nor reply to the following Contractor-generated nuisance or redundant RFI's.
  - .1 Requests for approval of submittals.
  - .2 Requests for approval of substitutions.
  - .3 Requests for approval of Contractor's means and methods.
  - .4 Requests for approval of corrective actions for deficient Work.
  - .5 Requests for coordination information already indicated in the Contract Documents.
  - .6 Requests for adjustments in the Contract Time or the Contract Price.
  - .7 Requests for interpretation of Consultant's response on submittals.
  - .8 Incomplete or inaccurately prepared RFIs.
- .2 Do not list nuisance and redundant RFI's in the RFI log.

**1.04 CONSULTANT'S RESPONSE**

- .1 Consultant will review each RFI, determine action (or no action) required, and submit his/her reply back to the Contractor.
- .2 Allow ten working days for Consultant's response time for each RFI. RFI's that are received by the Consultant after 13:00 hrs on Working Days will be considered as have been received on the next Working Day.
- .3 Consultant's failure to reply to any RFI within the time period specified above or within a reasonable time period, as determined by the Consultant, will not be considered a reason for a delay claim by the Contractor.
- .4 The Consultant may extend the response time for any RFI at his/her discretion. Reasons may include, but not necessarily be limited to, the following:
  - .1 Too many RFIs submitted on the same day or within a short time period.
  - .2 RFI's which require extensive review and research by the Consultant, which may include requests for additional information from other sources, the timing of which the Consultant has no control.
  - .3 RFIs which, in the Consultant's opinion, will have no significant impact on the construction progress schedule and therefore may be deferred for a reasonable period of time.
- .5 Consultant's action may include a request for additional information, in which case Consultant's response time will be re-adjusted to the date when the additional information is received by the Consultant.
- .6 If Contractor believes the Consultant's RFI response warrants a change in the Contract Time or the Contract Price, notify the Consultant in writing within ten days of receipt of the Consultant's RFI response.

**1.05 CONTRACTOR'S RESPONSE**

- .1 On receipt of Consultant's response to an RFI:
  - .1 Update RFI log as specified herein.
  - .2 Review response and, submit a reply to the Consultant, within ten working days of receipt of Consultant response, stating whether the Consultant's response is either acceptable or not acceptable.
- .2 If Consultant's response is acceptable:
  - .1 Distribute the response to affected parties and proceed accordingly.

- .3 If Consultant's response is considered not acceptable:
  - .1 Resubmit the RFI and include reason(s) for disagreement.
  - .2 Consultant will review and submit a reply to the Contractor within ten Working Days of receipt of resubmittal, notwithstanding the Consultants extension of response time as specified in this Section.

**1.06 REQUESTS FOR INTERPRETATION (RFI) LOG**

- .1 Prepare, maintain, and submit a tabular log of RFIs organized by the RFI reference number.
- .2 Submit RFI log with project meeting minutes.
- .3 Include the Following:
  - .1 Project name
  - .2 Name and address of Contractor.
  - .3 Name and address of Consultant.
  - .4 RFI reference number including RFIs that were returned without action or withdrawn.
  - .5 RFI description/subject.
  - .6 Date the RFI was submitted.
  - .7 Date Consultant's response was received.
  - .8 Date Consultant requested additional information.
  - .9 Date RFI was closed.

**END OF SECTION**

**1.01 SCHEDULE OF VALUES**

- .1 Refer to GC 5.2 "Application for Payment" in CCDC 2 - 2020.
- .2 Submit at least 15 calendar days prior to the first application for payment an initial schedule of values for Consultant's review. Modify the initial schedule of values if and as requested by Consultant. Obtain Consultant's written acceptance of the initial schedule of values prior to the first application for payment.
- .3 Together with the first and all subsequent applications for payment, submit updated versions of the schedule of values to indicate the values, to the date of application for payment, of work performed and Products delivered to Place of the Work.
- .4 Provide the schedule of values in an electronic spreadsheet format based on the format provided and content described in latest edition of CCDC 24 - A Guide to Model Forms and Support Documents.

**1.02 CASH FLOW PROJECTION**

- .1 Prior to the first application for payment submit, for Consultant's review, a forecast of approximate monthly progress payments for each month of the Contract Time.
- .2 Submit revised cash flow forecasts when required due to significant changes in rate of progress of the Work or significant changes in the Contract Price.

**1.03 WORKERS' COMPENSATION CLEARANCE**

- .1 Submit proof of workers' compensation clearance with each application for payment.

**1.04 PAYMENT FOR PRODUCTS STORED OFF SITE**

- .1 Owner may, due to extraordinary circumstances and at Owner's sole discretion, make payments for Products delivered to and stored at a location other than Place of the Work, subject to:
  - .1 a request submitted by Contractor in writing, with appropriate justification, and
  - .2 whatever conditions Owner or Consultant may establish for such payments, as required to protect Owner's interests.

**1.05 RELEASE OF HOLDBACK**

- .1 Refer to GC 5.4 "Substantial Performance of the Work and Payment of Holdback" in CCDC 2 - 2020.

**END OF SECTION**

**1.01 SUMMARY**

- .1 Section Includes:
  - .1 Start-up meeting, progress meetings and reports.

**1.02 MEETING LOCATION**

- .1 The Owner will provide a room within the existing building for Construction Progress Meetings. Meetings may be held virtually at the Owner's discretion.

**1.03 CONSTRUCTION START-UP MEETING**

- .1 Promptly after Contract award, Consultant will establish the time and location of a construction start-up meeting to review and discuss administrative procedures and responsibilities. Consultant will notify Contractor at least five Working Days before the meeting.
- .2 Senior representatives of the Owner, Consultant, Contractor, and major Subcontractors are to attend.
- .3 Consultant will chair Start-Up Meeting, record minutes, and distribute minutes to all attending parties within four (4) working days after meeting.
- .4 Suggested Agenda:
  - .1 Appointment of official representative of Owner, Contractor, Subcontractors, Consultant, and subconsultants in the Work.
  - .2 Preconstruction photographs.
  - .3 Project communications.
  - .4 Contract Documents for construction purposes.
  - .5 Documents at the site.
  - .6 Contractor's use of premises.
  - .7 Work restrictions.
  - .8 Cash allowances.
  - .9 Substitution procedures.
  - .10 Contract modification procedures.
  - .11 Request for information (RFI) procedures.
  - .12 Payment procedures.
  - .13 Construction progress meetings.
  - .14 Construction progress schedule: in accordance with Section 01 32 16.13 - Construction Progress Schedule - Bar (GANTT) Chart.
  - .15 Submittals schedule and procedures.
  - .16 Deliveries.
  - .17 Procedures for changes, field decisions, change orders, approvals required, mark-up percentages permitted, time extensions, overtime, and administrative requirements.
  - .18 Quality requirements, including testing and inspection procedures.
  - .19 Construction facilities.
  - .20 Temporary barriers and enclosures.
  - .21 Site safety.
  - .22 Site security.

- .23 Cleaning and waste management.
- .24 Record drawings in accordance with Section 01 78 00 - Closeout Submittals.
- .25 Operation and Maintenance manuals in accordance with Section 01 78 00 - Closeout Submittals.
- .26 Take-over procedures, acceptance, warranties.
- .27 Monthly progress claims, administrative procedures, photographs, holdbacks.
- .28 Appointment of inspection and testing agencies or firms in accordance with Section 01 40 00 - Quality Requirements.
- .29 Insurances and transcript of policies.

**1.04 CONSTRUCTION PROGRESS MEETINGS**

- .1 Schedule regular bi-weekly construction progress meetings for the duration of the Work. Contractor shall prepare meeting agendas, chair the meetings, and record and distribute the minutes.
- .2 Location: as agreed to between Owner and Contractor.
- .3 Contractor shall record in the meeting minutes significant decisions and identify action items and action dates by attendees or the parties they represent.
- .4 Contractor shall distribute copies of minutes within three (3) Working Days after each meeting to meeting attendees and any affected parties who may not be in attendance.
- .5 Ensure that Subcontractors attend as and when appropriate to the progress of the Work.
- .6 Notify parties minimum five (5) days prior to meetings.
- .7 Agenda for each meeting shall include the following, as a minimum:
  - .1 Review and approval of minutes of previous meeting.
  - .2 Review of Work progress since previous meeting.
  - .3 Field observations, including any problems, conflicts, or concerns.
  - .4 Problems which impede construction schedule.
  - .5 Review of off-site fabrication delivery schedules.
  - .6 Corrective measures and procedures to regain projected schedule.
  - .7 Revision to construction schedule and comparison to initial Gantt-Chart Schedule.
  - .8 Review schedule progress, during succeeding work period and comparison to initial Gantt-Chart Schedule.
  - .9 Review of submittal schedule; expedite as required.
  - .10 Proposed changes in the Work.
  - .11 Review of proposed changes for effect on construction schedule and completion date.
  - .12 Requests for information.
  - .13 Site safety issues.
  - .14 Other business.

**END OF SECTION**

## 1.01 SUMMARY

- .1 Section Includes:
  - .1 Administrative and procedural requirements for documenting the progress of construction during performance of the Work, including the following:
    - .1 Master Plan.
    - .2 Contractor's Project Schedule.
    - .3 Project Schedule updating reports.

## 1.02 DEFINITIONS

- .1 Activity: Element of Work performed during course of Project. Activity normally has expected duration and expected cost and expected resource requirements. Activities can be subdivided into tasks.
- .2 Bar (Gantt) Chart: Graphic display of schedule-related information. In typical bar chart, activities or other Project elements are listed down left side of chart, dates are shown across top, and activity durations are shown as date-placed horizontal bars. Generally, Bar Chart should be derived from commercially available computerized project management system.
- .3 Baseline: Original approved plan (for Project, Work package, or activity), plus or minus approved scope changes.
- .4 Construction Work Week: Monday to Friday, inclusive, will provide five-day work week and define schedule calendar working days as part of Bar (Gantt) Chart submission.
- .5 Duration: Number of work periods (not including holidays or other nonworking periods) required to complete activity or other project element. Usually expressed as Work Days or work weeks.
- .6 Master Plan: Summary level schedule that identifies major activities and key milestones.
- .7 Milestone: Significant event in project, usually completion of major deliverable.
- .8 Project Schedule: Planned dates for performing activities and the planned dates for meeting milestones. Dynamic, detailed record of tasks or activities that must be accomplished to satisfy Project objectives. Monitoring and control process involves using Project Schedule in executing and controlling activities and is used as basis for decision making throughout project life cycle. Formatted as a Bar (Gantt) Chart.
- .9 Ready-for-Takeover: As defined in CCDC 2-2020.
- .10 Substantial Completion: As defined in lien legislation applicable to the Place of the Work

## 1.03 REQUIREMENTS

- .1 Ensure Master Plan and Project Schedule are practical and remain within specified Contract duration.
- .2 Plan to complete Work in accordance with prescribed milestones and time frame.
- .3 Limit activity durations to maximum of approximately ten Working Days, to allow for progress reporting.

## 1.04 ACTION AND INFORMATIONAL SUBMITTALS

- .1 Provide submittals in accordance with Section 01 33 00 - Submittal Procedures.

- .2 Submit to Consultant within ten Working Days of award of Contract Master Plan formatted as a Bar (Gantt) Chart for review of planning, monitoring and reporting of project progress.
- .3 Submit Project Schedule for Consultant's review within ten working days of receipt of acceptance of Master Plan.
- .4 Resubmit finalized Project Schedule to Consultant within five working days after return of reviewed copy.

**1.05 PROJECT MILESTONES**

- .1 As stipulated in Section 01 11 00 - Summary of Work.

**1.06 MASTER PLAN**

- .1 Develop horizontal, Gantt-chart-type construction schedule.
- .2 Consultant will review and return revised schedules within ten working days.
- .3 Revise impractical schedule and resubmit within ten working days.
- .4 Accepted revised schedule will become the Master Plan and be used as a baseline for updates.

**1.07 CONTRACTOR'S PROJECT SCHEDULE: GENERAL**

- .1 Develop detailed Project Schedule derived from the Master Plan.
- .2 Ensure detailed Project Schedule includes as minimum milestone and activity types as follows:
  - .1 Award
  - .2 Shop Drawings and Samples
  - .3 Permits
  - .4 Mobilization
  - .5 Heating, Ventilating, and Air Conditioning
  - .6 Electrical
  - .7 Testing
  - .8 Demobilization

**1.08 PROJECT SCHEDULE REPORTING**

- .1 Update Project Schedule on a monthly basis reflecting activity changes and completions, as well as activities in progress.
- .2 Include as part of Project Schedule, narrative report identifying Work status to date, comparing current progress to baseline, presenting current forecasts, defining problem areas, anticipated delays and impact with possible mitigation.

**1.09 PROJECT MEETINGS**

- .1 Discuss Project Schedule at regular site meetings, identify activities that are behind schedule and provide measures to regain slippage. Activities considered behind schedule are those with projected start or completion dates later than current approved dates shown on baseline schedule.
- .2 Weather related delays with their remedial measures will be discussed and negotiated.

**END OF SECTION**

## **1.01 SUMMARY**

- .1 Section Includes:
  - .1 Shop Drawings
  - .2 Product data, test reports, certificates.
  - .3 Manufacturer's instructions and field reports

## **1.02 DEFINITIONS**

- .1 Action Submittals: Written and graphic information and physical samples that require Consultant's responsive action. Submittals may be rejected for not complying with requirements. Unless specifically noted otherwise in individual Sections, the following are considered "action submittals":
  - .1 Product Data
  - .2 Shop Drawings
  - .3 Test and inspection reports
  - .4 Master Plan and Project Schedule
  - .5 Closeout submittals
- .2 Informational Submittals: Written and graphic information and physical samples that do not require Consultant's responsive action. Submittals may be rejected for not complying with requirements. Unless specifically noted otherwise in individual Sections, the following are considered "informational submittals":
  - .1 Certificates
  - .2 Maintenance data
  - .3 Manufacturer's instructions
  - .4 Permits
  - .5 Product warranties
  - .6 Photographic documentation
  - .7 Schedule of tests and inspections
  - .8 Safety data sheets (SDS)
  - .9 Testing agency qualifications

## **1.03 ADMINISTRATIVE**

- .1 Submit specified submittals to Consultant for review. Submit promptly and in orderly sequence so as to not cause delay in the Work. Failure to submit in ample time is not considered sufficient reason for an extension of Contract Time or for Product substitutions or other deviations from the Drawings and Specifications.
- .2 Where required by authorities having jurisdiction, provide submittals to such authorities for review and approval.
- .3 Do not proceed with Work affected by a submittal until review is complete.
- .4 Present Shop Drawings, Product data, and samples in imperial units. Where items or information is not produced in imperial units, converted values are acceptable.
- .5 Review submittals, provide verified field measurements where applicable, and affix Contractor's review stamp prior to submission to Consultant. Contractor's review stamp represents that necessary requirements have been determined and verified, and that the

submittal has been checked and coordinated with requirements of the Work and Contract Documents. Submittals not stamped, signed, dated, and identified as to specific project will be returned without being examined and considered rejected.

- .6 Notify Consultant, in writing at time of submission, identifying deviations from requirements of Contract Documents stating reasons for deviations.
- .7 Verify field measurements and that affected adjacent work is coordinated.
- .8 Submittals not meeting specified requirements will be returned with comments.
- .9 Contractor's responsibility for errors and omissions in submission is not relieved by Consultant's review of submittals.
- .10 Contractor's responsibility for deviations in submission from requirements of Contract Documents is not relieved by the Consultant review.
- .11 Keep one reviewed copy of each submission on site.
- .12 Reproduction of construction Drawings to serve as background for Shop Drawings is not permitted.
- .13 Do not propose Substitutions or deviations from Contract Documents via Shop Drawing, Product data and sample submittals.
- .14 Processing Time: Allow time for submittal review, including time for resubmittals, as follows. Time for review shall commence on Consultant's receipt of submittal. No extension of the Contract Time will be authorized because of failure to transmit submittals enough in advance of the Work to permit processing, including resubmittals.
  - .1 Submittals that are received by the Consultant after 13:00 hrs on Working Days will be considered as have been received on the next Working Day.
  - .2 Initial Review: Allow ten Working Days for initial review of each submittal. Allow additional time if coordination with subsequent submittals is required. Consultant will advise Contractor when a submittal being processed must be delayed for coordination.
  - .3 Intermediate Review: If intermediate submittal is necessary, process it in same manner as initial submittal.
  - .4 Resubmittal Review: Allow ten Working Days for review of each resubmittal.

#### **1.05 SHOP DRAWINGS AND PRODUCT DATA**

- .1 Refer to General Condition GC 3.8.
- .2 Submit one electronic copy of Shop Drawings where specified in the technical Specifications.
- .3 Submit one electronic copy of Product data sheets or brochures where specified in the technical Specifications.
- .4 Electronic Submittals: Prepare submittals as PDF package, incorporating complete information into each PDF file. Name PDF file with submittal number.
- .5 Indicate Products, methods of construction, and attachment or anchorage, erection diagrams, connections, explanatory notes and other information necessary for completion of the Work.
- .6 Where Products attach or connect to other Products, indicate that such items have been coordinated, regardless of Section under which adjacent items will be supplied and installed. Indicate cross-references to Drawings, Specifications and other already reviewed Shop Drawings.
- .7 Accompany submittals with a transmittal information including:

- .1 Date.
- .2 Project title and number.
- .3 Contractor's name and address.
- .4 Identification of each submittal item and quantity.
- .5 Other pertinent data.
- .8 Shop Drawing submittals shall include:
  - .1 Date and revision dates.
  - .2 Project title and number.
  - .3 Name and address of:
    - .1 Subcontractor.
    - .2 Supplier.
    - .3 Manufacturer.
  - .4 Contractor's stamp, date, and signature of Contractor's authorized representative responsible for Shop Drawing review, indicating that each Shop Drawing has been reviewed for compliance with Contract Documents and, where applicable, that field measurements have been verified.
  - .5 Delegated design professional's stamp, date and signature where specifically requested in the specifications
  - .6 Details of appropriate portions of the Work as applicable:
    - .1 Fabrication.
    - .2 Layout, showing dimensions, including identified field dimensions, and clearances.
    - .3 Setting or erection details.
    - .4 Capacities.
    - .5 Performance characteristics.
    - .6 Standards.
    - .7 Operating weight.
    - .8 Wiring diagrams.
    - .9 Single line and schematic diagrams.
    - .10 Relationships to other parts of the Work.
- .9 Product data submittals shall include safety data sheets (SDS) for all controlled Products.
- .10 Where a submittal includes information not applicable to the Work, clearly identify applicable information and strike out non-applicable information.
- .11 Supplement standard information to include details applicable to Project.
- .12 If upon Consultant's review no errors or omissions are discovered, or if only minor corrections are required as indicated, submittal will be returned and fabrication or installation of Work may proceed.
- .13 If upon Consultant's review significant errors or omissions are discovered, a so noted copy will be returned for correction and resubmission. Do not commence fabrication or installation.
- .14 Consultant's review of submittal(s) is for general conformance related to the Consultant's scope of work for the component's indicated and does not mean that the Consultant has verified or approves the submittal(s). The Contractor remains solely responsible for the submittal(s) and this review by the Consultant does not relieve the Contractor of the Contractor's responsibility for errors or omissions in the submittal(s) or for meeting all

requirements of the Contract Documents. This review does not mean that the Consultant approves the detailed design inherent in the submittal, responsibility for which shall remain with the Contractor submitting same, nor does this review mean that the Consultant accepts any deviation of the submittal(s) from the Contract Documents. The Contractor is responsible for confirming all dimensions and correlating them at the Place of Work, for all construction means, methods and techniques, and for coordination of construction work of all trades, including coordination of all submittals.

- .15 Resubmit corrected submittals through same procedure indicated above, before any fabrication or installation of the Work proceeds. When resubmitting, notify Consultant in writing of any revisions other than those requested by Consultant.

#### **1.06 SAMPLES**

- .1 Submit samples for Consultant's review where specified in the technical Specifications and as the Consultant may request.
- .2 Label samples as to identify material, manufacturer, make/model number, origin, and intended use in the Work.
- .3 Deliver samples prepaid to Consultant's business address or as directed.
- .4 Notify Consultant in writing, at the time of submission, of any deviations in samples from requirements of Contract Documents.
- .5 Consultant selection from samples is not intended to change the Contract Price or Contract Time. If a selection would affect the Contract Price or Contract Time, notify Consultant in writing prior to proceeding with the Work.
- .6 Resubmit samples as required by Consultant to comply with Contract Documents.
- .7 Reviewed and accepted samples will establish the standard against which installed Work will be reviewed.

#### **1.07 CERTIFICATES AND TRANSCRIPTS**

- .1 Submit transcription of insurance immediately after award of Contract.

#### **1.08 PHOTOGRAPHIC DOCUMENTATION**

- .1 Submit electronic copy of colour digital photography in .jpg format, standard resolution monthly with progress statement.
- .2 Project identification: Name and number of project and date of exposure indicated.
- .3 Number of Viewpoints: Four locations.
- .1 Viewpoints and their locations confirmed by Consultant.
- .4 Frequency of Photographic Documentation: Minimum monthly and as follows:
- .1 Provide photographs of existing building to record existing conditions prior to start of construction work.
- .2 Upon completion of services before concealment, and as directed by Consultant.

**END OF SECTION**

## **1.01 SUMMARY**

- .1 Section Includes:
  - .1 Requirements and limitations for cutting and patching during demolition Work.
  - .2 Selective demolition and removal of existing materials, equipment and finishes; cutting openings in walls, ceiling, floors and roof decks as required to accommodate the new work and finishes.
  - .3 Patching and making good existing work and finishes affected by alteration and renovation work.
  - .4 Salvage of existing materials and equipment where indicated.

## **1.02 RELATED REQUIREMENTS**

- .1 Patching and making good existing construction and finishes as part of the work of the respective Subcontractors whose work is affected.
- .2 Removal, relocation, of existing mechanical and/or electrical services and equipment.

## **1.03 GENERAL PROCEDURES**

- .1 The existing building is to remain occupied and functional during the work of this project. Execute work with least possible interference or disturbance to building operations, occupants, the general public, and the normal use of the premises.
- .2 Prior to start of any alteration work, arrange with the Owner and Consultant a work schedule satisfactory to operational requirements of the existing facility.
- .3 The Owner shall vacate only those areas designated for alteration work.
- .4 Confine construction activities to designated work areas. Do not store materials, tools or equipment outside of designated work areas.
- .5 Prevent migration of dust and debris into occupied areas.
- .6 Establish access routes to and from the work areas. Use only designated access routes for movement of workers, tools, equipment, materials, and construction debris.
- .7 Where work must proceed in occupied areas, clean up at the end of each workday. Place tools, equipment, and materials into secure lock-up.
- .8 Provide temporary protection to cut and partially finished surfaces to building occupants and general public from possible injury.
- .9 Maintain existing services to building and provide for personnel and vehicle access.
- .10 Where security is reduced by the Work provide temporary means to maintain security, if requested by the Owner.

## **1.04 NOISY WORK RESTRICTIONS IN OCCUPIED FACILITIES**

- .1 Noisy work may be completed during operational hours which are Monday to Friday from 7:00 hrs to 21:00 hrs.
- .2 Allow for hours of Work restrictions in construction progress schedule.
- .3 Use powder actuated devices only with Consultant's and Owner's written permission.

**1.05 MAINTAINING LIFE SAFETY SYSTEMS IN OCCUPIED FACILITIES**

- .1 Maintain operational life safety systems and public access to exits in occupied areas during all stages of the Work.
- .2 Determine nature and exact locations of existing fire and smoke sensors prior to the commencement of the Work. Avoid direct or indirect jarring while working in adjacent areas and exercise caution to avoid triggering these devices.
- .3 Be responsible for costs incurred by Owner on account of false fire alarms activated as a result of the execution of the Work without adequate precautions.

**1.06 EXISTING SERVICES**

- .1 Notify, Owner, Consultant, and utility companies of intended interruption of services and obtain required permission.
- .2 Where Work involves breaking into or connecting to existing services or utilities, give Consultant and Owner 48 hours notice for necessary interruption of mechanical or electrical service throughout course of work. Minimize duration of interruptions. Carry out work at times as directed by governing authorities with minimum disturbance to pedestrian, and vehicular traffic.
- .3 Establish location and extent of service lines in area of work before starting Work. Notify Consultant of findings.
- .4 Submit schedule to and obtain approval from Owner and Consultant for any shut-down or closure of active service or facility including power and communications services. Adhere to approved schedule and provide notice to affected parties.
- .5 Provide temporary services when directed by Consultant to maintain critical building and tenant systems.
- .6 Where unknown services are encountered, immediately advise Consultant and confirm findings in writing.
- .7 Protect, relocate or maintain existing active services. When inactive services are encountered, cap off in manner approved by authorities having jurisdiction.
- .8 Record locations of maintained, re-routed and abandoned service lines.
- .9 Construct barriers in accordance with Section 01 56 00 - Temporary Barriers and Enclosures.

**1.07 WASTE MANAGEMENT AND DISPOSAL**

- .1 Comply with Section 01 74 00 - Cleaning and Waste Management, supplemented as follows.
- .2 Except for items indicated for salvage, construction waste, abandoned or demolished materials and equipment are the Contractor's responsibility and shall be promptly removed from site.
- .3 Dispose of construction debris, abandoned equipment and materials off site via designated access routes.
- .4 Do not allow demolition debris to accumulate within the building or on site. Remove debris on a regular basis.
- .5 Do not allow waste and debris to block access routes to and from exits, fire lanes, or impede access to the building.
- .6 Do not burn rubbish or debris on site.

- .7 Do not use Owner's waste containers for waste removal.
- .8 Provide suitable waste containers. Locate large waste containers on Owner's property only in areas acceptable to the Owner.

**1.08 TEMPORARY ENCLOSURES**

- .1 Comply with Section 01 56 00 - Temporary Barriers and Enclosures, supplemented as follows.
- .2 Construct temporary enclosures to isolate work areas from occupied areas of the building(s). Erect barriers to contain construction debris and prevent unauthorized entry to work areas.
- .3 Prior to erection confirm exact location(s) with Consultant.
- .4 Where temporary barriers restrict access to emergency exits review security requirements with Consultant prior to erection.
- .5 Provide continuous dust barrier of 0.0254 mm (6 mil) polyethylene sheet. Seal holes and joints to prevent migration of dust to occupied areas.

**1.9 PROTECTIVE COVERS**

- .1 Where furniture, furnishings, cabinet work or other finished work is adjacent to or in areas where alteration work is in progress provide covers to protect against construction debris and dust.
- .2 Remove covers and clean up after each work stage as instructed by Consultant.

**1.10 EXISTING MECHANICAL AND ELECTRICAL SERVICES**

- .1 Prior to start of Work identify and confirm the location of all mechanical and electrical services within or passing through construction areas. Confirm their origin and destination.
- .2 Where services are concealed within walls, floors, or ceilings and cannot be visually identified use electronic scanning devices or other acceptable means to locate and identify concealed services.
- .3 Do not shut off, disconnect, or remove existing mechanical and electrical services without prior notification of Consultant.
- .4 Where existing service must be shut-down or disconnected, notify Owner in advance of shut-down or disconnection. Provide schedule indicating which services are affected and duration of shut-down.
- .5 Some services within construction areas may serve other areas of the building not affected by construction work and must remain in service during construction period. Take special precautions to protect and maintain continuance of services that are to remain active to service adjacent areas.
- .6 Include for required connections, temporary or permanent, for continuance of existing services.

**1.11 LOOSE FURNISHINGS**

- .1 Owner will remove and relocate loose furnishings and portable equipment such as desks, chairs, telephones and other portable items within work areas.

**1.12 SALVAGE MATERIAL**

- .1 Remove as salvage items as indicated.
- .2 Remove items carefully to prevent damage. Dismantle large items to fit through openings and ease of transport.

- .3 For items indicated for reinstallation store on site until required.

### **1.13 EQUIPMENT**

- .1 Provide equipment, tools and machinery for proper execution of the Work.

### **1.14 PREPARATION**

- .1 Structural and load-bearing elements:
  - .1 Obtain Consultant's written approval before cutting, boring or sleeving structural or load-bearing members including roof decks, floor assemblies or load bearing walls and columns.
  - .2 Electronically scan structural elements to confirm location of structural steel and reinforcing before starting work. Record locations on record drawings.
  - .3 Mark out exact locations and dimensions prior to inspection.
  - .4 Do not proceed with the work until the Consultant has reviewed and confirmed proposed work.
- .2 Prevent movement, settlement or damage of structures, services, and parts of existing building to remain.
  - .1 Repair damage caused by demolition as directed by Consultant.
- .3 Support affected structures and, if safety of the structure being demolished or adjacent structures or services appear to be endangered, take preventative measures, stop Work and immediately notify Consultant.

### **1.15 SELECTIVE DEMOLITION FOR ALTERATION WORK**

- .1 Specialists familiar with the materials affected shall perform selective demolition work.
- .2 Perform in a manner to neither damage nor endanger any part of the existing building or work in progress.
- .3 Demolition work indicated on drawings is schematic only. Verify all dimensions and conditions on site.
- .4 Do not damage or deface existing construction, equipment or finishes indicated to remain or items indicated for salvage.
- .5 Marking:
  - .1 Each Subcontractor is responsible for marking out locations of all cutting, boring, and demolition required for installation of their respective work.
  - .2 Extra costs for additional cutting and patching required because of errors in marking out of locations of cutting and demolition work shall be paid by the Subcontractor responsible for the error in marking.
- .6 Cutting:
  - .1 Keep cutting to no more than 10% larger than outside dimensions of item penetrating another material.
  - .2 Use concrete saw for cutting concrete and masonry.
  - .3 Use diamond core drill for cutting small diameter openings in concrete and masonry
  - .4 Make cuts with clean, true, smooth edges to minimize patchwork and to provide suitable surface for integration of new materials.
- .7 Openings:

- .1 Cut openings in walls, partitions, ceilings, roofs, floors as required for installation of new work.
- .2 Coordinate with Mechanical, Electrical and other Subcontractors.
- .3 Contractor is responsible for cutting openings larger than 150 by 150 mm (6 by 6 inches) or 150 mm (6 inches) in diameter. Openings smaller than these shall be the responsibility of the Subcontractor requiring the opening.
- .8 Partitions:
  - .1 Remove or cut openings in interior partitions to accommodate new work.
  - .2 In areas with concrete toppings or terrazzo flooring remove masonry partitions completely down to structural slabs. Do not cut off at topping line. Clean out resulting channel to expose base slab.

**1.16 PATCHING AND MAKING GOOD**

- .1 Patching and making good of existing materials and finishes is the responsibility of the Subcontractor whose work is affected.
- .2 Patch and make good all damage to existing materials and finishes resulting from work of this Contract.
- .3 Patching, unless otherwise noted, shall match existing adjacent surfaces in all respects. Make patchwork inconspicuous in final assembly.
- .4 Patch and repair to standard of construction of surrounding materials, except where indicated otherwise.
- .5 Fit work airtight to pipes, sleeves, ducts, conduit and other penetrations. Seal all penetrations tight with acceptable materials.
- .6 Patch openings, holes, cuts and around pipes, ductwork, conduit and other work passing through fire separations and fire rated assemblies. Use materials and methods to maintain integrity of fire ratings. Use materials meeting Underwriters' Laboratories Canada (ULC) requirements and authorities having jurisdiction.

**END OF SECTION**

## **1.01 SUMMARY**

- .1 Section Includes:
  - .1 Health and safety requirements and adherence.

## **1.02 REFERENCE STANDARDS**

- .1 Government of Canada
  - .1 Canadian Construction Safety Code, 1997
  - .2 Canada Labour Code, R.S.C., 1985, c. L-2, Part II, Occupational Health and Safety
  - .3 Workplace Hazardous Materials Information System 2022 (WHMIS)
- .2 National Research Council
  - .1 National Building Code of Canada 2020 (NBCC)
  - .2 National Fire Code of Canada 2020 (NFCC)
- .3 Province of Ontario
  - .1 Ontario Building Code 2024 (OBC)
  - .2 The Workers Safety and Insurance Act, 1997 (WSIA)

## **1.03 ADMINISTRATIVE REQUIREMENTS**

- .1 Coordination:
  - .1 Review and coordinate hot work safety requirements as indicated in other Sections.

## **1.04 REGULATORY REQUIREMENTS**

- .1 Observe and enforce construction safety measures with construction safety measures of the following:
  - .1 Canadian Construction Safety Code.
  - .2 Canada Labour Code, Part II, Occupational Health and Safety.
  - .3 NBC, Part 8 Safety Measures at Construction and Demolition Sites.
  - .4 NFC, Sections 5.2., and 5.6.
  - .5 (ON) The Workers Safety and Insurance Act, 1997 (WSIA).
  - .6 Municipal statutes, and authorities having jurisdiction.
- .2 In event of conflict between any provisions of above authorities, the more stringent requirements to apply.

## **1.05 RESPONSIBILITY**

- .1 Refer to CCDC GC 9.4 Construction Safety.
- .2 The "Prime Contractor" according to applicable jurisdiction, is responsible for health and safety of persons on site, safety of property on site and for protection of persons adjacent to site and environment to extent that they may be affected by conduct of Work.
- .3 Comply with and enforce compliance by employees with safety requirements of Contract Documents, applicable federal, provincial, territorial and local statutes, regulations, and ordinances, and with site-specific health and safety plan, and fire safety plan.

**1.06 HEALTH AND SAFETY PLAN**

- .1 Develop written site-specific health and safety plan, and fire safety plan, based on hazard assessment prior to commencing any site Work and continue to implement, maintain, and enforce plan until final demobilization from site.
  - .1 Pool may be drained at time of work.
- .2 Consultant may respond in writing, where deficiencies or concerns are noted and may request re-submission with correction of deficiencies or concerns.

**1.07 FIRE SAFETY**

- .1 Fire Safety Plan:
  - .1 Develop written Fire Safety Plan in accordance with the NFCC, Section 5.6.1.3 specific to the area of work.
  - .2 A copy of the approved Fire Safety Plan to be posted and maintained on site, the Contractor to ensure that all persons accessing the site are briefed on, and adhere to, the requirements of the Fire Safety Plan.
- .2 Hot Works
  - .1 Conform to requirements of NFCC, Section 5.2. Hot Works, Section 5.6. Construction and Demolition Sites, and as follows.
  - .2 Hot works including, cutting, grinding, torch work, and welding:
    - .1 Make application for a hot works permit.
    - .2 If possible, hot works shall be performed in a safe area, absent of combustibles. If not possible, remove combustibles from the area of hot works.
    - .3 Provide and maintain at least one portable fire extinguisher in the hot work area.
    - .4 Ventilate area of hot work by use of approved portable supply and exhaust fans.
    - .5 Ventilate hot works in enclosed spaces in accordance with Section 01 51 00 - Temporary Utilities.
    - .6 Provide a continuous fire watch during the hot work and for a period of not less than one hour after its completion and four hours after completion of the work.
- .3 Burning rubbish and construction waste materials is not permitted on site.

**1.08 ACTION AND INFORMATIONAL SUBMITTALS**

- .1 Provide submittals in accordance with Section 01 33 00 - Submittal Procedures.
- .2 Informational Submittals:
  - .1 Provide a valid certificate of recognition (COR) as issued by the provincial construction safety association or other certifying organization authorized the province.
  - .2 Submit Contractor's site-specific safety plan and fire safety plan at least five Business Days prior to the commencement of any Work on the Site.
  - .3 Submit two copies of Contractor's authorized representative's work site health and safety inspection reports to Consultant.
  - .4 Submit copies of incident and accident reports.

**1.9 WORK SITE SAFETY**

- .1 Comply with and enforce the construction health and safety measures required by provincial legislation applicable to the Place of the Work, and applicable provisions of Federal, and municipal safety laws and ordinances.
- .2 Assume full responsibility for the safety and organization of the Work until Final Certificate of Payment.
- .3 Follow any directives from the Workplace Safety and Insurance Board (WSIB) and provide any safeguards required.
- .4 Post all necessary danger signs.
- .5 Maintain on site five sets of CSA approved construction safety hats, safety vests and safety glasses for use of authorized visitors to site. Visitors are responsible for their own CSA approved footwear.

**1.10 EXISTING SITE CONDITIONS**

- .1 Hazardous Materials: Hazardous Material Assessment for the Work area is currently being performed and the information from that report will be shared when available via addendum.

**1.11 UNFORESEEN HAZARDS**

- .1 Should any unforeseen or peculiar safety-related factor, hazard, or condition become evident during performance of Work, follow procedures in place for employee's right to refuse work in accordance with Acts and Regulations of the Province of Ontario. Advise Consultant verbally and in writing.

**1.12 CERTIFICATE OF RECOGNITION (COR) PROGRAM**

- .1 Contractor to possess valid Certificate of Recognition (COR™) for an accredited occupational health and safety program applicable to the Place of the Work.
- .2 Subcontractors with employees doing construction work on this site must show safety program registration verified by either the Heavy Construction Association or the Construction Safety Association as applicable to the Place of the Work.

**1.13 OVERLOADING**

- .1 Do not load any part of the structure during the construction with a load greater than it is calculated to bear safely when complete. Ensure every temporary support is as strong as the permanent support. Do not place loads on concrete floors until they have obtained their permanent set.

**1.14 HAZARDOUS WORK**

- .1 Blasting or other use of explosives is not permitted.
- .2 Use powder actuated devices only after receipt of written permission from Consultant.

**1.15 SMOKING PRECAUTIONS**

- .1 Observe smoking regulations.

**END OF SECTION**

## 1.01 SUMMARY

- .1 Section Includes:
  - .1 Administrative and procedural requirements for quality assurance and quality control.
  - .2 Inspection and testing, administrative, and enforcement requirements.
    - .1 Testing and inspection services are required to verify compliance with requirements specified or indicated. These services do not relieve Contractor of responsibility for compliance with the Contract Document requirements.
      - .1 Specific quality-assurance and quality-control requirements for individual work results are specified in their respective specification sections. Requirements in individual sections may also cover production of standard products.
      - .2 Specified tests, inspections, and related actions do not limit Contractor's other quality-assurance and quality-control procedures that facilitate compliance with the Contract Document requirements.
      - .3 Requirements for Contractor to provide quality-assurance and quality-control services required by the Consultant, or authorities having jurisdiction are not limited by provisions of this section.
      - .4 Specific test and inspection requirements are not specified in this section.
      - .5 Inspection by Public Health Ontario before opening pool, contractor to contact public health one month prior to completion to ensure timely opening of the pool.
  - .3 Equipment/system adjust and balance.

## 1.02 RELATED REQUIREMENTS

- .1 Section 01 33 00 - Submittal Procedures: For submission of samples to confirm product quality.
- .2 Section 01 61 00 - Common Product Requirements: For material and workmanship quality, and reference standards.

## 1.03 DEFINITIONS

- .1 Experienced: When used with an entity or individual, "experienced" unless otherwise further described means having successfully completed a minimum of five previous projects similar in nature, size, and extent to this Project; being familiar with special requirements indicated; and having complied with requirements of authorities having jurisdiction.
- .2 Field Quality-Control Tests: Tests and inspections that are performed on-site for installation of the Work and for completed Work.
- .3 Installer/Applicator/Erector: Contractor or another entity engaged by Contractor as an employee, Subcontractor, or sub-subcontractor, to perform a particular construction operation, including installation, erection, application, assembly, and similar operations.
  - .1 Use of trade-specific terminology in referring to a trade or entity does not require that certain construction activities be performed by accredited or unionized individuals, or that requirements specified apply exclusively to specific trade(s).
- .4 Product Tests: Tests and inspections that are performed by a nationally recognized testing laboratory, or by a testing agency qualified to conduct product testing and acceptable to

authorities having jurisdiction, to establish product performance and compliance with specified requirements.

- .5 Quality-Control Services: Tests, inspections, procedures, and related actions during and after execution of the Work to evaluate those actual products incorporated into the Work and completed construction comply with requirements. Contractor's quality-control services do not include contract administration activities performed by the Consultant.
- .6 Quality-Assurance Services: Activities, actions, and procedures performed before and during execution of the Work to guard against defects and deficiencies and substantiate that proposed construction will comply with requirements.
- .7 Source Quality-Control Tests: Tests and inspections that are performed at the source; for example, plant, mill, factory, or shop.
- .8 Independent Inspection and Testing Agency: An entity engaged to perform specific tests, inspections, or both. Testing laboratory shall mean the same as testing agency.

#### **1.04 REFERENCE STANDARDS**

- .1 ASTM International
  - .1 ASTM E329, Standard Specification for Agencies Engaged in Construction Inspection, Testing, or Special Inspection

#### **1.05 CONFLICTING REQUIREMENTS**

- .1 Conflicting Standards and Other Requirements: If compliance with two or more standards or requirements are specified and the standards or requirements establish different or conflicting requirements for minimum quantities or quality levels, comply with the most stringent requirement. Refer conflicting requirements that are different, but apparently equal, to Consultant for direction before proceeding.
- .2 Minimum Quantity or Quality Levels: The quantity or quality level shown or specified shall be the minimum provided or performed. The actual installation may comply exactly with the minimum quantity or quality specified, or it may exceed the minimum within reasonable limits. To comply with these requirements, indicated numeric values are minimum or maximum, as appropriate, for the context of requirements. Refer uncertainties to by Consultant for a decision before proceeding.

#### **1.06 INFORMATIONAL SUBMITTALS**

- .1 Contractor's Quality-Control Plan: For quality-assurance and quality-control activities and responsibilities.
- .2 Qualification Data: For Contractor's quality-control personnel.
- .3 Testing Agency Qualifications: For testing agencies specified in "Quality Assurance" article to demonstrate their capabilities and experience. Include proof of qualifications in the form of a recent report on the inspection of the testing agency by a recognized authority.
- .4 Schedule of Tests and Inspections: Prepare in tabular form and include the following:
  - .1 Specification section number and title.
  - .2 Entity responsible for performing tests and inspections.
  - .3 Description of test and inspection.
  - .4 Identification of applicable standards.
  - .5 Identification of test and inspection methods.
  - .6 Number of tests and inspections required.

- .7 Time schedule or time span for tests and inspections.
- .8 Requirements for obtaining samples.
- .9 Unique characteristics of each quality-control service.
- .5 Reports: Prepare and submit certified written reports and documents as specified.
- .6 Permits, Licenses, and Certificates: For Consultant's record, submit copies of permits, licenses, certifications, inspection reports, releases, jurisdictional settlements, notices, receipts for fee payments, judgments, correspondence, records, and similar documents established for compliance with standards and regulations bearing on performance of the Work.

#### **1.07 CONTRACTOR'S QUALITY-CONTROL PLAN**

- .1 Quality-Control Plan, General: Submit quality-control plan within ten days of Notice of Award, and not less than five days prior to preconstruction conference. Submit in format acceptable to Consultant. Identify personnel, procedures, controls, instructions, tests, records, and forms to be used to carry out Contractor's quality-assurance and quality-control responsibilities. Coordinate with construction schedule.
- .2 Quality-Control Personnel Qualifications: Engage qualified personnel trained and experienced in managing and executing quality-assurance and quality-control procedures similar in nature and extent to those required for Project.
  - .1 Project quality-control manager may also serve as Project superintendent.
- .3 Submittal Procedure: Describe procedures for ensuring compliance with requirements through review and management of submittal process. Indicate qualifications of personnel responsible for submittal review.
- .4 Testing and Inspection: In quality-control plan, include a comprehensive schedule of Work requiring testing or inspection, including the following:
  - .1 Contractor-performed tests and inspections. Include required tests and inspections and Contractor-elected tests and inspections. Distinguish source quality-control tests and inspections from field quality-control tests and inspections.
  - .2 Contractor performed tests and inspections indicated in the Contract Documents, including tests and inspections indicated to be performed by the Building Envelope Commissioning Authority or an independent testing and inspection agency.
- .5 Continuous Inspection of Workmanship: Describe process for continuous inspection during construction to identify and correct deficiencies in workmanship in addition to testing and inspection specified. Indicate types of corrective actions to be required to bring work into compliance with standards of workmanship established by Contract requirements and approved mock-ups.
- .6 Monitoring and Documentation: Maintain testing and inspection reports including log of approved and rejected results. Include work Consultant have indicated as nonconforming or defective. Indicate corrective actions taken to bring nonconforming work into compliance with requirements. Comply with requirements of authorities having jurisdiction.

#### **1.08 REVIEW AND INSPECTION OF THE WORK**

- .1 Allow Consultant, or independent inspection and testing agencies access to Work. If part of Work is in preparation at locations other than Place of Work, allow access to such Work whenever it is in progress.
- .2 Give minimum 10 days notice for impending inspections if Work is designated for tests, inspections or approvals by Consultant.

- .3 If Contractor covers or permits to be covered Work that has been designated for tests, inspections or approvals before such is made, uncover such Work, have inspections or tests satisfactorily completed and make good such Work.
- .4 Consultant will order part of Work to be examined if Work is suspected to be not in accordance with Contract Documents. If, upon examination such work is found not in accordance with Contract Documents, correct such Work and pay cost of examination and correction. If such Work is found in accordance with Contract Documents, Owner shall pay cost of examination and replacement.
- .5 Test and Inspection Reports: Prepare and submit to the Consultant two copies of written reports specified in other sections. Include the following:
  - .1 Date of issue.
  - .2 Project title and number.
  - .3 Name, address, telephone number, and email address of testing agency.
  - .4 Dates and locations of samples and tests or inspections.
  - .5 Names of individuals making tests and inspections.
  - .6 Description of the Work and test and inspection method.
  - .7 Identification of product and Specification section.
  - .8 Complete test or inspection data.
  - .9 Test and inspection results and an interpretation of test results.
  - .10 Record of temperature and weather conditions at time of sample taking and testing and inspection.
  - .11 Comments or professional opinion on whether tested or inspected Work complies with the Contract Document requirements.
  - .12 Name and signature of laboratory inspector.
  - .13 Recommendations on retesting and reinspection.
- .6 Manufacturer's Technical Representative's Field Reports: Prepare written information documenting manufacturer's technical representative's tests and inspections specified in other sections. Include the following:
  - .1 Name, address, telephone number, and email address of technical representative making report.
  - .2 Statement on condition of substrates and their acceptability for installation of product.
  - .3 Statement that products at Project site comply with requirements.
  - .4 Summary of installation procedures being followed, whether they comply with requirements and, if not, what corrective action was taken.
  - .5 Results of operational and other tests and a statement of whether observed performance complies with requirements.
  - .6 Statement whether conditions, products, and installation will affect warranty.
  - .7 Other required items indicated in individual Specification sections.
- .7 Factory-Authorized Service Representative's Reports: Prepare written information documenting manufacturer's factory-authorized service representative's tests and inspections specified in other sections. Include the following:
  - .1 Name, address, telephone number, and email address of factory-authorized service representative making report.
  - .2 Statement that equipment complies with requirements.

- .3 Results of operational and other tests and a statement of whether observed performance complies with requirements.
- .4 Statement whether conditions, products, and installation will affect warranty.
- .5 Other required items indicated in individual Specification sections.
- .8 Provide copies to Contractor of work being inspected/tested and manufacturer/fabricator of material being inspected/tested.

**1.09 HOLD POINTS**

- .1 Define hold points as mandatory stages of the Work at which the Contractor shall not proceed without prior review and acceptance by the Consultant.
- .2 Identify all hold points within the Contractor's Quality-Control Plan and within the Schedule of Tests and Inspections. Clearly indicate the timing, location, and scope of each hold point in relation to the Work.
- .3 Provide minimum four Working Days notice to the Consultant prior to each hold point, in accordance with requirements for review and inspection of the Work.
- .4 Do not proceed with subsequent Work that would conceal or make inaccessible the portion of Work subject to a hold point until the required review has been completed and acceptance has been provided by the Consultant.
- .5 Where Work proceeds beyond a designated hold point without required review and acceptance, and at the direction of the Consultant, uncover and reinstate Work at no additional cost to the Owner.
- .6 Minimum hold points for this Project shall include, but are not limited to, the following:
  - .1 75% completion of installation: review of system installation, including equipment placement, piping, and major components, prior to completion of final connections.
  - .2 100% completion of installation: final review of complete installation prior to commissioning, start-up, or turnover activities.
- .7 Additional hold points may be identified in individual specification Sections or as required by the Consultant based on site conditions.

**1.10 QUALITY ASSURANCE**

- .1 Qualifications paragraphs in this article establish the minimum qualification levels required; individual Specification Sections specify additional requirements.
- .2 Manufacturer Qualifications: A firm experienced in manufacturing products or systems similar to those indicated for this Project and with a record of successful in-service performance, as well as sufficient production capacity to produce required units. As applicable, procure products from manufacturers able to meet qualification requirements, warranty requirements, and technical or factory-authorized service representative requirements.
- .3 Fabricator Qualifications: A firm experienced in producing products similar to those indicated for this Project and with a record of successful in-service performance, as well as sufficient production capacity to produce required units.
- .4 Installer Qualifications: A firm or individual experienced in installing, erecting, applying, or assembling work similar in material, design, and extent to that indicated for this Project, whose work has resulted in construction with a record of successful in-service performance.

- .5 Professional Engineer Qualifications: A professional engineer who is legally qualified to practice in jurisdiction where Project is located and who is experienced in providing engineering services of the kind indicated. Engineering services are defined as those performed for installations of the system, assembly, or product that is similar in material, design, and extent to those indicated for this Project.
- .6 Specialists: Certain Specification sections require that specific construction activities be performed by entities who are recognized experts in those operations. Specialists will satisfy qualification requirements indicated and engage in the activities indicated.
  - .1 Requirements of authorities having jurisdiction supersede requirements for specialists.
- .7 Testing and Inspecting Agency Qualifications: An independent agency with the experience and capability to conduct testing and inspection indicated, as documented in accordance with ASTM E329, and with additional qualifications specified in individual Sections; and, where required by authorities having jurisdiction, that is acceptable to authorities.
- .8 Manufacturer's Technical Representative Qualifications: An authorized representative of manufacturer who is trained and approved by manufacturer to observe and inspect installation of manufacturer's products that are similar in material, design, and extent to those indicated for this Project.
- .9 Factory-Authorized Service Representative Qualifications: An authorized representative of manufacturer who is trained and approved by manufacturer to inspect, demonstrate, repair, and perform service on installations of manufacturer's products that are similar in material, design, and extent to those indicated for this Project.

## 1.11 QUALITY CONTROL

- .1 Contractor Responsibilities: Where quality-control services are specified, the Contractor will engage a qualified testing agency to perform these services. Perform additional quality-control activities, whether specified or not, to verify and document that the Work complies with requirements.
  - .1 Contractor will furnish Consultant with names, addresses, and telephone numbers of testing agencies engaged and a description of types of testing and inspection they are engaged to perform.
  - .2 Payment for these services will be by Contractor.
  - .3 Costs for retesting and reinspecting construction that replaces or is necessitated by Work that failed to comply with the Contract Documents will be charged to Contractor, and the Contract Sum will be adjusted by Change Order.
  - .4 Unless otherwise indicated, provide quality-control services specified and those required by authorities having jurisdiction. Perform quality-control services required of Contractor by authorities having jurisdiction, whether specified or not.
  - .5 Engage a qualified testing agency to perform quality-control services.
  - .6 Notify testing agencies at least 24 hours in advance of time when Work that requires testing or inspection will be performed.
  - .7 Where quality-control services are indicated as Contractor's responsibility, submit a certified written report, in duplicate, of each quality-control service.
- .2 Retesting/Reinspecting: Regardless of whether original tests or inspections were Contractor's responsibility, provide quality-control services, including retesting and reinspecting, for construction that replaced Work that failed to comply with the Contract Documents.

- .3 Testing Agency Responsibilities: Cooperate with Consultant and Contractor in performance of duties. Provide qualified personnel to perform required tests and inspections.
  - .1 Notify Consultant and Contractor promptly of irregularities or deficiencies observed in the Work during performance of its services.
  - .2 Determine the locations from which test samples will be taken and in which in-situ tests are conducted.
  - .3 Conduct and interpret tests and inspections, and state in each report whether tested and inspected Work complies with or deviates from requirements.
  - .4 Submit a certified written report, in duplicate, of each test, inspection, and similar quality-control service through Contractor.
  - .5 Do not release, revoke, alter, or increase the Contract Document requirements or approve or accept any portion of the Work.
  - .6 Do not perform duties of Contractor.
- .4 Manufacturer's Field Services: Where indicated, engage a factory-authorized service representative to inspect field-assembled components and equipment installation, including service connections. Report results in writing as specified in Section 01 33 00 - Submittal Procedures.
- .5 Manufacturer's Technical Services: Where indicated, engage a manufacturer's technical representative to observe and inspect the Work. Manufacturer's technical representative's services include participation in preinstallation conferences, examination of substrates and conditions, verification of materials, observation of Installer activities, inspection of completed portions of the Work, and submittal of written reports.
- .6 Contractor's Associated Requirements and Services: Cooperate with agencies and representatives performing required tests, inspections, and similar quality-control services, and provide reasonable auxiliary services as requested. Notify agency sufficiently in advance of operations to permit assignment of personnel.
  - .1 Access to the Work.
  - .2 Incidental labor and facilities necessary to facilitate tests and inspections.
  - .3 Adequate quantities of representative samples of materials that require testing and inspection. Assist agency in obtaining samples.
  - .4 Facilities for storage and field curing of test samples.
  - .5 Delivery of samples to testing agencies.
  - .6 Preliminary design mix proposed for use for material mixes that require control by testing agency.
  - .7 Security and protection for samples and for testing and inspection equipment at Project site.
- .7 Coordination: Coordinate sequence of activities to accommodate required quality-assurance and quality-control services with a minimum of delay and to avoid necessity of removing and replacing construction to accommodate testing and inspection.
  - .1 Schedule times for tests, inspections, obtaining samples, and similar activities.
- .8 Schedule of Tests and Inspections: Prepare a schedule of tests, inspections, and similar quality-control services required by the Contract Documents. Coordinate and submit concurrently with Contractor's Construction Schedule. Update and submit with each Application for Payment.
  - .1 Schedule Contents: Include tests, inspections, and quality-control services, including Contractor- and Owner-retained services, commissioning activities, and other Project-required services paid for by other entities.

- .2 Distribution: Distribute schedule to Owner, Consultant, testing agencies, and each party involved in performance of portions of the Work where tests and inspections are required.

#### **1.12 INDEPENDENT INSPECTION AND TESTING AGENCIES**

- .1 Independent inspection and testing agencies will be engaged by the Contractor for the purpose of inspecting and/or testing portions of Work.
- .2 Retain and pay for inspection and testing that is for Contractor's own quality control or is required by regulatory requirements.
- .3 The testing requirements are specified under various sections of the Specifications. Test results to be submitted to the Consultant.
- .4 Costs for independent inspection and testing agencies to be paid by relevant party as indicated in various sections of the Specifications.
- .5 Provide equipment required for executing inspection and testing by the appointed agencies.
- .6 Employment of inspection and testing agencies by Contractor or Owner does not relieve Contractor from responsibility to perform the Work in accordance with Contract Documents.
- .7 Allow and arrange for inspection and testing agencies to have access to the Work, including access to off site manufacturing and fabrication plants.
- .8 If defects are revealed during inspection and testing, the appointed agency will request additional inspection and testing to ascertain full degree of defect. Correct defects and irregularities as advised by the Consultant at no cost to the Owner. Pay costs for retesting and re-inspection.

#### **1.13 INSPECTION AND TESTING AGENCY REPORTS**

- .1 For inspection and testing required by Contract Documents or by regulatory requirements, and performed by Contractor-retained inspection and testing agencies, submit electronic (PDF) copies of reports directly from the inspection and testing agency promptly to Consultant.
- .2 Provide copies to Subcontractor of work being inspected/tested and manufacturer/fabricator of material being inspected/tested.

#### **1.14 PROCEDURES**

- .1 Notify the appropriate agency and Consultant in advance of the requirement for inspection/tests, in order that attendance arrangements can be made.
- .2 Submit samples or materials required for testing as specifically requested in Specification Sections or as may be requested by Consultant. Submit with reasonable promptness and in an orderly sequence so as not to cause delay in the Work.
- .3 Provide labour and facilities to obtain and handle samples and materials on site. Provide sufficient space to store and cure test samples.

#### **1.15 DEFECTIVE WORK**

- .1 Refer to General Conditions GC2.4.
- .2 Remove defective Work, whether result of poor workmanship, use of defective products or damage and whether incorporated in Work or not, which has been rejected by Consultant as failing to conform to Contract Documents. Replace or re-execute in accordance with Contract Documents.

- .3 Make good other contractor's work damaged by such removals or replacements promptly.
- .4 If in opinion of Consultant it is not expedient to correct defective Work or Work not performed in accordance with Contract Documents, Owner will deduct from Contract Price difference in value between Work performed and that called for by Contract Documents, amount of which will be determined by Consultant.

#### **1.16 TEST AND INSPECTION LOG**

- .1 Coordinate requirements in "Test and Inspection Log" Paragraph below with requirements of authorities having jurisdiction.
- .2 Test and Inspection Log: Prepare a record of tests and inspections. Include the following:
  - .1 Date test or inspection was conducted.
  - .2 Description of the Work tested or inspected.
  - .3 Date test or inspection results were transmitted to the Consultant.
  - .4 Identification of testing agency or special inspector conducting test or inspection.
- .3 Maintain log at Project site. Post changes and revisions as they occur. Provide access to test and inspection log for the Consultant reference during normal working hours.
  - .1 Submit log at Project closeout as part of Project Record Documents.

#### **1.17 REPAIR AND PROTECTION**

- .1 General: On completion of testing, inspection, sample-taking, and similar services, repair damaged construction and restore substrates and finishes.
- .2 Provide materials and comply with installation requirements specified in other Specification Sections or matching existing substrates and finishes. Restore patched areas and extend restoration into adjoining areas with durable seams that are as invisible as possible. Comply with the Contract Document requirements for cutting and patching in Section 01 35 16 - Alteration Project Procedures.
- .3 Protect construction exposed by or for quality-control service activities.
- .4 Repair and protection are Contractor's responsibility, regardless of the assignment of responsibility for quality-control services.

#### **1.18 EQUIPMENT AND SYSTEMS**

- .1 Submit electronic (PDF) adjustment and balancing reports for mechanical and electrical systems to Consultant.

#### **1.19 Hold Points**

- .1

**END OF SECTION**

**1.01 SUMMARY**

- .1 Section Includes:
  - .1 Construction aids.
  - .2 Site office.
  - .3 Parking.

**1.02 REFERENCE STANDARDS**

- .1 Canadian Construction Documents Committee (CCDC)
  - .1 CCDC 2, Stipulated Price Contract, 2020.
- .2 Canadian Standards Association (CSA)
  - .1 CAN/CSA-Z321, Signs and Symbols for the Occupational Environment.

**1.03 CONSTRUCTION FACILITIES - GENERAL**

- .1 Provide temporary construction facilities as necessary for performance of the Work and in compliance with applicable regulatory requirements.
- .2 Maintain temporary construction facilities in good condition for the duration of the Work.
- .3 Remove temporary construction facilities from Place of the Work when no longer required.

**1.04 HOISTING**

- .1 Provide, operate and maintain hoists and cranes required for moving of workers, materials and equipment. Make financial arrangements with Subcontractors for use thereof.
- .2 Hoists and cranes shall be operated by qualified operator.

**1.05 ELEVATORS**

- .1 Use only elevators existing in building for moving workers and material.
  - .1 Protect walls of passenger elevators, to approval of Owner prior to use.
  - .2 Accept liability for damage, safety of equipment and overloading of existing equipment.
  - .3 Coordinate elevator schedule with Owner.

**1.06 SITE STORAGE/LOADING**

- .1 Confine Construction Equipment, Temporary Work, storage of Products, waste products and debris, and operations of employees and Subcontractors to limits indicated by laws, ordinances, permits, or the Contract Documents, do not unreasonably encumber the Place of the Work.
- .2 Do not load or permit to be loaded any part of the Work with a weight or force that will endanger the safety of the Work.

**1.7 CONSTRUCTION PARKING**

- .1 Limited parking will be permitted at the Place of the Work provided it does not disrupt continuing operation of the facility. Such use is limited to light duty trucks and equipment. Coordinate parking of Contractor vehicles with Owner and prepare alternative parking arrangements as required.
  - .1 Parking shall be permitted on the north side of the building near the boat launch.

**1.8 SITE OFFICE**

- .1 Office within building:
  - .1 When usable space is available within the project building and if approved by the Owner, the site office may be located within the building, utilizing rooms therein.
  - .2 Such areas may be used contingent upon there being no delay in completion of the work and there being no damages to material or finishes

**1.9 SANITARY FACILITIES**

- .1 Existing sanitary facilities within buildings may be used by construction workers. If use is permitted keep premises in clean and sanitary condition.
- .2 Keep sanitary facilities clean and fully stocked with the necessary supplies.

**1.10 CONSTRUCTION SIGNAGE**

- .1 Signs and notices for safety and instruction shall be in both official languages of Canada. Graphic symbols shall conform to internationally recognized symbols.
- .2 No other signs or advertisements, other than safety and warning signs, are permitted on site.
- .3 Maintain approved signs and notices in good condition for duration of project, and dispose of off site on completion of project or earlier if directed by Consultant.
- .4 General signage is not permitted anywhere on site except by specific written permission by the Owner.

**END OF SECTION**

**1.01 SUMMARY**

- .1 Section Includes:
  - .1 Barriers.
  - .2 Environmental Controls.

**1.02 BARRIERS AND ENCLOSURES - GENERAL**

- .1 Provide temporary barriers and enclosures necessary to protect the public and building occupants and to secure Place of the Work during performance of the Work.
- .2 Maintain temporary barriers and enclosures in good condition for the duration of the Work.
- .3 Remove temporary barriers and enclosures from Place of the Work when no longer required.
- .4 Confirm locations and installation with Consultant prior to installation.
- .5 Comply with applicable regulatory requirements.
- .6 Be responsible for damage incurred due to lack of or improper protection.

**1.03 WEATHER ENCLOSURES**

- .1 Provide weather tight enclosures to unfinished openings in floors and roofs.
- .2 Design weather enclosures to withstand wind pressure requirements.

**1.04 DUST TIGHT SCREENS**

- .1 General:
  - .1 Erect, maintain, and relocate screens as required to facilitate construction operations and *Owner's* operational requirements.
  - .2 Provide protection to ensure safe passage of people around selective demolition areas and to and from occupied portions of building.
  - .3 Do not close or obstruct exits, or other facilities used by occupants without written permission from authorities having jurisdiction.
  - .4 Provide temporary exiting requirements as indicated, and as required by authorities having jurisdiction.
- .2 Interior Hoarding Walls:
  - .1 Provide dust tight polyethylene screens to localize interior building areas from dust generating activities.
- .3 Maintain and relocate protection until such work is complete.
- .4 Confirm locations and installation with Consultant prior to installation.
- .5 Where screens restrict access to emergency exits review security requirements with Consultant prior to erection.
- .6 Erect, maintain, and relocate screens as required to facilitate construction operations and *Owner's* operational requirements.

**1.5 PROTECTION OF BUILDING FINISHES**

- .1 Provide necessary temporary barriers and enclosures to protect existing and completed or partially completed finished surfaces from damage during performance of the Work.

**END OF SECTION**

## 1.01 SUMMARY

- .1 Section Includes:
  - .1 Product quality, availability, storage, handling, protection, and transportation.
  - .2 Procedures for product substitution.
  - .3 Manufacturer's instructions.
  - .4 Quality of Work, coordination and fastenings.
  - .5 Prevention of dust and mould contamination of products and materials during delivery, storage and handling.

## 1.02 DEFINITIONS

- .1 Basis-of-Design Product Specification: A specification in which a single manufacturer's product is named and accompanied by the words "basis-of-design product," including make or model number or other designation. Published attributes and characteristics of basis-of-design product establish salient characteristics of products.
- .2 Comparable Product: Product by named manufacturer that is demonstrated and approved through the product substitution procedure process described in Article 1.05, to have the indicated qualities related to type, function, dimension, in-service performance, physical properties, appearance, and other characteristics that equal or exceed those of specified product.
- .3 Comparable Product Request Submittal: An action submittal requesting consideration of a comparable product, including the following information:
  - .1 Identification of basis-of-design product or fabrication or installation method to be replaced, including Specification Section number and title and Drawing numbers and titles.
  - .2 Data indicating compliance with the requirements specified in Part 2 "Comparable Products" Article.
- .4 Evaluation of Comparable Products: In addition to the basis-of-design product description, product attributes and characteristics may be listed to establish the significant qualities related to type, function, in-service performance and physical properties, weight, dimension, durability, visual characteristics, and other special features and requirements for purposes of evaluating comparable products of additional manufacturers named in the specification. Manufacturer's published attributes and characteristics of basis-of-design product also establish salient characteristics of products for purposes of evaluating comparable products.
- .5 New Products: Items that have not previously been incorporated into another project or facility. Salvaged items or items reused from other projects are not considered new products. Items that are manufactured or fabricated to include recycled content materials are considered new products, unless indicated otherwise.
- .6 Products: Items obtained for incorporating into the Work, whether purchased for Project or taken from previously purchased stock. The term "product" includes the terms "material," "equipment," "system," and terms of similar intent.
  - .1 Named Products: Items identified by manufacturer's product name, including make or model number or other designation shown or listed in manufacturer's published product literature that is current as of date of the Contract Documents.
- .7 Provide: Provide means to supply and install.

- .8 Subject to Compliance with Requirements: Where the phrase "Subject to compliance with requirements" introduces a product selection procedure in an individual Specification Section, provide products qualified under the specified product procedure. In the event that a named product or product by a named manufacturer does not meet the other requirements of the specifications, select another named product or product from another named manufacturer that does meet the requirements of the specifications; submit a comparable product request or substitution request, if applicable.
- .9 Substitution: Refer to Section 01 25 00 - Product Substitution Procedures for definition and limitations on substitutions.

### **1.03 REFERENCE STANDARDS**

- .1 Canadian Standards Association (CSA)
  - .1 CAN/CSA-Z317.13, Infection Control during Construction, Renovation, and Maintenance of Health Care Facilities.
- .2 Within text of each specifications section, reference may be made to reference standards. Conform to these reference standards, in whole or in part as specifically requested in specifications.
- .3 If there is question as to whether any product or system is in conformance with applicable standards, Consultant reserves right to have such products or systems tested to prove or disprove conformance.
- .4 Cost for such testing will be borne by Owner in event of conformance with Contract Documents or by Contractor in event of non-conformance.
- .5 Conform to latest date of issue of referenced standards in effect on date of submission of Bids, except where specific date or issue is specifically noted.
- .6 When material or equipment is specified by reference standard, prescriptive or performance specifications, upon request of Consultant, obtain from manufacturer an independent testing laboratory report, stating that material or equipment meets or exceeds specified requirements.

### **1.04 GENERAL**

- .1 Unless otherwise specified, maintain uniformity of manufacture for like items throughout.
- .2 Products, materials, equipment and articles (referred to as products throughout specifications) incorporated in Work shall be new, not damaged or defective, and of best quality (compatible with specifications) for purpose intended. If requested, furnish evidence as to type, source and quality of products provided.
- .3 Defective products, whenever identified prior to completion of Work, will be rejected, regardless of previous inspections. Inspection does not relieve responsibility, but is precaution against oversight or error. Remove and replace defective products at own expense and be responsible for delays and expenses caused by rejection.
- .4 Should any dispute arise as to quality or fitness of products, decision rests strictly with Consultant based upon requirements of Contract Documents.
- .5 Materials or products containing asbestos fibres or polychlorinated biphenyl's are not permitted on this project.

### **1.05 PRODUCT OPTIONS**

- .1 Subject to the provisions of Section 01 25 00 - Product Substitution Procedures:

- .1 Wherever a Product or manufacturer is specified by a single proprietary name, provide the named Product only.
- .2 Wherever more than one Product or manufacturer is specified by proprietary name for a single application, provide any one of the named Products.
- .2 Wherever a Product is specified by reference to a standard only, provide any Product that meets or exceeds the specified standard. If requested by Consultant, submit information verifying that the proposed Product meets or exceeds the specified standard.
- .3 Wherever a Product is specified by descriptive or performance requirements only, provide any Product that meets or exceeds the specified requirements. If requested by Consultant, submit information verifying that the proposed Product meets or exceeds the specified requirements.

**1.06 PRODUCT AVAILABILITY AND DELIVERY TIMES**

- .1 Promptly upon Contract award and periodically during construction, review and confirm Product availability and delivery times. Order Products in sufficient time to meet the construction progress schedule and the Contract Time.
- .2 If a specified Product is no longer available, promptly notify Consultant. Consultant will take action as required.
- .3 If delivery delays are foreseeable, for any reason, promptly notify Consultant.
  - .1 If a delivery delay is beyond *Contractor's* control, *Consultant* will provide direction.
  - .2 If a delivery delay is caused by something that was or is within *Contractor's* control, *Contractor* shall propose actions to maintain the construction progress schedule for *Consultant's* review and acceptance.
- .4 Immediately upon signing Contract, review product delivery requirements and anticipate foreseeable supply delays for any items. If delays in supply of materials, equipment or articles are foreseeable, notify Consultant of such in order that substitutions or other remedial action may be authorized in ample time to prevent delay in performance of Work.
- .5 In the event of failure to notify the Consultant at commencement of Work, and should it subsequently appear that Work may be delayed for such reason, the Consultant reserves the right to substitute more readily available products of similar character, at no increase in Contract Price or Contract Time.

**1.07 STORAGE, HANDLING, AND PROTECTION**

- .1 Store, handle, and protect Products during transportation to Place of the Work and before, during, and after installation in a manner to prevent damage, adulteration, deterioration and soiling.
- .2 Comply with manufacturer's instructions for storage, handling and protection.
- .3 Store packaged or bundled Products in original and undamaged condition with manufacturer's seals and labels intact. Do not remove from packaging or bundling until required in Work.
- .4 Comply with the requirements of the workplace hazardous materials information system (WHMIS) regarding use, handling, storage, and disposal of hazardous materials, including requirements for labeling and the provision of safety data sheets (SDS).
- .5 Store Products subject to damage from weather in weatherproof enclosures.
- .6 Store cementitious products clear of earth or concrete floors, and away from walls.

- .7 Keep sand, when used for grout or mortar materials, clean and dry. Store sand on wooden platforms and cover with waterproof tarpaulins during inclement weather.
- .8 Store sheet Products on flat, solid, supports and keep clear of ground. Slope to shed moisture.
- .9 Store and mix paints in heated and ventilated room. Remove oily rags and other combustible debris from site daily. Take every precaution necessary to prevent spontaneous combustion.
- .10 Touch-up damaged factory finished surfaces to Consultant's satisfaction. Use touch-up materials to match original.
- .11 Comply with CAN/CSA Z317.13 when shipping, handling and storing products susceptible to mould and dust contamination. Protect products from weather; take all precautions to prevent moisture or dust contamination.
  - .1 Wrap products in waterproof covers at plant or distribution centre prior to shipping.
  - .2 Load products in indoor facilities, and ship to project site in enclosed vehicles only. Do not use flat-bed trucks exposed to the elements.
  - .3 Unload products at project site only during dry weather.
  - .4 Store products indoors in dry location, off concrete floors.
  - .5 Products that become damp, wet or contaminated with mould, dust and dirt shall be designated as defective work in accordance with GC 2.4 – Defective Work and replaced at no additional cost to the Contract.
- .12 Remove and replace damaged Products at own expense and to the satisfaction of the Consultant.

#### **1.08 MANUFACTURERS' INSTRUCTIONS**

- .1 Unless otherwise indicated in the specifications, store, install or erect all products in accordance with manufacturer's recommendations. Do not rely on labels or enclosures that are provided with products. Obtain instructions directly from manufacturers.
- .2 Notify Consultant in writing of any conflicts between the Specifications and manufacturer's instructions so that the Consultant may establish the course of action to follow.
- .3 Notify Consultant, in writing, of conflicts between Contract Documents and manufacturer's instructions where, in Contractor's opinion, conformance with Contract Documents instead of the manufacturer's instructions may be detrimental to the Work or may jeopardize the manufacturer's warranty.
- .4 Provide manufacturer's representatives with access to the Work at all times. Render assistance and facilities for such access so that manufacturer's representatives may properly perform their responsibilities.
- .5 Improper installation or erection of products due to failure in complying with these requirements authorizes the Consultant to require any removal and re-installation that may be considered necessary, at no increases in Contract Price or Contract Time.

#### **1.09 QUALITY OF WORK**

- .1 Ensure Quality of Work is of highest standard, executed by workers experienced and skilled in respective duties for which they are employed. Immediately notify Consultant if required Work is such as to make it impractical to produce required results.
- .2 Do not employ anyone unskilled in their required duties. Consultant reserves right to require dismissal from site, workers deemed incompetent or careless.

- .3 Decisions as to standard or fitness of Quality of Work in cases of dispute rest solely with Consultant, whose decision is final.

#### **1.10 COORDINATION**

- .1 Ensure cooperation of workers in laying out Work. Maintain efficient and continuous supervision.
- .2 Ensure Work of various Subcontractors does not conflict or create interference.
- .3 Be responsible for the proper coordination and placement of openings, sleeves, and accessories.
- .4 Supply all items required to be built in as and when required, together with templates, measurements and shop drawings.
- .5 Ensure all workers examine the Drawings and Specifications covering the Work of others that may affect the performance of their own Work. Examine the Work of others and report to the Consultant, in writing, any defects, or deficiencies that may affect the Work. In the absence of any report, the Contractor shall be held to have waived all claims for damage to or defects in such Work.
- .6 Ensure that components requiring foundations or openings that are required for the installation of Work is coordinated. Furnish the necessary information to the Sections concerned in ample time to permit allowance for such items. Failure to comply with this requirement does not relieve the party at fault of the cost of cutting or drilling at a later date and subsequent patching.

#### **1.11 CONCEALMENT**

- .1 Conceal pipes, ducts, and wiring in floors, walls and ceilings in finished areas:
  - .1 after review by Consultant and authority having jurisdiction, and
  - .2 where locations differ from those shown on Drawings, after recording actual locations on as-built drawings.
- .2 Provide incidental furring or other enclosures as required.
  - .3 Provide suitable access doors, panels or plates to permit easy access to electrical access fittings (junction boxes, pull boxes, etc.), valves and equipment which requires periodic servicing as specified on the drawings.
- .4 Notify Consultant in writing of interferences before installation. Install as directed by Consultant.

#### **1.12 REMEDIAL WORK**

- .1 Refer to Section 01 35 16 - Alteration Project Procedures.
- .2 Perform remedial work required to repair or replace parts or portions of Work identified as defective or unacceptable. Coordinate adjacent affected Work as required.
- .3 Perform remedial work by specialists familiar with materials affected. Perform in a manner to neither damage nor put at risk any portion of Work.

#### **1.13 LOCATION OF FIXTURES**

- .1 Consider the location of fixtures, outlets and other mechanical and electrical items indicated on Drawings as approximate. The Consultant reserves the right to provide direction to move up to 1 800 mm (6 feet) from location shown without charge to Contract Price, provided notice is given to Contractor before related work has commenced.

- .2 Locate equipment fixtures and distribution systems to provide minimum interference and maximum usable space, and in accordance with manufacturer's recommendations for safety, access and maintenance.
- .3 Submit field drawings to indicate relative position of various services and equipment when required by Consultant.
- .4 Inform the Consultant of:
  - .1 Conflicting installation requirements. Install as directed.
  - .2 An impending installation. Install as directed.
- .5 Costs associated with relocation of mechanical and electrical devices resulting from failure to co-ordinate with Consultant prior to rough-in, are the responsibility of the Contractor.

#### **1.14 FASTENINGS**

- .1 Provide metal fastenings and accessories in same texture, colour, and finish as adjacent materials, unless otherwise indicated.
- .2 Prevent electrolytic action and corrosion between dissimilar metals and materials by using suitable non-metallic strips, washers, sleeves, or other permanent separators to avoid direct contact.
- .3 Use non-corrosive hot dip galvanized fasteners and anchors for securing exterior Work, unless stainless steel or other material is specifically requested in the affected Specification Section.
- .4 Space anchors within their load limit or shear capacity and ensure they provide positive permanent anchorage. Plugs of wood or any other organic material are not acceptable.
- .5 Keep exposed fastenings to a minimum, space evenly, and install neatly.
- .6 Fastenings which cause spalling or cracking of material to which anchorage is made are not acceptable.
- .7 Prior to installing structural anchors, hangers, or support systems, confirm proposed method and materials with Consultant.
- .8 When method of attachment, fastenings, or support system is unclear or not specified, submit written request for clarification to Consultant no later than 14 days prior to close of bids. Failure to submit request for clarification prior to stated deadline indicates Contractor shall provide safe and functional installation as specified in Contract Specifications and Drawings, and as directed by Consultant, at no additional cost to Contract. This Contract shall include all Work and costs involved to produce safe and functional installation for all equipment, fixtures and material specified, unless specifically indicated otherwise.
- .9 Unless specifically noted in Specifications or on Drawings, do not attach, fasten, or support pipes, ducts, conduit, wiring equipment or fixtures from or onto ceiling tiles, ceiling tile grid or ceiling tile grid supports.

#### **1.15 FASTENINGS - EQUIPMENT**

- .1 Use fastenings of standard commercial sizes and patterns with material and finish suitable for service.
- .2 Use heavy hexagon heads, semi-finished unless otherwise specified. Use No. 304 stainless steel for exterior areas.
- .3 Bolts may not project more than one diameter beyond nuts.
- .4 Use plain type washers on equipment, sheet metal and soft gasket lock type washers where vibrations occur. Use resilient washers with stainless steel.

**END OF SECTION**

## 1.01 SUMMARY

- .1 Section Includes:
  - .1 General administrative and procedural requirements governing execution of the Work including, but not limited to, the following:
    - .1 Installation of the Work.
    - .2 Starting and adjusting.
    - .3 Protection of completed Work and Work in progress.
  - .2 Except where otherwise specified in technical Specifications or otherwise indicated on Drawings, comply with requirements of this Section.

## 1.02 RELATED REQUIREMENTS:

- .1 Technical Specifications:
  - .1 Section 01 35 16 - Alteration Project Procedures: For demolition and removal of selected portions of the building and for cutting and patching penetrations in the construction.

## 1.03 EXAMINATION

- .1 Examination and Acceptance of Conditions: Before proceeding with each component of the Work, examine substrates, areas, and conditions, with Installer or Applicator present where indicated, for compliance with requirements for installation tolerances and other conditions affecting performance. Record observations.
  - .1 Examine roughing-in for mechanical and electrical systems to verify actual locations of connections before equipment and fixture installation.
  - .2 Examine walls, floors, and roofs for suitable conditions where products and systems are to be installed.
  - .3 Verify compatibility with and suitability of substrates, including compatibility with existing finishes or primers.
- .2 Written Report: Where a written report listing conditions detrimental to performance of the Work is required by other sections, include the following:
  - .1 Description of the Work.
  - .2 List of detrimental conditions, including substrates.
  - .3 List of unacceptable installation tolerances.
  - .4 Recommended corrections.
- .3 Proceed with installation only after unsatisfactory conditions have been corrected. Proceeding with the Work indicates acceptance of surfaces and conditions.

## 1.04 PREPARATION

- .1 Field Measurements: Take field measurements as required to fit the Work properly. Recheck measurements before installing each product. Where portions of the Work are indicated to fit to other construction, verify dimensions of other construction by field measurements before fabrication. Coordinate fabrication schedule with construction progress to avoid delaying the Work.
- .2 Space Requirements: Verify space requirements and dimensions of items shown diagrammatically on Drawings.

- .3 Review of Contract Documents and Field Conditions: Immediately on discovery of the need for clarification of the Contract Documents caused by differing field conditions outside the control of Contractor, submit a request for information to the Consultant according to requirements in Section 01 26 13 - Requests for Information.

#### **1.05 INSTALLATION**

- .1 General: Locate the Work and components of the Work accurately, in correct alignment and elevation, as indicated.
  - .1 Make vertical work plumb and make horizontal work level.
  - .2 Where space is limited, install components to maximize space available for maintenance and ease of removal for replacement.
  - .3 Conceal pipes, ducts, and wiring in finished areas unless otherwise indicated.
- .2 Comply with manufacturer's written instructions and recommendations for installing products in applications indicated.
- .3 Install products at the time and under conditions that will ensure the best possible results. Maintain conditions required for product performance until Substantial Completion.
- .4 Conduct construction operations so no part of the Work is subjected to damaging operations or loading more than that expected during normal conditions of occupancy.
- .5 Sequence the Work and allow adequate clearances to accommodate movement of construction items on site and placement in permanent locations.
- .6 Templates: Obtain and distribute to the parties' involved templates for work specified to be factory prepared and field installed. Check Shop Drawings of other portions of the Work to confirm that adequate provisions are made for locating and installing products to comply with indicated requirements.
- .7 Attachment: Provide blocking and attachment plates and anchors and fasteners of adequate size and number to securely anchor each component in place, accurately located and aligned with other portions of the Work. Where size and type of attachments are not indicated, verify size and type required for load conditions.
  - .1 Mounting Heights: Where mounting heights are not indicated, mount components at heights directed by the Consultant.
  - .2 Allow for building movement, including thermal expansion and contraction.
  - .3 Coordinate installation of anchorages. Furnish setting drawings, templates, and directions for installing anchorages, including sleeves, concrete inserts, anchor bolts, and items with integral anchors, that are to be embedded in concrete or masonry. Deliver such items to Project site in time for installation.
- .8 Joints: Make joints of uniform width. Where joint locations in exposed work are not indicated, arrange joints for the best visual effect. Fit exposed connections together to form hairline joints.
- .9 Repair or remove and replace damaged, defective, or nonconforming Work.

#### **1.06 FIRE-RATED ASSEMBLIES**

- .1 When penetrating fire rated walls, ceiling, or floor assemblies, completely seal voids with fire-stopping materials, smoke seals, or both, in full thickness of the construction element as required to maintain the integrity of the fire rated assembly.

**1.07 STARTING AND ADJUSTING**

- .1 Coordinate startup and adjusting of equipment and operating components with requirements where specified in other Specification sections or the Drawings.
- .2 Start equipment and operating components to confirm proper operation. Remove malfunctioning units, replace with new units, and retest.
- .3 Adjust equipment for proper operation. Adjust operating components for proper operation without binding.
- .4 Test each piece of equipment to verify proper operation. Test and adjust controls and safeties. Replace damaged and malfunctioning controls and equipment.
- .5 Manufacturer's Field Service: Comply with qualification requirements in Section 01 40 00 - Quality Requirements.

**1.08 PROTECTION OF COMPLETED WORK AND WORK IN PROGRESS**

- .1 Adequately protect Work completed or in progress. Work damaged or defaced due to failure in providing such protection is to be removed and replaced, or repaired, as directed by the Consultant, at no increase in Contract Price.
- .2 Protect Work against damage by on-going construction processes, vandalism, and other causes.
- .3 Do not load or permit to be loaded any part of the Work with a weight or force that will endanger the safety or integrity of the Work.
- .4 Prevent dust and aerosol-producing procedures from contaminating air beyond application area, by providing temporary enclosures other control methods, as stipulated in Section 01 56 00 - Temporary Barriers and Enclosures. Arrange for shutdown of air handling units which have air intakes in the vicinity of the work. Take precautions to prevent dust from triggering fire alarm smoke detectors and plugging ducts and filters. If necessary, arrange for shutdown of this equipment. Prior to start of work, identify locations of air intakes and air-cooled mechanical and electrical equipment within and adjacent to the area of work and protect them from entry of dust and air borne particles from construction activity.
- .5 Comply with manufacturer's written instructions for temperature and relative humidity.

**END OF SECTION**

**1.01 RELATED REQUIREMENTS**

- .1 Technical Specifications: Ductwork Cleaning.

**1.02 REFERENCE STANDARDS**

- .1 National Fire Protection Agency
  - .1 NFPA 241, Standard for Safeguarding Construction, Alteration, and Demolition Operations

**1.03 REGULATORY REQUIREMENTS**

- .1 Comply with applicable regulatory requirements when disposing of waste materials.
- .2 Obtain permits from authorities having jurisdiction and pay disposal fees where required for disposal of waste materials and recyclables.

**1.04 GENERAL CLEANING REQUIREMENTS**

- .1 Conduct cleaning and disposal operations to comply with local ordinances and anti-pollution laws.
- .2 Provide adequate ventilation during use of volatile or noxious substances. Do not rely on building ventilation systems for this purpose.
- .3 Use only cleaning materials recommended by manufacturer of surface to be cleaned, and as recommended by cleaning material manufacturer.
- .4 Prevent cross-contamination during the cleaning process.
- .5 Notify the Consultant of the need for cleaning caused by Owner or other contractors.

**1.05 MATERIALS**

- .1 Use only cleaning materials recommended by manufacturer of surface to be cleaned, and as recommended by cleaning material manufacturer. If specific cleaning materials are not recommended, use cleaning materials that are not hazardous to health or property and that will not damage exposed surfaces.

**1.06 PROGRESSIVE CLEANING AND WASTE MANAGEMENT**

- .1 General: Clean Project site and work areas daily, including common areas. Enforce requirements strictly. Dispose of materials lawfully.
- .2 Coordinate progress cleaning for joint-use areas where Contractor and other contractors are working concurrently.
- .3 Maintain the Work in a tidy and safe condition, free from accumulation of waste materials and construction debris.
- .4 Provide appropriate, clearly marked, containers for collection of waste materials and recyclables.
- .5 Remove waste materials and recyclables from work areas, separate, and deposit in designated containers at end of each Working Day. Collect packaging materials for recycling or reuse.
- .6 Remove waste materials and recyclables from Place of the Work at regular intervals.

- .7 Containerize hazardous and unsanitary waste materials separately from other waste. Mark containers appropriately and dispose of legally, according to regulations.
  - .1 Use containers intended for holding waste materials of type to be stored.
- .8 Comply with requirements in NFPA 241 for removal of combustible waste materials and debris.
- .9 Clean interior building areas prior to start of finish work and maintain free of dust and other contaminants during finishing operations.
- .10 Schedule cleaning operations so that resulting dust, debris and other contaminants will not fall on wet, newly finished surfaces nor contaminate building systems.
- .11 Site: Maintain Project site free of waste materials and debris.

#### **1.07 FINAL CLEANING: READY-FOR-TAKEOVER**

- .1 Perform final cleaning and waste removal at time of applying for Ready-for-Takeover.
- .2 Before final cleaning, arrange a meeting at Place of the Work to determine the acceptable standard of cleaning. Ensure that Owner, Consultant, and Contractor are in attendance.
- .3 Remove from Place of the Work surplus Products, waste materials, recyclables, temporary work, and construction equipment not required to perform any remaining work.
- .4 Provide professional cleaning by a qualified, established cleaning company.
- .5 Lock or otherwise restrict access to each room or area after completing final cleaning in that area.
- .6 Re-clean as necessary areas that have been accessed by Contractor's workers prior to Owner occupancy.
- .7 Remove stains, spots, marks, and dirt from finished surfaces, electrical and mechanical fixtures, furniture fitments, walls, floors and ceilings.
- .8 Remove dust from lighting reflectors, lenses, lamps, bulbs, and other lighting surfaces.
- .9 Vacuum clean and dust exposed wall, floor, and ceiling surfaces.
- .10 Clean mechanical and other equipment. Replace filters for mechanical equipment if equipment is used during construction.
- .11 Clean interior window glass and frames.

#### **1.08 WASTE MANAGEMENT PLAN**

- .1 Waste Management Plan: The Contractor is encouraged to implement a Waste Management Plan to maximize recycling of construction wastes. As a minimum, recycling of the following designated materials are recommended.
  - .1 Corrugated cardboard, paper and packaging.
  - .2 Clean dimensional wood, palette wood.
  - .3 Concrete/Concrete Block/Asphalt.
  - .4 Scrap metals, including wire.
  - .5 Unpainted Gypsum board (separate and placed in separate designated containers).
  - .6 Glass and plastics.
  - .7 Beverage containers.
  - .8 Land clearing debris.
  - .9 Paint (to be returned to Paint Depot).

**1.9 HAZARDOUS WASTE**

- .1 Separate waste defined as hazardous from recyclable and reusable materials. Place hazardous materials in designated containers.
- .2 Handle, transport and dispose hazardous materials not scheduled for reuse or recycling in accordance with applicable regulations.
- .3 Unused chemicals, admixtures, additives, sealants, caulking, and surface coating materials must not be disposed of into sewer system, into streams, lakes, onto ground or in other location where it will pose health or environmental hazard.
- .4 Divert hazardous materials from landfill and dispose of at official hazardous material collections site.
- .5 Ensure emptied containers are sealed and stored safely for disposal away from children.
- .6 Unused or damaged glazing materials are not recyclable. These materials must not be disposed of with materials destined for recycling.

**1.10 WASTE MANAGEMENT AND DISPOSAL**

- .1 Dispose of waste materials and recyclables at appropriate municipal landfills and recycling facilities in accordance with applicable regulatory requirements.
- .2 Do not burn or bury waste materials at Place of the Work.
- .3 Do not dispose of volatile and other liquid waste such as mineral spirits, oil, paints and other coating materials, paint thinners, cleaners, and similar materials together with dry waste materials or on the ground, in waterways, or in storm or sanitary sewers. Collect such waste materials in appropriate covered containers, promptly remove from Place of the Work, and dispose of at recycling facilities or as otherwise permitted by applicable regulatory requirements.
- .4 Cover or wet down dry waste materials to prevent blowing dust and debris.

**END OF SECTION**

## 1.01 SUMMARY

- .1 Section Includes:
  - .1 Administrative procedures preceding Substantial Performance of the Work and Ready-for-Takeover.

## 1.02 RELATED REQUIREMENTS

- .1 CCDC 2-2020: For General Conditions 5.4 "Substantial Performance of the Work and Payment of Holdback," 5.5 "Final Payment," and 12.1 "Ready-For-Takeover."
- .2 Section 01 74 00 - Cleaning and Waste Management: As a prerequisite for Ready-For-Takeover.

## 1.03 PREREQUISITES TO SUBSTANTIAL PERFORMANCE OF THE WORK

- .1 The prerequisites to, and the procedures for, attaining Substantial Performance of the Work, or similar such milestone as provided for in the lien legislation applicable to the Place of the Work, shall be:
  - .1 in accordance with the lien legislation applicable to the Place of the Work.
- .2 Submittals Prior to Substantial Performance: Complete the following and submit to Consultant a minimum of ten days prior to requesting review for Substantial Performance. List items below that are incomplete at time of request.
  - .1 Certificates of Release: Obtain and submit releases from authorities having jurisdiction, permitting Owner unrestricted use of the Work and access to services and utilities. Include occupancy permits, operating certificates, and similar releases.
  - .2 Submit closeout submittals specified in other Division 01 Sections, including Project Record Documents, operation and maintenance manuals, and similar final record information.
  - .3 Submit closeout submittals specified in individual Sections, including specific warranties, workmanship bonds, maintenance service agreements, final certifications, and similar documents.
  - .4 Submit maintenance material submittals specified in individual Sections, including tools, spare parts, extra materials, and similar items, and deliver to location designated by Owner. Label with manufacturer's name and model number.
    - .1 Schedule of Maintenance Material Items: Prepare and submit schedule of maintenance material submittal items, including name and quantity of each item and name and number of related Specification Section. Obtain Owner's signature for receipt of submittals.
  - .5 Submit testing, adjusting, and balancing records.
  - .6 Submit changeover information related to Owner's occupancy, use, operation, and maintenance.
- .3 Procedures Prior to Substantial Performance: Complete the following and submit to Consultant a minimum of ten days prior to requesting review for Substantial Performance. List items below that are incomplete at time of request.
  - .1 Advise Owner of pending insurance changeover requirements.
  - .2 Complete start-up and testing of systems and equipment.

- .3 Perform preventive maintenance on equipment used prior to Substantial Performance.
- .4 Instruct Owner's personnel in operation, adjustment, and maintenance of products, equipment, and systems.
- .5 Participate with Owner in conducting inspection and walkthrough with local emergency responders.
- .6 Terminate and remove temporary facilities from Project site, along with construction tools and similar elements.
- .7 Touch up paint and otherwise repair and restore marred exposed finishes to eliminate visual defects.

#### **1.04 INSPECTION AND REVIEW FOR SUBSTANTIAL PERFORMANCE OF THE WORK**

- .1 Contractor's Inspection: Before applying for the Consultant's review to establish Substantial Performance of the Work:
  - .1 Contractor and all Subcontractors shall conduct an inspection of the Work, identify deficiencies and defects, and repair as required to conform to Contract Documents.
  - .2 Notify Consultant in writing of satisfactory completion of Contractor's inspection and that corrections have been made and that the building is clean and in condition ready for occupancy.
  - .3 Request Consultant's Inspection.
- .2 Consultant's Review: Upon receipt of the Contractor's application for review, together with the Contractor's list of items to be completed or corrected, the Consultant and the Contractor shall arrange a mutually satisfactory agreed date and time to jointly review the Work. The Consultant will advise the Contractor whether or not the Work is Substantially Complete. Add additional items, if any, to the Contractor's list of items to be completed or corrected. Provide the Consultant with a copy of the revised list.
- .3 Maintain the list of items to be completed or corrected and promptly correct or complete defective, deficient and incomplete work. The Contractor's inspection and Consultant's review procedures specified above shall be repeated until the Work is Substantially Complete and no items remain on the Contractor's list of items to be completed or corrected.
- .4 Declaration of Substantial Performance of the Work: When Consultant considers deficiencies and defects have been corrected and it appears requirements of Contract have been substantially performed, Contractor shall make application for certificate of Substantial Performance of the Work.
- .5 Commencement of Lien and Warranty Periods: Date of Owner's acceptance of submitted declaration of Substantial Performance shall be the date for commencement of warranty period and commencement of lien period unless required otherwise by lien statute of Place of Work.
- .6 Payment of Holdback: After issuance of certificate of Substantial Performance of Work, submit an application for payment of holdback amount in accordance with GC 5.4.

#### **1.05 PREREQUISITES TO READY-FOR-TAKEOVER**

- .1 The prerequisites to attaining Ready-for-Takeover of the Work are described in the General Conditions of the Contract GC 12.1.

#### **1.06 INSPECTION AND REVIEW BEFORE READY-FOR-TAKEOVER**

- .1 Contractor's Inspection: Before applying for the Consultant's review to establish Ready-for-Takeover of the Work:

- .1 Ensure that the specified prerequisites to Ready-for-Takeover of the Work are completed.
  - .2 Conduct an inspection of the Work to identify defective, deficient, or incomplete work.
  - .3 Prepare a comprehensive and detailed list of items to be completed or corrected.
  - .4 Provide an anticipated schedule and costs for items to be completed or corrected.
- .2 Consultant's Review: Upon receipt of the Contractor's application for review, together with the Contractor's list of items to be completed or corrected, the Consultant and the Contractor shall arrange a mutually satisfactory agreed date and time to jointly review the Work. The Consultant will advise the Contractor whether the Work is Ready-for-Takeover. Add additional items, if any, to be added to the Contractor's list of items to be completed or corrected. Provide the Consultant with a copy of the revised list.
- .3 Maintain the list of items to be completed or corrected and promptly correct or complete defective, deficient and incomplete work. The Contractor's inspection and Consultant's review procedures specified above shall be repeated until the Work is Ready-for-Takeover and no items remain on the Contractor's list of items to be completed or corrected.
- .4 When the Consultant determines that the Work is Ready-for-Takeover, the Consultant will notify the Contractor and the Owner in writing to that effect.

**1.07 PREREQUISITES TO FINAL PAYMENT**

- .1 After Ready-for-Takeover of the Work and before applying for final payment in accordance with the General Conditions of Contract:
- .1 Correct or complete all remaining defective, deficient, and incomplete work.
  - .2 Remove from the Place of the Work all remaining surplus Products, Construction Equipment, and Temporary Work.
  - .3 Perform final cleaning and waste removal necessitated by the Contractor's work performed after Ready-for-Takeover, as specified in Section 01 74 00 - Cleaning and Waste Management.

**END OF SECTION**

## **1.01 SUMMARY**

- .1 Section Includes:
  - .1 Operation and maintenance manual requirements.
  - .2 Equipment and systems.
  - .3 Product data, materials and finishes, and related information.
  - .4 Spare parts, maintenance materials and special tools.
  - .5 As-built drawings.
  - .6 Project record drawings.
  - .7 Warranties and bonds.

## **1.02 RELATED REQUIREMENTS**

- .1 Section 01 40 00 - Quality Requirements.
- .2 Section 01 77 00 - Closeout Procedures.

## **1.03 ADMINISTRATIVE REQUIREMENTS**

- .1 Responsibilities of the Contractor:
  - .1 During the course of construction, record as-built conditions on Drawings and Specification section relative to the Work.
  - .2 Receive, review and collate operation and maintenance data during course of construction for inclusion into operation and maintenance manual.
  - .3 Prepare instructions and data using personnel experienced in maintenance and operation of described products.
  - .4 Follow requirements specified in this section for format and contents of operation and maintenance data.
  - .5 Prepare draft operation and maintenance manual and submit to Consultant six weeks prior to project Substantial Performance of the Work for review.
  - .6 Revise content of documents as directed by Consultant prior to final submittal.
  - .7 Prepare final operation and maintenance manual.
  - .8 Participate in post construction warranty events.
  - .9 Organize post construction warranty requirements.
- .2 Pre-Warranty Meeting:
  - .1 Meet with Consultant, to develop understanding of requirements of this Section. Consultant to schedule meeting prior to Substantial Performance of the Work.
  - .2 Consultant will establish communication procedures for:
    - .1 Notification of construction warranty defects.
    - .2 Determine priorities for type of defect.
    - .3 Determine reasonable time for response.
  - .3 Provide name, telephone number and address of licensed and bonded company that is authorized to initiate and pursue construction warranty work action.
  - .4 Ensure contact is located within local service area of warranted construction, is continuously available, and is responsive to inquiries for warranty work action.

**1.04 ACTION AND INFORMATIONAL SUBMITTALS**

- .1 Submit in accordance with Section 01 33 00 - Submittal Procedures.
- .2 Six weeks prior to Substantial Performance of the Work, submit to Consultant one digital PDF copy of the Operation and Maintenance manual, in the language of the Contract, and As-Built Documents for review. Prepare instructions and data using personnel qualified and experienced for this task.
- .3 Two weeks prior to Substantial Performance of the Work, submit one digital copy and one hard copy of the final Operation and Maintenance manual and As-Built Documents to the Owner. Submit digital copy of final Operation and Maintenance manual and As-Built Documents to the Consultant.
- .4 Provide spare parts, maintenance materials, and special tools of same quality and manufacture as products provided in Work.
- .5 Provide evidence, if requested, for type, source and quality of products supplied.

**1.05 OPERATION AND MAINTENANCE MANUAL FORMAT**

- .1 Organize data in the form of an instructional manual.
- .2 Hardcopy Submission:
  - .1 Binders: Vinyl, hard covered, three D-rings, loose leaf, 216 by 279 mm, with spine and face pockets.
  - .2 When multiple binders are used, correlate data into related consistent groupings.
    - .1 Identify contents of each binder on spine.
  - .3 Cover: Identify each binder with typed or printed title "Operation and Maintenance Manual", name of Project or facility, and subject matter of contents.
  - .4 Arrange content by systems under Section numbers and sequence of Table of Contents.
  - .5 Provide tabbed fly leaf for each separate Product or system, with typed description of Product and major component parts of equipment.
  - .6 Text: Manufacturer's printed data, or typewritten data.
  - .7 Drawings: Provide with reinforced punched binder tab. Bind in with text; fold larger drawings to size of text pages.
- .3 Electronic Submission:
  - .1 Provide PDF digital submission of all files organized as outlined in this section.
  - .2 Drawings: Provide 1:1 scaled CAD files
  - .3 in .dwg format.

**1.06 OPERATION AND MAINTENANCE MANUAL - GENERAL CONTENT**

- .1 Table of contents for each volume.
- .2 Introductory information including:
  - .1 Title of project.
  - .2 Date of manual submission.
  - .3 Addresses and telephone numbers for Consultant and Contractor, with names of responsible parties.
  - .4 Schedule of Products and systems indexed to content of volume.
- .3 For each Product or system:

- .1 List names, addresses, and telephone numbers for Subcontractors, Suppliers and manufacturers, including local sources for supplies and replacement parts.
- .4 Product Data: Mark each sheet to clearly identify specific products, options, and component parts, and data applicable to installation. Delete inapplicable information.
- .5 Drawings: Supplement product data to illustrate relations of component parts of equipment and systems, to show control and flow diagrams.
- .6 Typewritten Text: As required to supplement product data.
  - .1 Provide logical sequence of instructions for each procedure, incorporating manufacturer's operating and maintenance instructions.
- .7 Permits, certificates, letters of assurance and other relevant documents issued by or required by authorities having jurisdiction.
- .8 Warranties.
- .9 Training materials as specified in Section 01 79 00 - Demonstration and Training.

**1.07 OPERATION AND MAINTENANCE MANUAL - PRODUCTS AND FINISHES CONTENT**

- .1 Building products, applied materials, and finishes: include Product data, with catalogue number, options selected, size, composition, and colour and texture designations.
  - .1 Provide information for re-ordering custom manufactured Products.
- .2 Instructions for cleaning agents and methods, precautions against detrimental agents and methods, and recommended schedule for cleaning and maintenance.
- .3 Moisture-protection and weather-exposed products: include manufacturer's recommendations for cleaning agents and methods, precautions against detrimental agents and methods, and recommended schedule for cleaning and maintenance.
- .4 Include additional content as specified in technical Specifications Sections or Drawings.

**1.08 OPERATION AND MAINTENANCE MANUAL – EQUIPMENT AND SYSTEMS CONTENT**

- .1 Each Item of Equipment and Each System:
  - .1 Include description of unit or system and component parts.
  - .2 Give function, normal operation characteristics, and limiting conditions.
  - .3 Include performance curves, with engineering data and tests, and complete nomenclature and commercial number of replaceable parts.
- .2 Panel Board Circuit Directories: Provide electrical service characteristics, controls, and communications.
- .3 Include installed colour coded wiring diagrams.
- .4 Operating Procedures:
  - .1 Include start-up, break-in, and routine normal operating instructions and sequences.
  - .2 Include regulation, control, stopping, shut-down, and emergency instructions.
  - .3 Include summer, winter, and any special operating instructions.
- .5 Maintenance Requirements: Include routine procedures and guide for trouble-shooting; disassembly, repair, and reassembly instructions; and alignment, adjusting, balancing, and checking instructions.
- .6 Provide servicing and lubrication schedule, and list of lubricants required.

- .7 Include manufacturer's printed operation and maintenance instructions.
- .8 Include sequence of operation by controls manufacturer.
- .9 Provide original manufacturer's parts list, illustrations, assembly drawings, and diagrams required for maintenance.
- .10 Provide installed control diagrams by controls manufacturer.
- .11 Provide Contractor's coordination drawings, with installed colour coded piping diagrams.
- .12 Provide charts of valve tag numbers, with location and function of each valve, keyed to flow and control diagrams.
- .13 Provide list of original manufacturer's spare parts, current prices, and recommended quantities to be maintained in storage.
- .14 Include testing and balancing reports as specified in Section 01 40 00 - Quality Requirements.
- .15 Include additional content as specified in technical Specifications sections.

**1.09 OPERATION AND MAINTENANCE MANUAL - WARRANTIES CONTENT**

- .1 Separate each warranty with index tab sheets keyed to Table of Contents listing.
- .2 List each warrantor with complete contact information.
- .3 Verify that documents are in proper form and contain full information. Ensure that warranties are for the correct duration and are in Owner's name.

**1.10 AS-BUILT DOCUMENTS AND SAMPLES**

- .1 Maintain at site for Owner and Consultant, one record copy of:
  - .1 Contract Drawings.
  - .2 Specifications.
  - .3 Addenda.
  - .4 Change Orders and other modifications to Contract.
  - .5 Reviewed shop drawings, product data, and samples.
  - .6 Field test records.
  - .7 Inspection certificates.
  - .8 Manufacturer's certificates.
- .2 Store record documents and samples in field office apart from documents used for construction.
  - .1 Provide files, racks, and secure storage.
- .3 Label record documents and file in accordance with section number listings in Table of Contents of this Project Manual.
  - .1 Label each document "PROJECT RECORD" in neat, large, printed letters.
- .4 Maintain record documents in clean, dry and legible condition.
  - .1 Do not use record documents for construction purposes.
- .5 Keep record documents and samples available for inspection by Owner and Consultant.
- .6 Submit one copy of completed record drawings in both hard copy and electronic forms to Owner. Provide electronic record drawings to Consultant.

### **1.11 RECORDING INFORMATION ON PROJECT RECORD DOCUMENTS**

- .1 Record information on set of black line opaque drawings, and in copy of Project Manual, provided by Consultant.
- .2 Use felt tip marking pens, maintaining separate colours for each major system, for recording information.
- .3 Record information concurrently with construction progress.
  - .1 Do not conceal Work until required information is recorded.
- .4 Contract Drawings and Shop Drawings: Mark each item to record actual construction, including:
  - .1 Measured depths of elements of foundation in relation to finish first floor datum.
  - .2 Measured horizontal and vertical locations of underground utilities and appurtenances, referenced to permanent surface improvements.
  - .3 Measured locations of internal utilities and appurtenances, referenced to visible and accessible features of construction.
  - .4 Field changes of dimension and detail.
  - .5 Changes made by change orders.
  - .6 Details not on original Contract Drawings.
  - .7 References to related shop drawings and modifications.
- .5 Specifications: Mark each item to record actual construction, including:
  - .1 Manufacturer, trade name, and catalogue number of each product actually installed, particularly optional items and substitute items.
  - .2 Changes made by Addenda and change orders.
- .6 Other Documents: Maintain manufacturer's certifications, inspection certifications, field test records, required by individual specifications sections.
- .7 Provide digital photos, if requested, for site records.
- .8 At completion of project and prior to final review, neatly transfer "as-built" notations to second and third set of black line opaque drawings and submit to Consultant along with field drawings. In addition, submit AutoCAD disks of project with all changes included to reflect "as-built" conditions. Drawings must be generated in most current AutoCAD version, and consistent with Bid Documents.
  - .1 For Subcontractors' use in preparation of "as-built" drawings required under this contract, Subcontractors may purchase from Consultant, electronic AutoCAD drawing files subject to the following:
    - .1 Removal by Consultant of Consultants' professional seals from electronic drawing file; and
    - .2 Receipt of Licence Agreement prepared by Consultant and signed by Contractor(s) or user(s) of electronic files; and
    - .3 Receipt of payment to Consultant from each separate Subcontractor requesting an electronic drawing file, an amount of \$250.00 for first electronic file or drawing sheet requested plus an additional \$200.00 for each subsequent electronic file or drawing sheet requested at same time.

### **1.12 SPARE PARTS, MAINTENANCE MATERIALS, AND SPECIAL TOOLS**

- .1 Spare Parts:
  - .1 Provide spare parts, in quantities specified in individual specification sections.

- .2 Provide items of same manufacture and quality as items in Work.
- .3 Deliver to site; place and store where directed by Owner.
- .4 Receive and catalogue all items:
  - .1 Submit inventory listing to Consultant.
  - .2 Include approved listings in Maintenance Manual.
- .5 Obtain receipt for delivered products and submit prior to final payment.
- .2 Maintenance Materials:
  - .1 Provide maintenance and extra materials, in quantities specified in individual specification sections.
  - .2 Provide items of same manufacture and quality as items in Work.
  - .3 Deliver to site; place and store where directed by Owner.
  - .4 Receive and catalogue all items:
    - .1 Submit inventory listing to Consultant.
    - .2 Include approved listings in Maintenance Manual.
  - .5 Obtain receipt for delivered products and submit prior to final payment.
- .3 Special Tools:
  - .1 Provide special tools, in quantities specified in individual Specification Section.
  - .2 Provide items with tags identifying their associated function and equipment.
  - .3 Deliver to site; place and store where directed by Owner.
  - .4 Receive and catalogue all items:
    - .1 Submit inventory listing to Consultant.
    - .2 Include approved listings in Maintenance Manual.
- .4 Storage, Handling and Protection:
  - .1 Store spare parts, maintenance materials, and special tools in manner to prevent damage or deterioration.
  - .2 Store in original and undamaged condition with manufacturer's seal and labels intact.
  - .3 Store components subject to damage from weather in weatherproof enclosures.
  - .4 Store paints and freezable materials in a heated and ventilated room.
  - .5 Remove and replace damaged products at own expense and to satisfaction of Consultant.

### **1.13 WARRANTIES AND BONDS**

- .1 Separate each warranty or bond with index tab sheets keyed to Table of Contents listing.
- .2 List Subcontractor, Supplier, and manufacturer, with name, address, and telephone number of responsible principal.
- .3 Obtain warranties and bonds, executed in duplicate by Subcontractors, Suppliers, and manufacturers, within ten days after completion of the applicable item of work.
- .4 Except for items put into use with Owner's permission, leave date of beginning of time of warranty until Ready-for-Takeover date is determined.
- .5 Verify that documents are in proper form, contain full information, and are notarized.
- .6 Co-execute submittals when required.
- .7 Retain warranties and bonds until time specified for submittal.

**END OF SECTION**

### **1.01 SUMMARY**

- .1 Section includes administrative and procedural requirements for instructing Owner's personnel, including the following:
  - .1 Demonstration of operation of systems, subsystems, and equipment.
  - .2 Training in operation and maintenance of systems, subsystems, and equipment.

### **1.02 RELATED REQUIREMENTS**

- .1 Divisions 13, 23, 25, and 26: For specific requirements for demonstration and training for products in those Sections.

### **1.03 ADMINISTRATIVE REQUIREMENTS**

- .1 Demonstrate operation and maintenance of equipment and systems to Owner's personnel two weeks prior to date of Substantial Performance of the Work.
- .2 Owner: Provide list of personnel to receive instructions, and co-ordinate their attendance at agreed-upon times.
- .3 Preparation:
  - .1 Verify conditions for demonstration and instructions comply with requirements.
  - .2 Verify designated personnel are present.
  - .3 Ensure equipment has been inspected and put into operation.
  - .4 Ensure testing, adjusting, and balancing has been performed and equipment and systems are fully operational.
- .4 Demonstration and Instructions:
  - .1 Record attendance in training sessions with Trainee signature upon completion.
  - .2 Demonstrate start-up, operation, control, adjustment, trouble-shooting, servicing, and maintenance of each item of equipment at agreed upon times, at the equipment location.
  - .3 Instruct personnel in phases of operation and maintenance using operation and maintenance manuals as basis of instruction.
  - .4 Review contents of manual in detail to explain aspects of operation and maintenance.
  - .5 Prepare and insert additional data in operations and maintenance manuals when needed during instructions.
- .5 Time Allocated for Instructions: Ensure amount of time required for instruction of each item of equipment or system as indicated in article 1.14.

### **1.04 ACTION AND INFORMATIONAL SUBMITTALS**

- .1 Provide submittals in accordance with Section 01 33 00 - Submittal Procedures.
- .2 Submit schedule of time and date for demonstration of each item of equipment and each system two weeks prior to designated dates, for Consultant's approval.
- .3 Submit reports within one week after completion of demonstration, that demonstration and instructions have been satisfactorily completed.
- .4 Give time and date of each demonstration, with list of persons present.

- .5 Provide copies of completed operation and maintenance manuals for use in demonstrations and instructions.

**1.05 CLOSEOUT SUBMITTALS**

- .1 Submit in accordance with Section 01 78 00 - Closeout Submittals.

**1.06 QUALITY ASSURANCE**

- .1 When specified in individual Sections requiring manufacturer to provide authorized representative to demonstrate operation of equipment and systems:
  - .1 Instruct Owner's personnel.
  - .2 Provide written report that demonstration and instructions have been completed.
- .2 Instructor Qualifications: A factory-authorized service representative experienced in operation and maintenance procedures and training.

**1.07 PREREQUISITES TO DEMONSTRATION AND TRAINING**

- .1 Testing, adjusting, and balancing has been performed in accordance with Contract Documents.
- .2 Equipment and systems are fully operational.
- .3 Copy of completed operation and maintenance manual is available for use in demonstration and training.
- .4 Conditions for demonstration and training comply with requirements specified in technical Specifications.

**1.08 DEMONSTRATION AND TRAINING**

- .1 Demonstrate start up, operation, control, adjustment, trouble-shooting, servicing, and maintenance of each item of equipment and system.
- .2 In addition to start-up supervision and start-up instruction of Owner's personnel required of individual equipment manufacturers and systems as noted, instruct Owner's personnel to whatever depth necessary to fully understand operation and maintenance of all equipment and systems provided.
- .3 Review instruction with Owner's representative to ensure a thorough understanding of equipment and its operation.

**1.09 ORIENTATION**

- .1 Provide orientation sessions to Owner's personnel to familiarize personnel with the theory of operation and sequence of operations of major pieces of equipment and systems (e.g. electrical, mechanical, etc.)
- .2 Orientation to consist of both classroom and on-site sessions.
- .3 Instructors: Fully prepared to provide sessions of duration indicated with intensive training for each major system.
  - .1 Provide additional training as required to ensure trainees have thorough understanding of system and equipment operation and trouble shooting.
- .4 Instructors to provide necessary audio-visual equipment, and education training aids (literature, drawings, schematics, etc.) to convey thorough understanding of system or equipment operation and troubleshooting.

- .5 Instructors to briefly review proposed training material and format with Owner prior to commencement.

#### **1.10 ORIENTATION AND TRAINING**

- .1 Qualifications of Suppliers' Representatives:
  - .1 Instructor of equipment supplier or manufacturer must be a technical person fully versed in design criteria and be fully qualified to give instruction in operation and maintenance of the equipment.
  - .2 Persons receiving orientation may be divided into three groups. Supplier may be requested to address these groups separately.
    - .1 First group composed of users who operate the equipment. They do not carry out any maintenance or repair. They call a service technician to address any problems encountered.
    - .2 Second group composed of service technicians. Technicians do routine maintenance and minor repairs. They also answer trouble calls and are required to make preliminary checks. If problem is beyond their control, they are required to call in tradesman and require more extensive training.
    - .3 Third group are the tradesmen. This group composed of electricians, mechanics, refrigeration mechanics, electronic technicians. They do tuning and major repairs.
    - .4 Orientation and training must be aimed specifically at these groups.

#### **1.11 ORIENTATION SESSION FORMAT**

- .1 User Group Level:
  - .1 Identify and explain purpose of installation.
  - .2 Identify and explain all controls including remote controls and alarms,
  - .3 identifying their locations and purpose.
  - .4 Explain sequence of operation and identify setpoints.
  - .5 Hands on try-outs for each person.
  - .6 Discuss most common failures and faults requiring technician support.
  - .7 Questions and answers.
- .2 Maintenance Technicians Level:
  - .1 Identify and explain purpose of installation.
  - .2 Identify and explain all controls including remote controls and alarms, identifying their locations.
  - .3 Explain sequence of operation and identify setpoints.
  - .4 Hands on try-outs for each person.
  - .5 Discuss most common failures and faults.
  - .6 Describe routine maintenance procedures.
  - .7 Describe routine repair procedures.
  - .8 Describe troubleshooting procedures.
  - .9 Questions and answers.
- .3 Tradesman Level:
  - .1 Identify and explain purpose of installation.

- .2 Identify all components using drawings and schematics.
- .3 Explain detailed sequence of operation, identify all control variables and parameters.
- .4 Identify and explain all setpoints and method of selection with hands on instruction.
- .5 Discuss most common problems and corrective actions.
- .6 Ensure complete understanding of all procedures, data and graphs.
- .7 Questions and answers.

**1.12 PRESENTATION PREPARATION**

- .1 Orientation shall be carefully planned prior to presentation to ensure thorough coverage in limited time periods available.
- .2 Provide a presentation outline and sample presentation visual, and handout materials to Owner before confirming presentation dates and locations.
- .3 Orientation to include visual materials such as drawings, diagrams, and printed handouts.
- .4 Instructors to provide the necessary audio-visual equipment and other aids necessary to convey thorough understanding of system and/or equipment operation and troubleshooting.

**1.13 TIME ALLOCATED FOR INSTRUCTION**

- .1 Ensure amount of time required for instruction of each item of equipment or system as follows:
  - .1 Divisions 13, 23 ,24, and 25:
    - .1 2 hours per system.
  - .2 Division 26
    - .1 2 hours per system.

**END OF SECTION**

## **PART 1 - GENERAL**

### **1.01 RELATED DOCUMENTS**

- A. The BIDDING REQUIREMENTS, CONTRACT FORMS, AND CONDITIONS OF THE CONTRACT and applicable parts of DIVISION 1 - GENERAL REQUIREMENTS, as listed in the Table of Contents, be included in, and made a part of this Section.

### **1.02 SUMMARY OF WORK (for general guidance-not inclusive)**

- A. Introduction
  - 1. Provide labor, materials, equipment, and services necessary to renovate the pool and hot tub mechanical and chemical equipment. This work must include installation of products listed in Part 2 of Section 131100.
- B. Work included in this section:
  - 1. It is the intent of this section to place the entire responsibility for the renovation of the pool(s) under one vested Contractor. Under this section the Contractor will provide but is not necessarily limited to the following:
    - a. Provide equipment and services required for erection and delivery onto the premises the equipment or apparatus provided. Remove equipment from premises when no longer required.
    - b. Provide electrical conduit, wiring, junction boxes etc. to low voltage pool equipment within pool filter/chemical rooms per Division 26 - Electrical. (Low voltage is considered less than 110 V.)
    - c. Coordinate for required bonding and grounding of the pool equipment.
    - d. Provide necessary piping and valving as shown on the drawings and specified herein.
    - e. Provide individually sized housekeeping pad for the new competition pool filter as required in the drawings.
    - f. Provide for the storage of pool related equipment, materials, and systems. Items are the responsibility of the Contractor until accepted by the owner.
    - g. Obtain final acceptance by jurisdictional health department(s).
    - h. Start, test, calibrate and adjust mechanical equipment, electrical equipment, recirculation, chemical, and other supplied systems. Instruct the Owner's representative in the systems operation and maintenance as described herein.
- C. Related work specified in other sections:
  - 1. Section 131105 – Selective Demolition
- D. Related work specified in Electrical sections. Reference Division 26 – Electrical. Work that must be completed by others.
  - 1. Ground and bond new pool equipment. Test and verify that the system electrical ground is true and solid. Provide certification to this effort.
  - 2. Obtain permits, inspections, and approvals of wiring including grounding and bonding of metal components associated with the pool in accordance with governing Electrical Codes.

### **1.03 REGULATORY AGENCY REQUIREMENTS AND ENGINEERING SERVICES**

- A. The system must comply with necessary pre-construction approvals.

- B. Give necessary notices, obtain permits, pay government fees, and other costs in connection with his work, including the filing of necessary as-built drawings, prepare documents (including any amendments to the approved construction documents) and obtain necessary approvals of governmental departments having jurisdiction over their work. Obtain required certificates of inspection for his work and deliver copies to the Owner and Architect before requesting acceptance and final payment for the work.
- C. Include in the work, without extra cost to the Owner, labor, materials, services, apparatus, or drawings in order to comply with applicable laws, ordinances, rules, and regulations, whether or not shown on drawings and/or specified.

#### **1.04 COORDINATION AND CLARIFICATION**

- A. Coordinate with other trades' work relating to this section.
- B. Must establish with other trades, having related work in this section, that work necessary to complete the pool(s) as shown on the drawings and in the specifications is included in the base bid and alternates to the Owner.
- C. If in doubt regarding the responsibility for work covered in this section and/or discovery of errors or omissions in the bidding documents, notify the Architect through channels established by the specifications and request a clarification ten (10) days prior to the bid date.

#### **1.05 ALTERNATES**

- A. Review the description of the alternates in Division 1 and on the drawings for possible effect upon work in this section. Alternates related to the work in this section are described in this division and on the bid proposal form.
- B. Pool Alternates – Refer to specification section 011100 for further information regarding working included/omitted from this contract as well as any add/deduct alternates.

#### **1.06 CONTRACTOR'S ALTERNATE PROPOSAL**

- A. Submit bid to the owner based on materials, equipment and methods as specified in this Section. No substitution of material will be allowed.
- B. It is the intent of the contract documents to encourage competition. The base proposal must include the construction methods and equipment as specified and detailed. Proposed system substitutions must have prior written approval by the Architect.
- C. If there is a deviation from the basis of design equipment, confirm that engineering criteria are appropriate for the substituted equipment.
- D. Substitutions of specified construction methods and equipment must include a complete submittal as required by these specifications and drawings of appropriate scale incorporating required changes. Provide a list of at least ten (10) satisfactory installations comparable to this project that have been manufactured and installed under the manufacturer's current legal name. Submit a list of such projects with the name, address and current telephone number of the Owner's Operator and Architect of Record to the Architect on the bid date.
- E. Changes or modifications to the Contract Documents that are not authorized by the architect are the sole responsibility of the Contractor.

#### **1.07 SUBMITTALS**

- A. Submittals must be made in accordance with the requirements of Division 1 - General Requirements and in strict compliance with the following procedures and guidelines.
- B. One (1) set of shop drawings and engineering data must be tabbed, indexed, and referenced to the specifications, compiled into an electronic submittal, and submitted in two stages. The first stage

must include items for the pool shell(s), reference swimming pool structural specifications. The second stage must be for remaining items. Each section of items must be prefaced by a cover sheet listing the items submitted within the section. Electronic submittals must be organized, numbered, and submitted in the same format and order as the project specifications. Only complete sets will be reviewed.

1. Engineering data covering systems, equipment, structures, and fabricated materials, which will become a permanent part of the work under this contract, must be submitted for review. This data must include drawings and descriptive information in sufficient detail and scale to show the kind, size, arrangement, and operation of component materials and devices; the external connections, anchorage and supports required; performance characteristics; fabrication and dimensions needed for installation and correlation with other materials and equipment. A certification, in writing, must be provided indicating that equipment will fit in the space allotted and as shown on the drawings.
2. Submittals regardless of origin must be stamped with the approval of the Contractor and identified with the name and number of this contract, Contractor's name, and references to applicable specification paragraphs and contract drawings. Each submittal must indicate the intended use of the item in the work. When catalog pages are submitted, applicable items must be clearly identified. The current revision, issue number, and date must be indicated on drawings and other descriptive data.
3. The submittals will not be accepted from anyone but the Contractor. Submittals must be consecutively numbered in direct sequence of submittal and without division by subcontracts or trades.
4. The Contractor's stamp of approval is a representation that the Contractor accepts full responsibility for determining and verifying quantities, dimensions, field construction criteria, materials, catalog numbers and similar data, and that he has reviewed or coordinated each submittal with the requirements of the work and the contract documents.
5. Each submittal must include a statement prepared by the originator of the drawings and data, certifying compliance with the contract documents except for deviations, which are specifically identified.
6. Deviations from the contract documents must be identified on each submittal and must be tabulated in the Contractor's letter of transmittal. Such submittals must, as pertinent to the deviation, indicate essential details of changes by the Contractor (including modifications to other facilities that may be a result of the deviation) and required piping and wiring diagrams.
7. The Contractor must accept full responsibility for the completeness of each submission, and, in the case of a resubmission, must verify that exceptions previously noted have been considered.
8. The need for more than one resubmission, or a delay in obtaining review of submittals, will not entitle the Contractor to an extension of the contract time unless the delay of the work is directly caused by a change in the work authorized by a change order.
9. Review of drawings and data submitted by Contractor will cover only general conformity to the drawings and specifications, external connections and dimensions that affect the layout. Review does not indicate a thorough review of dimensions, quantities, and details of the material, equipment, device, or item shown. Review of submittals does not relieve Contractor from responsibility for errors, omissions, or deviations, or responsibility for compliance with the contract documents.
10. When the drawings and data are returned marked REJECTED, REVISE AND RESUBMIT or SUBMIT SPECIFIED ITEM, the corrections must be made as noted thereon and as instructed and six corrected copies (or one copy and one corrected reproducible copy) resubmitted.

11. Resubmittals must bear the number of the first submittal followed by a letter (A, B, etc.) to indicate the sequence of the resubmittal. Resubmittals must be indexed, tabbed, referenced to the specifications, and bound in a three-ring binder and submitted at one time.
  12. When corrected copies are resubmitted, the Contractor must, in writing, direct specific attention to revisions and must list separately revisions made other than those called for on previous submissions.
  13. When the drawings and data are returned marked NO EXCEPTIONS TAKEN or MAKE CORRECTIONS NOTED, no additional copies are to be provided unless specifically requested to do so for record.
- C. Permits, Receipts and Test Reports
1. Provide the Architect with copies of permits and receipts for fee payments.
  2. Submit a sample format for each test report intended for use. Submit test reports required herein only on approved forms.
- D. Include complete product data indexed, tabbed, and referenced to specifications with 8 1/2" x 11" cover sheet covering:
1. Paragraph 2.01 - Filtration Equipment
  2. Paragraph 2.02 - Piping Systems
  3. Paragraph 2.03 - Chemical Treatment Systems
  4. Paragraph 2.04 - Flow Meters
- E. Reference Section 131105 - Selective Demolition

#### **1.08 OPERATION AND MAINTENANCE MANUALS AND CLOSE-OUT SUBMITTALS**

- A. Detailed operation and maintenance information must be supplied for equipment requiring maintenance or other attention. The equipment supplier and/or the Contractor must prepare an operation and maintenance manual for equipment. Parts lists and operating, and maintenance instructions must be provided.
- B. Each operation and maintenance manual must include the following:
1. Equipment function and calibration, normal operating characteristics, and limiting conditions.
  2. Assembly, installation, alignment, adjustment and checking instructions.
  3. Operating instructions for startup, routine and normal operation, regulation, and control, shut down and emergency conditions.
  4. One (1) copy of instructional videos.
  5. One (1) copy of Safety Data Sheet forms for all pool chemicals provided.
  6. Operating cycles must be specifically described in outline format and in referenced detail. A wall-mounted color-coded piping flow diagram must be provided in the pool equipment room. The diagram must be engraved on laminated plastic with color-coded piping to match the color of coding on piping, and including valves identified with number on tags. The minimum size is 11-inch x 17 inch.
  7. Include manufacturer recommended maintenance schedule, parts lists, piping diagram (to agree with wall mounted diagram) and trouble-shooting information for pool mechanical equipment.
  8. Using reference to keyed valves and wall diagram, include specific written instructions for procedures that must be followed for the following:

- a. Filter operation and backwashing; and
- b. Super chlorination.
- 9. Lubrication and maintenance instructions.
- 10. Guide to "troubleshooting."
- 11. Parts list and predicted life of parts subject to wear.
- 12. Outline, cross section, and assembly drawings; engineering data and wiring diagrams.
- 13. Test data and performance curves, where applicable.
- 14. Specific written instructions for procedure for emptying and refilling the pool(s) including de-watering during the period that the pool will be empty. Provide a yellow warning sign 8-1/2 in. x 11 in., that must be mounted in the pool mechanical room, that reads:

Keep Caps, Plugs and Tops Tight Fitting to Prevent Escape of Fumes.

- 15. Additionally, provide the following signs mounted on the chemical room doors:
  - a. NFPA Hazard Diamond for each chemical stored in room.
  - b. Warning: Authorized Personnel Only Beyond This Point
  - c. Signage indicating location of associated Safety Data Sheet forms for all chemicals stored in room.
- 16. One set of applicable submittals must be included in each manual.
- C. The operation and maintenance manuals must be in addition to instructions or parts lists packed with or attached to the equipment when delivered, or which may be required by the Contractor.
- D. Manuals and other data must be printed on heavy, first quality paper, 8-1/2 x 11-inch size with standard 3-hole punching and inserted in plastic covers. Drawings and diagrams must be reduced to 8-1/2 x 11 inches or 11 x 17 inches. Where reduction is not practical, larger drawings must be folded separately and placed in envelopes that are bound into the manuals. Each envelope must bear suitable identification on the outside.
- E. Two (2) bound volumes of each manual must be submitted. Parts lists and information must be assembled in substantial manuals and permanent, three-ring or three-post binders. Material must be assembled and bound in the same order as specified, and each volume must have a table of contents and suitable index tabs.
- F. Material must be marked with project identification. Non-applicable information must be marked out or deleted.
- G. Shipment of equipment will not be considered complete until the required manuals and data have been received.

#### **1.09 PRODUCT DELIVERY, STORAGE, AND HANDLING**

- A. Deliver material in manufacturer's original, unopened containers and crates with labels intact and legible.
- B. Deliver materials in sufficient time and quantity to allow continuity of work and compliance with approved construction schedule.
- C. Handle materials in a manner to prevent damage.
- D. Store materials on clean raised platforms with weather protective coverings. Provide continuous protection of materials against damage or deterioration.
- E. Remove damaged materials from site.

### **1.10 WARRANTIES**

- A. The Contractor warrants to the Owner and Architect that materials and equipment provided under the contract will be of good quality and new unless otherwise required or permitted by the contract documents, that the work will be free from defects not inherent in the quality required or permitted, and that the work will conform with the requirements of the contract documents. Work not conforming to these requirements, including substitutions not properly approved and authorized will be considered defective. The Contractor's warranty will exclude remedies for damage or defect caused by abuse, improper or insufficient maintenance, improper operations, modifications not executed by the Contractor or improper wear and tear under normal use. If required by the Architect, provide satisfactory evidence as to the kind and quality of materials and equipment.
- B. The Contractor must agree to repair or replace defective or non-complying work at no cost to the Owner upon written notification from the Owner within the warranty period. Pro-rated warranties are not acceptable.
- C. Warranties must be for a period of one year from the date of substantial completion or the owner begins using the pool unless otherwise specified. Submit warranties covering, but not limited to the following:
  - 1. Defects in material, manufacture and installation of the backwash, chlorination, and pH adjustments, including controls for a period of one (1) year.
  - 2. Manufacturer's minimum fifteen (15) year warranty on the filter tank against defective materials or workmanship of the tank and components. Prorated warranties are not acceptable
  - 3. Defects in material, workmanship, and installation of the pool piping system for a period of three (3) years.
  - 4. Manufacturer's minimum one (1) year warranty against defective materials, components, and workmanship in the sanitizing feed system.
  - 5. Manufacturer's minimum one (1) year warranty against defective materials, components, and workmanship in the pH buffer feed system.
  - 6. Manufacturer's minimum three (3) year warranty against defective materials, components, and workmanship in the Clear-Flow Electronic Flocculation System (EFS).

### **1.11 SYSTEM TRAINING**

- A. A qualified representative of the Contractor performing work under this section must put the equipment into operation and instruct the Owner's representatives in the operation of this equipment to the Owner's satisfaction immediately after project's substantial completion.
- B. The Contractor's training representative must have completed the equipment/system's manufacturer's training requirements and be certified, by the manufacturer, to provide and teach system training.
- C. The representative from the Contractor must be either a CPO (Certified Pool Operator) or have an AFO (Aquatic Facility Operator) certification.
- D. Training period consists of 8 hours of on-site training and is scheduled as follows:
  - 1. 8 hours of training on the renovated swimming pool equipment and water chemistry. The 8 hours of training must be comprised of at least 2 hours of training on water chemistry analysis and adjustment. The water chemistry training will include in-depth review of the use of the Langlier index and its computation.
  - 2. The initial 8 hours of training must include information on the care, operation, adjustment, and maintenance of items provided by the Contractor under the "Part 2 – Products" section of this specification.

3. Provide a project specific video recording instruction manual in addition to the training sessions. The video instructions must be project specific and must include information on the care, operation, adjustment, and maintenance of items provided by the Contractor under the "Part 2 – Products" section of this specification. This video recording must be done separate from the Owner training.
4. The Contractor must include one (1) copy of video recording instructions in each Operations and Maintenance Manual.

#### **1.12 POOL FILL WATER QUALITY**

- A. The Owner is to bear the cost of the water required for one (1) complete filling of the pool (the final filling). Removal of iron or copper (if in excess of .3 ppm) will be required for the final fill to avoid staining of the pool finish. Subsequent fillings or partial fillings (more than 25%) of the pool is by the Contractor, at its own expense.
- B. Fill water must be within plus or minus 10 degrees of the ambient air and/or the pool structure at the time of filling. Extreme caution is urged if the temperature variance is greater than 10-degree F.
- C. Provide the necessary chemicals and to adjust and balance the water chemistry in the pools to the following levels:

pH	7.4 - 7.6
Calcium Hardness	200 - 400 PPM
Total Alkalinity	60 - 80 PPM
Langelier saturation index	-0.3 - +0.3
Total Dissolved Solids (TDS)	not to exceed 1,500 PPM

#### **1.13 START-UP CHEMICALS**

- A. The Contractor must maintain the chemical balance of the pool water (including the cost of chemicals required) until the pool and mechanical system(s) are fully operational and accepted by the Architect and the Owner.
- B. Provide the Owner with sufficient quantities of the necessary chemicals to maintain the pool operation after the owner begins using the pool.
  1. The Contractor is required to provide chemical quantities as shown on the drawings for the following chemicals:
    - a. Calcium Hypochlorite
    - b. Sodium Bisulfate
- C. Chemicals must be provided to the Owner must include those required by the chemical feed systems provided.

#### **1.14 RECORD DRAWINGS**

- A. Provide a complete set of record drawings of the renovated pool system. Record drawings must be a complete, stand-alone set. The Contractor is permitted to obtain original documents and copy them for this purpose only.

### **PART 2 - PRODUCTS**

#### **2.01 FILTRATION EQUIPMENT**

- A. The filter system must consist of high-rate pressure sand filter tanks as shown on the drawings. Every aspect and component of the filter system must be certified by the National Sanitation Foundation (NSF) and bear the certification mark. The filter must have an engraved metal data

plate permanently affixed on the face of the system that describes operational data and instructions and indicates startup date.

- B. It is the intent of these specifications to describe a filtration system complete in every respect with accessory items and supplied and warranted by one manufacturer.
- C. Horizontally Oriented Fiberglass Tank(s) (Leisure Pool, Hot Tub, and Competition Pool)
  - 1. The filter tanks must be horizontally oriented single cell fiberglass tanks, minimum 36 inches in diameter. The filter system must be listed as approved by the National Sanitation Foundation prior to bid date.
    - a. Basis of Design: Fiberglass filters must be the product of Stark/Pentair, Waterco, Neptune Benson, or approved equal provided they meet the specifications and layout. System design is based upon Neptune-Benson. Valves must be provided to backwash one filter at a time.
  - 2. Filter tanks must incorporate components and features as described in this section.
  - 3. Two (2) saddle style bases must be provided for tank support. Systems that incorporate stacked tanks must include similar bases and mounting saddles for the upper vessel. Tank supports and connections must be seismic rated to support the filter tank(s) for the appropriate seismic zone where the project is located. Access to the tank must be provided by a 14" x 18" manhole with two (2) curved yokes. Manhole seal must be complete with a one-piece 1/4" neoprene gasket and positioned so that internal pressure from the filter will augment the seal. No additional hardware or through bolts will be allowed.
  - 4. Each filter tank must be equipped with the necessary flanges and connections for the internal and external piping. Connections must be comprised of fiberglass flanges and schedule 80 PVC flanges.
  - 5. Tank connections 2 inches and smaller must be 150 lb. Type 316L stainless-steel threaded full couplings. Tank connections 3 inches and larger must be heavy steel bosses drilled and tapped on both sides to receive standard flanged fittings or Sch. 40 Type 316L stainless-steel nipples.
  - 6. The discharge from the automatic air release valve must be hard piped to waste. Each filter tank must have a means of releasing air. Each coupling or orifice must be provided with a slotted PVC sand retainer or stainless-steel strainer. An automatic air release system must be provided for each tank.
  - 7. The drain system must consist of a 3/4-inch 316L stainless-steel coupling mounted at the lowest point in the bottom head. This drain must be valved and piped to the nearest floor drain or backwash pit.
  - 8. Filter Piping - Internal
    - a. The lower internal distribution system must be a horizontal header/lateral arrangement. The header must be Schedule 80 PVC construction, capped on one end and flanged or threaded at the other end for field connection. Lateral connections must be spaced no more than 6 inches on centers and must be 1-1/2-inch FPT connections. Attachments to header must be solvent welded and thermo-welded to ensure integrity of connection.
    - b. Under drain system must be factory installed and constructed of extra heavy Schedule 80 high impact PVC. Multiple PVC main headers must be tapped and threaded to receive laterals.
    - c. Laterals must consist of 1-1/2-inch Schedule 80 PVC pipe with openings as required. Each lateral must be fabricated complete with socket cap on one end and male adapter on the other end. Both fittings must be solvent welded to the slotted pipe.

- Laterals must be designed and sized at the factory, so they are installed in the field and over the entire cross sections area of the filter.
- d. The upper distributor must consist of PVC piping Schedule 80 and/or deflector plate per manufacturer standard design.
  - e. Each filter must be supplied with a pressure equalizing upper internal distribution system consisting of a horizontal header/lateral arrangement. The header piping must be constructed of Schedule 80 PVC. The header/lateral piping and connections must be designed and sized to provide uniform distribution and unrestricted flow during the filtration and backwash cycles.
  - f. Upper laterals must be constructed of Schedule 80 PVC pipe with machine slotted openings or orifices. Machined slots or orifices must be clean, de-burred and free of obstructions that would not permit the free flow of water through the opening. Details of the lateral attachment to the header must be submitted for review and approval.
  - g. The lower and upper distribution systems must be properly supported and anchored. Hardware in wetted areas must be Type 316L stainless-steel or non-metallic. Tank interiors must be inspected prior to the media being placed in the filters.
9. Filter Piping - External (Face)
- a. External face piping must be Schedule 80 PVC pipe and fittings. Flanges must be located so as to allow for easy dismantling of face piping. Fittings must be solvent cemented.
  - b. Piping must be drilled and tapped where necessary to accommodate gauge tubing connectors.
  - c. Valves 3" and larger must be constructed with cast aluminum S12A alloy (as defined by ASTM B275) housing and fully coated with Rilsan on interior and exterior surfaces. Internal components include EPDM resilient lining, Rilsan coated ductile iron disc and 316L stainless-steel shaft. Valves must be rated for 150 psi bubble tight shutoff. Unless otherwise specified, nuts and bolts must be stainless-steel with stainless-steel washers and used when secured to PVC flanges. Systems incorporating solenoid, pneumatic, pressure amplified, hydraulic or multi-directional valves are not acceptable.
  - d. Standard accessory items must include sight glass rated for 50 psi with polycarbonate glass, remote mounted gauge panel with two 4½" diameter pressure gauges, ¼" petcocks, ¼" poly vent tubing with PVC compression adapters.
10. Backwash Control
- a. The filter manifold face piping must be designed to allow for one (1) filter tank to backwash at a time while the recirculation system is operating. A manual backwashing system must be provided with the filter system.
  - b. Manual Backwash System
    - 1) The manual backwash system must be equipped with a face piping configuration such that the operator must manually control and operate both the time and sequencing of the backwash cycle. Valving on the filter face piping must be a mechanical linkage device allowing the operator to simultaneously move two (2) valves at once. Mechanical linkage components must be PVC or Type 316L Stainless-steel.
11. Automatic Air Relief Valve
- a. A 1" valve must be provided to automatically and continuously release air in the filter. The valve must be fabricated of plastic with Buna-N seals. A plumbing kit must be

provided with two (2) PVC ball valves to allow manual air relief and isolation of the automatic valve. Valves fabricated of cast iron, bronze or stainless-steel valves will not be accepted.

12. Filter Media (Sand)

- a. Filter media must be a carefully selected grade of hard uniformly graded silica material. Media must be milled angular shaped particles of silica quartz. The filter sand must have a particle size between 0.45 mm and 0.55 mm and have a uniformity coefficient not to exceed 1.53. Specific gravity must not be less than 2.5 with a pH of 7.0.
- b. Media (sand) must be cleaned and free from clay or limestone deposits. The bottom layer of support media must be placed by hand to avoid damage to the under-drain system and leveled before the addition of the upper layer of filter media.
- c. Media must be delivered after approval by the manufacturer of the filter and stored in 100-pound bags for ease of handling and elimination of possible contamination.
- d. Media must be supplied by the filter manufacturer and approved by the filter manufacturer prior to shipping.

13. Support Media

- a. A gravel support media of a hard-coarse aggregate with a sub-angular grain shape with a particle size of 1/8" x 1/4" must be used on the inside of the bottom head to the elevation where the filter media commences. The specific gravity must not be less than 2.5. Support media must be placed by hand to avoid damage to the underdrain system and leveled before the addition of the upper layer of filter media. Concrete under fill is not recommended. Support gravel must be delivered and stored in 100-pound bags (approximately one cubic foot) for ease of handling and elimination of possible contamination. Media must be free from minerals which can precipitate onto pool surfaces.
- b. Sand must be a carefully selected grade of hard, uniformly graded silica material. Media must be naturally rounded particles of silica or milled angularly shaped particles of silica quartz. Sand must have a particle size between 0.45mm and 0.55 mm (#20). No more than 1.5% is allowed to pass through a #40 sieve (.0164"). Uniformity coefficient must not exceed 1.53. Specific gravity must be not less than 2.5. The filter must contain a minimum bed depth as recommended by the manufacturer. Systems which do not provide a minimum bed depth will not be accepted. Sand must be delivered and stored in 100-pound bags (approximately one cubic foot) for ease of handling and elimination of possible contamination. Media must be free from minerals which can precipitate onto pool surfaces.

D. Vertically Oriented Fiberglass Tank(s) (Tot Pool)

1. The filter tanks must be vertically oriented single cell fiberglass tanks. The filter system must be listed as approved by the National Sanitation Foundation for the filter rate specified prior to bid date.
  - a. Basis of Design: Fiberglass filters must be the product of Hayward, Waterco, Neptune Benson, or approved equal provided they meet the specifications and layout. Valves must be provided to backwash one filter at a time.
2. The system must be supplied completely by the manufacturer and must include internals, face piping and valves, sight glass, air relief connection and bottom drain connection with internal strainer.
3. The filter tank must be suitable for 50 psi working pressure and designed with a 4:1 safety factor.

4. A base must be provided for tank support. Tank supports and connections must be seismically rated to support the filter tank for the appropriate seismic zone where the project is located.
5. Access to the tank must be provided by a manhole. The manhole seal must be one-piece and positioned so that internal pressure from the filter will augment the seal.
6. Each filter tank must be equipped with the necessary flanges and connections for the internal and external piping. Connections must be comprised of fiberglass flanges and schedule 80 PVC flanges.
7. The discharge from the automatic air release valve must be hard piped to waste. Each filter tank must have a means of releasing air. Each coupling or orifice must be provided with a slotted PVC sand retainer or stainless-steel strainer.
8. The filter must be provided with a drain system mounted at the lowest point in the bottom head. This drain must be valved and piped to the nearest floor drain or backwash pit.
9. Filter Piping - Internal
  - a. The header must be Schedule 80 PVC construction, capped on one end and flanged or threaded at the other end for field connection. Lateral connections must be spaced no more than 6 inches on centers and must be 1-1/2-inch FPT connections.
  - b. Underdrain laterals must consist of schedule 80 PVC pipe. Machined openings must be designed to retain all media particles as small as 0.30 mm particle size.
  - c. Overdrain laterals must consist of schedule 80 PVC pipe. Overdrain laterals must be designed to provide uniform distribution and unrestricted flow during filter and backwash cycles.
  - d. Each filter must be supplied with a pressure equalizing upper internal distribution system consisting of a horizontal header/lateral arrangement. The header piping must be constructed of Schedule 80 PVC. The header/lateral piping and connections must be designed and sized to provide uniform distribution and unrestricted flow during the filtration and backwash cycles.
  - e. The lower and upper distribution systems must be properly supported and anchored. Hardware in wetted areas must be Type 316L stainless-steel or non-metallic. Tank interiors must be inspected prior to the media being placed in the filters.
10. Filter Piping - External (Face)
  - a. External face piping must be Schedule 80 PVC pipe and fittings. Flanges must be located so as to allow for easy dismantling of face piping. Fittings must be solvent cemented.
  - b. Piping must be drilled and tapped where necessary to accommodate gauge tubing connectors.
  - c. The valve body must be constructed of ABS with EPDM o-ring seal and Kynar spider gasket. 3" valves must have socket connections.
  - d. Standard accessory items must include sight glass rated for 50 psi with polycarbonate glass, remote mounted gauge panel with two 4½" diameter pressure gauges, ¼" petcocks, ¼" poly vent tubing with PVC compression adapters.
11. Backwash Control
  - a. The filter manifold face piping must be designed to allow for one (1) filter tank to backwash at a time while the recirculation system is operating.
  - b. Manual Backwash System

- 1) A mechanical linkage must connect two (2) valves in order to create simultaneous movement. Connecting pieces must vary with the size of face piping in order to operate with suitable mechanical advantage. All linkage parts must be T304L stainless steel.
- 2) Linkage must be designed so that filter and backwash cycles can be accomplished by repositioning two (2) pairs of valves. Each pair of valves must be operated as specified with lever, gear, or electric actuation.
- 3) All linkage components must be grit blasted to a 1-2 mil profile. All linkage components must be finish coated with 3-4 mils DFT of Type 316 pigmented stainless-steel paint.

12. Filter Media

- a. Filter media must be a carefully selected grade of hard uniformly graded silica material. Media must be milled angular shaped particles of silica quartz. The filter sand must have a particle size between 0.45 mm and 0.55 mm and have a uniformity coefficient not to exceed 1.53. Specific gravity must not be less than 2.5 with a pH of 7.0.
- b. Media (sand) must be cleaned and free from clay or limestone deposits. The bottom layer of support media must be placed by hand to avoid damage to the under-drain system and leveled before the addition of the upper layer of filter media.
- c. Media must be delivered after approval by the manufacturer of the filter and stored in 100-pound bags for ease of handling and elimination of possible contamination.
- d. Media must be supplied by the filter manufacturer and approved by the filter manufacturer prior to shipping.

13. Support Media

- a. A gravel support media of a hard-coarse aggregate with a sub-angular grain shape with a particle size of 1/8" x 1/4" must be used on the inside of the bottom head to the elevation where the filter media commences. The specific gravity must not be less than 2.5. Support media must be placed by hand to avoid damage to the underdrain system and leveled before the addition of the upper layer of filter media. Concrete under fill is not recommended. Support gravel must be delivered and stored in 100-pound bags (approximately one cubic foot) for ease of handling and elimination of possible contamination. Media must be free from minerals which can precipitate onto pool surfaces.
- b. Sand must be a carefully selected grade of hard, uniformly graded silica material. Media must be naturally rounded particles of silica or milled angularly shaped particles of silica quartz. Sand must have a particle size between 0.45mm and 0.55 mm (#20). No more than 1.5% is allowed to pass through a #40 sieve (.0164"). Uniformity coefficient must not exceed 1.53. Specific gravity must be not less than 2.5. The filter must contain a minimum bed depth as recommended by the manufacturer. Systems which do not provide a minimum bed depth will not be accepted. Sand must be delivered and stored in 100-pound bags (approximately one cubic foot) for ease of handling and elimination of possible contamination. Media must be free from minerals which can precipitate onto pool surfaces

**2.02 PIPING SYSTEMS**

A. General

1. Provide recirculating piping between the pool(s) and the pool mechanical room, fill funnel and all interconnecting piping to and from the chemical feed systems and chemical controller.

2. Provide necessary pipe supports and support systems required to support associated piping and valves.
3. Provide other tubing, conduit or piping associated with equipment specified herein. Coordinate with other trades.

B. Pipes

1. Pipe routing as shown and detailed on the contract drawings is diagrammatic only and is not intended to show minor details or exact locations of piping systems. Installation is required and must be adjusted to accommodate interference and adjustments anticipated and encountered. Pipe sizes on plans refer to the nominal inside diameter of the pipe.
2. PVC swimming pool piping must be NSF approved and conform to the requirements of ASTM D-1785.
3. PVC pipes must be the product of one manufacturer. Approved manufacturers of PVC piping are Eslon, Harvel, and Chemtrol or approved equal.
4. The swimming pool piping must be Schedule 80 PVC.
5. PVC fittings must be the product of one manufacturer. Molded fittings must be manufactured by Ipex, Chemtrol, Harvel, Spears, and Lasco/Westlake or acceptable substitutes. Fabricated fittings must be manufactured by Harrison Machine, Spears, or an acceptable substitute.
6. Chemical feed lines from chemical feeders to recirculation piping must be Schedule 80 PVC piping. Piping must be hard piped into the recirculation piping via tee or saddle per the drawings. Required valves must be of PVC construction.
7. Flanged plumbing connection hardware must be stainless-steel.
8. Materials must be installed by workmen thoroughly skilled in their trades and work must present a neat and mechanical appearance when complete. At no additional expense to the Owner, replace or correct work not judged acceptable by the Architect, Engineer, or Owner's representation.
9. No installation allowed that will provide a cross-connection or interconnection between a distributing supply for drinking purposes and the swimming pool, or between the pool and a sanitary or storm water sewer system that will permit a backflow of water into the pool water system.
10. Piping must be hydrostatically (water) pressure tested for leaks to guarantee water tightness. Pneumatic (air) pressure test is not allowed.
11. Mechanical equipment must be connected into the recirculation piping system must be connected utilizing flanged or union connections.
12. Concentric reducers must be fiberglass by MerMade Filter, Inc., or equivalent reducers of schedule 80 PVC construction.

C. Pipe Hangers and Supports

1. Manufacturer
  - a. Subject to compliance with these specifications, pipe hanger and support systems must be manufactured by Cooper B-line (basis of design), Inc, TOLCO, and Anvil International or approved equal.
2. Hangers
  - a. Pipes 2 inches and smaller
    - 1) Adjustable steel clevis hanger, B-Line models B3100 or B3104.

- 2) Adjustable steel swivel ring (band type) hanger, B-Line model B3170.
    - b. Pipes 2-1/2 inches and larger
      - 1) Adjustable steel clevis hanger, B-Line model B3100.
      - 2) Adjustable steel yoke pipe roll, B-Line model B3114.
  3. Multiple or Trapeze Hangers
    - a. Trapeze hangers must be constructed from 12-gauge roll formed ASTM A1011 SS, Grade 33 structural steel channel, 1-5/8 by 1-5/8-inch minimum, B-Line B22 strut or stronger as required.
    - b. Mount pipes to trapeze with 2-piece pipe straps sized for outside diameter of pipe, B-Line B-2000 series.
  4. Wall Supports
    - a. Pipes 2-1/2 inches and smaller
      - 1) Steel offset "J" hook hanger, B-Line model B3600.
    - b. Pipes 3 inches and larger
      - 1) Welded strut bracket and pipe straps, B-Line models B3064 and B2000 series.
      - 2) Welded steel bracket B-Line model B3066 or B3067 with roller chair or adjustable steel yoke pipe roll. B-Line model B3120 or B3110.
  5. Floor Supports
    - a. Electroplated carbon steel adjustable pipe saddle and nipple attached to steel base stand sized for pipe elevation. B-Line model B3092 and B3088T or B3090 and B8088. Pipe saddle must be screwed or welded to an appropriate base stand.
  6. Vertical Supports
    - a. Steel riser clamp sized to outside diameter of pipe, B-Line model B3373.
  7. Plastic Pipe Supports
    - a. V-Bottom clevis hangers with galvanized 18-gauge continuous support channel, B-Line models B3106 and B3106V, to form a continuous support system for plastic pipes smaller than 1 inch or flexible tubing.
    - b. A vented and sloped continuous PVC Schedule 40 pipe no smaller than 1-1/2 inch outside diameter will be used to route flexible tubing with the appropriate pipe supports.
  8. Supplementary Structural Supports - Design and fabricate supports using structural quality steel bolted framing materials. Channels must be roll formed, 12-gauge ASTM A1011 SS Grade 33 steel, 1-5/8 inch or greater as required by loading conditions. Submit design for pipe tunnels, pipe galleries etc. for approval. Use clamps and fittings designed for use with the strut system.
- D. Hanger Attachments
1. Upper Attachments
    - a. Beam Clamps
      - 1) Beam clamps must be used where piping must be suspended from building steel. Clamp type must be selected on the basis of load supported and load configuration.

- 2) C-Clamps must be locknuts and cup point set screws similar to B-Line model B351L or B3036L. Top flange c-clamps must be used when attaching a hanger rod to the flange of structural steel, B-Line model B3034 or B3033 or approved equal. Refer to manufacturer's recommendations for set screw torque. Retaining straps must be used to maintain the clamp position on the beam where required.
- 3) Center load beam clamps must be used where specified. The steel clamps must be B-Line models B3050 or B3055. Forged steel beam clamps with cross bolt must be B-Line B3291-B3297 series or approved equal as required to fit beams.

b. Concrete Inserts

- 1) Cast in place spot concrete inserts must be used applicable, either steel or malleable iron body, B-line B2500 or B3014 or approved equal. Spot inserts must allow for lateral adjustment and have means for attachment to forms. Select inserts to suit threaded hanger rods sizes, B-line models N2500 or B3014N series.
- 2) Continuous concrete inserts must be used where applicable. Channels must be 12 gauge, ASTM A1011 Grade 33 structural quality carbon steel, complete with Styrofoam inserts and end caps with nail holes for attachment to forms. The continuous concrete insert must have a load rating of 2,000 lbs/ft. in concrete, B-Line models B22I, 32I, or 52I or approved equal. Select channel nuts suitable for strut and rod sizes.

E. Hanger Accessories

1. Hanger rods must be threaded on both ends or continuously threaded rods of circular cross section. Use adjustable lock nuts at upper attachments and hangers. No wire, chain, or perforated straps are allowed.

F. Hanger Finish

1. Indoor Finishes
  - a. Hangers must be zinc plated in accordance with ASTM B633 or must have an electro-deposited green epoxy finish.
  - b. Strut channels must be pre-galvanized in accordance with ASTM A653 SS Grade 33 G90 or must have an electro-deposited green epoxy finish.
  - c. Zinc Plated hardware is not acceptable for use in chemical rooms.

G. Valves

1. Valves 3 inches and larger must be butterfly type valves, with PVC body, 150# SWP with stainless-steel shaft, PVC or polypropylene disc and replaceable resilient seat bonded to a rigid shaft and guaranteed for bubble tight shutoff from 27-inch vacuum to 150 PSI. Extended neck 2 inches beyond flanges for insulated piping must be provided with handle for manual operation. Valve components must be suitable for swimming pool chlorinated water service. Butterfly valves must be Georg Fischer Type 567, Asahi/America Type SP Pool-Pro, Chemtrol Model-B, Simtech VP series, Colonial Valve 411 Series, or approved equal.
2. Valves smaller than 3 inches must be PVC true union ball valves, full port, three-piece construction, blowout-proof stem, Viton seal with socket end connectors.
3. Butterfly type valves 8 inches and larger must be fitted with a watertight gear operator.
4. Valves located 7 feet or greater off the floor must be fitted with a chain operator.

5. Valve hardware must be 316L stainless-steel and meet ANSI hardware installation guidelines.

H. Pipe and Valve Identification

1. New exposed pool piping must be equipped with color coded flow directional arrows at intervals per local swimming pool health code. Verify that pool piping identification is in accordance with governing health regulations.
2. New valves must be identified with minimum 1-1/2-inch diameter plastic laminate engraved tags with minimum 1/2-inch-high numbers. Tags must be fastened to valves with a nylon attachment (zip tie). Valves must be described as to their function and referenced in the operating instruction manual and wall mounted piping diagram that must be prepared.

**2.03 CHEMICAL TREATMENT SYSTEMS**

A. Calcium Hypochlorite (Chlorine Tablets)

1. Shop drawings complete with a piping diagram depicting the location in which the dry chlorination feeder is connected to the system must be provided and approved prior to installation. Installation of the system must be as specified in the manufacturer's directions with no exceptions taken.
2. A factory-authorized representative must provide training to the owner and the training must be video recorded.
3. Accu-Tab PowerBase
  - a. General Description
    - 1) The system must be designed to feed low concentrations of calcium hypochlorite in solution intermittently or continuously as required for pool applications. The system must be a single pre-assembled, package unit with a welded aluminum frame consisting of chlorinator, electrical box, centrifugal pump, and solution tank for ease of installation and operation. The system must be the Accu-Tab PowerBase. Only Accu-Tab Blue SI calcium hypochlorite tablets must be used, the patented blue colorant added for safety (to help prevent accidental mixing with other chemicals).
    - 2) The system must use an NSF Standard 50 listed erosion feeder and tablet combination and must be capable of meeting the requirements of the Health Department having jurisdiction over the installation.
  - b. System Features
    - 1) A maximum chlorine solution level of 0.05% (500 ppm) must be maintained to prevent calcification in system components. Systems producing chlorine concentrations higher than 0.05% are not acceptable.
    - 2) Delivery must be by erosion feed technology to control accurate and consistent concentration limits in the chlorine treatment solution. Soaking type, spray, and/or vortex technology systems are not acceptable.
    - 3) The chlorinator must automatically and continuously feed a limited quantity of chlorine in solution as needed; when the system is not running, no more chlorine than that amount which can be fed in one minute or less must be left in the tank to prevent dilution. Batch systems preparing excess quantities of solution for delivery over an extended period are not acceptable.
    - 4) A centrifugal pump wired to the system electrical box must feed freshly mixed chlorine treatment solution only as required for maximum efficiency. Batch

systems requiring the use of a metering pump or pumps to feed pre-prepared standing solution are not acceptable.

- 5) Piping in the chlorinator unit must be Schedule 40 PVC. Systems with flexible tubing are not acceptable.

c. System Components

- 1) Accu-Tab PowerBase chlorinators are designed exclusively for Accu-Tab Blue SI calcium hypochlorite tablets. Tablets are placed on a sieve plate inside the chlorinator; as water flows across the sieve plate, the tablets erode at a rate proportional to the flow rate.
- 2) Inlet Water Supply Connection.
  - a) Model 1030: 1.5" (water supply of 10 GPM required)
- 3) Inlet Water Filter: A filter to protect chlorinator components from start-up debris and sand from broken filter laterals.
- 4) Flow Meter:
  - a) A rotameter flow meter, measuring the flow of the water-eroding stream to the chlorinator.
- 5) Solution Tank: Made of PVC.
- 6) Capacities:
  - a) Model 1030: 7 gallons
- 7) Primary Solution Tank Level Control: Made from Schedule 80 PVC and 316L stainless-steel. The float valve opens to maintain the pump rate as it is manually throttled.
- 8) Overflow Protection: Two (2) level switches in the upper portion of the solution tank will run the pump from high to lower level to prevent system overflow.
- 9) Solution Delivery Pump: Delivers chlorinated solution to the return line. A single-stage centrifugal pump is provided for systems with pressures up to 20 PSIG.
- 10) Primary Backflow Prevention: A PVC swing check valve prevents reverse flow of water into the system.
- 11) Discharge Control Valve (manual): PVC gate valve allows operator to adjust flow of solution to the system.
- 12) Outlet Connection:
  - a) Model 1030: 1"
- 13) Aluminum Frame: Type 6061-T.
- 14) NEMA 4X Electrical Enclosure

B. pH Buffering System (Dry Acid)

1. Shop drawings complete with a piping diagram depicting the location in which the dry acid feeder is connected to the system must be provided and approved prior to installation. Installation of the system must be as specified in the manufacturer's directions with no exceptions taken.
2. Acid Rite
  - a. General Description

- 1) The system must be designed to erode Acid-Rite tablets, creating an acid solution, and feeding the solution intermittently or continuously as required for pool applications. The system must be a single pre-assembled, package unit with a welded aluminum frame consisting of an Acid-Rite feeder, electrical box, centrifugal pump, and balance tank for ease of installation and operation. The system must be the Acid-Rite pH Adjustment System by Axiall, a Westlake Company. Only Acid-Rite Tablets by Axiall must be used with a red colorant added for safety (to help prevent accidental mixing with other chemicals).
  - 2) The system must use an NSF Standard 50 listed erosion feeder and tablet combination and must be capable of meeting the requirements of the Health Department having jurisdiction over the installation.
- b. System Features
- 1) Delivery must be by erosion feed technology for accurate control of acid addition. Soaking type, spray, and/or vortex technology systems are not acceptable.
  - 2) The acid feed system must automatically and continuously feed a limited quantity of acid solution as needed. When the system is not running, no more acid solution than that amount which can be fed in 2 minutes or less must be left in the tank to prevent dilution. Batch systems preparing excess quantities of solution for delivery over an extended period are not acceptable.
  - 3) A centrifugal pump wired to the system electrical box must feed freshly mixed acid solution only as required for maximum efficiency. Batch systems requiring the use of a metering pump or pumps to feed pre-prepared standing solution are not acceptable.
  - 4) Piping in the acid feed system must be Schedule 80 PVC. Systems with flexible tubing are not acceptable.
- c. System Components
- 1) Acid Feeder: Acid-Rite feeders by Axiall are designed exclusively for Acid-Rite tablets by Axiall. Tablets are placed on a plate inside the feeder; as water flows across the plate, the tablets erode at a rate proportional to the flow rate. The lid color must be red, matching the pail lid color to avoid mixing chemicals.
  - 2) Inlet Filter: A filter is included to prevent debris from entering the float valve.
  - 3) Inlet Water Supply Connection: 1" Socket (water supply of 10 GPM required).
  - 4) Solution Tank Capacity:
    - a) Model 450: 6 gallons
  - 5) Primary Solution Tank Level Control: Made from Schedule 80 PVC and 316L stainless-steel, this 1" float valve meters the flow through the feed system. The float valve opens or closes to maintain the pump rate as it is manually throttled.
  - 6) Solution Delivery Pump: Delivers acid solution to the aquatic system return line. A single-stage centrifugal pump is provided for systems with pressures up to 20 PSIG.
  - 7) Solution Injection Pump Air Bleed: Used to prime the pump at start-up.
  - 8) Flow Meter: A flow meter, measuring the flow of the water-dissolving stream through the feed system.

- 9) Primary Backflow Prevention: A PVC check valve prevents reverse flow of water into the system.
- 10) Discharge Flow Control Valve (manual): PVC gate valve allows operator to adjust flow of solution to the pool system.
- 11) Overflow Port: A 1" FPT port is located on the back side of the feeder solution tank.
- 12) Stacking Cartridge:
  - a) Model 450: Utilizes a stacking cartridge that allows 1-7 stacks of tables to permit control of lower delivery rates.
- 13) Outlet Connection: 1"
- 14) NEMA 4x Electrical Enclosure
- 15) Aluminum Frame: Type 6061-T.

C. Electronic Flocculation System

1. The Clear-Flow Electronic Flocculation system must be provided and installed on the recirculation piping for the swimming pools and hot tub. The Clear-Flow system must be a non-chemical water treatment system designed to operate as an electronic flocculant in recreational water systems. When implemented into the system, the Clear-Flow system must work to agglomerate both organic and mineral particulate resulting in filtration enhancement on all types of filtration systems. This filtration enhancement must allow for a reduction in backwashing frequency - saving water, chemicals, and energy.
2. The Clear-Flow system must be UL listed and certified to NSF/ANSI Standard 50 and documentation of such certification must be provided by the manufacturer with each system.
3. When used in a recreational water application, the Clear-Flow system must work as an electronic flocculant. By generating and propagating a low-frequency treatment signal throughout the entire plumbing system, the technology must produce an ongoing flocculation effect which will aid in a reduction in turbidity and improved clarity.
4. The Clear-Flow system's ongoing flocculation effect must enhance filtration efficiency. The flocculation effect must create larger particles allowing for a reduction in both frequency and duration of backwashing.
5. Equipment
  - a. The following components are contained in a standard Clear-Flow kit and must be provided for each system:
    - 1) ABS or SS enclosure with 3 glands (2 for signal leads and 1 for power supply)
    - 2) Signal cables complete with mounting tags (Temp. rating -40°F to +140°F) (Qty. 2)
    - 3) Stainless steel hose clamps (Qty. 4)
    - 4) Gland plug (Qty. 1)
    - 5) 2A / 250 VAC UL-listed slow blow fuse (Qty. 1)
    - 6) 4mm Allen wrench (for grub screw) (Qty. 1)
6. Clear-Flow electronic flocculation system models must be the following:
  - a. For pipes up to 3": Model # CF-300C
  - b. For 4" pipes: Model # CF-400

- c. For 6" pipes: Model # CF-600
  - d. For 8" pipes: Model # CF-800
  - e. For 10" pipes: Model # CF-1000
7. Power Requirements:
- a. Input Voltage: 100–240 VAC
  - b. Input Frequency: 50 - 60 Hz
  - c. Power Rating: 4W for CF-300C, 5.4W for all other models
  - d. Internal Fuse Rating: 2A / 250VAC UL-Listed slow-blow
  - e. Temperature Range: -40°F to +140°F
  - f. The electrical supply must be properly grounded, or the system will not work. Hard wiring is preferred to avoid accidentally unplugging the unit.
  - g. All safety-critical components must conform to relevant CE/IEC/UL 60950. E235235. Terminals, wires, fuse, on/off switch, AC/DC PSU. PSU must be Class II protected.
  - h. Armored 2 Core Cable:
    - 1) Spec. BC 6883; 1999
    - 2) IEC 600332 –3—22 Category A
    - 3) Temperature rating - 22°F to +140°F
    - 4) ISO 9001 – 2008 Approved
8. Installation
- a. To ensure proper start-up of equipment the Contractor must consult a Clear-Flow representative.
  - b. Optimal results are achieved if the Clear-Flow system is connected to a grounded power outlet (100-240 VAC, 50-60 Hz, 4-amp) that shares the same ground as the recirculation system the unit is being installed on.
  - c. The Clear-Flow system must come with two identical signal cables. One is intended as the "T" (transmit) signal connection, the other is intended as the "A" (antenna) signal connection. The "T" signal tag must be installed downstream from the pump and before the filter. It is preferred that the "T" signal tag is mounted on a metal reducer or stainless-steel spool piece downstream of the pump. Alternative installation points for the "T" signal tag can be to mount it on a metal valve, the downstream flange of the pump (if metallic), or a stainless-steel spool piece that would provide a metal-to-water path for the treatment signal to propagate into and throughout the pool's recirculation system. The "A" tag must be mounted on a metal structure that is electrically connected to the system loop, which may include but is not limited to a grounded filter, nearby structure, or ground rod.
  - d. The Contractor must provide a stainless-steel spool piece matching the main recirculation header pipe size installed between flanges downstream of the recirculation pump(s) and upstream of the filters to facilitate installation of the "T" signal tag per manufacturer requirements. Coating must be 3M Scotchkote 134 fusion bonded epoxy, or approved equivalent on the complete interior of fitting.
  - e. The maximum cable run length from the control cabinet (typically wall mounted) to the "T" signal tag installed on the pool recirculation pipe must be 33 feet. Installation locations must be coordinated to meet this parameter.

9. The Clear-Flow system unit must be rated for -40° F + 140° F ambient operation. The unit must have no ventilation requirements and be able to be used indoors and outdoors.
10. After identifying the proper installation location for the “T” tag, the Contractor must prepare the point for strong electrical contact with the tag. The Contractor must remove any epoxy or enamel coating which may inhibit a strong connection. The Contractor to make output connections per wiring schematic. Connect “T” and “A” connections into the labeled terminals inside the enclosure.
11. The Contractor must confirm Clear-Flow system is functioning properly and operating under the following conditions. After powering on the unit, consult the LCD screen to determine the frequency and amperage output.
  - a. The optimal frequency range is between 100-350 kHz.
  - b. Optimal amperage is between 1 and 5 amps.
  - c. If frequency and amperage are outside of these ranges, the Contractor must adjust capacitor switches on the upper right side inside the enclosure.
  - d. If current amperage is not achievable under 5 amps after making capacitor adjustments, the Contractor must disconnect “A” tag from inside the terminal block and repeat adjustment of capacitors.
  - e. If these steps do not result in an optimal sine wave within the recommended frequency and amperage, the Contractor must consult a Clear-Flow Representative.
  - f. As an additional means of signal verification, an oscilloscope can be used. By touching the oscilloscope probe onto the pipe near where the “T” tag is connected, signal strength and frequency can be measured. A clean, declining sine wave with minimal harmonics should be observed.
12. The Contractor must cut excess signal cable, but not to less than 10 feet (3 meters) in length. The Contractor must not coil power cord or signal cables; doing so will interfere with signal operation.
13. The Clear-Flow system must be powered on/off via a switch on the enclosure.
14. Replacement fuses must be UL-listed.
15. The complete installation must be by the manufacturer’s installation instructions and certified on-site for proper operation by the manufacturer’s representative for each system installation.
16. The Clear-Flow system requires that the electrical supply be properly grounded. The Contractor must follow Institute of Electrical and Electronics Engineers (IEEE) standards ensuring a ground resistance of 5 ohms or less.

#### **2.04 FLOW METERS**

- A. Impact flow meter must be provided as indicated on the drawings. Impact flow meter must be a pilot, impact ball, variable area type with one piece, impact resistant machined acrylic plastic body. GPM scale must be permanently etched or imprinted on the meter. Flow rate indicator must be of stainless-steel material. The scale range must be appropriate for a specific flow rate. Pipe size to accommodate backwash rate. The backwash piping flow meter must be BLUE-WHITE series F-300 or approved equal.

### **PART 3 - EXECUTION**

#### **3.01 EXISTING CONDITIONS, INSPECTION AND PREPARATION**

- A. Carefully examine the contract documents for requirements that affect the work of this section. Prior to starting work, notify the Architect of defects requiring correction. Do not start work until conditions are satisfactory.
- B. Verify that work by others, related to this section, has been completed. This includes earthwork, concrete work, and mechanical, electrical, and plumbing connections.
- C. Protect materials and work completed by others from damage while completing the work in this section.

#### **3.02 FIELD MEASUREMENTS**

- A. Verify benchmark and pool location prior to layout.
- B. If field measurements differ from the construction drawing dimensions, notification must be given to the Architect prior to proceeding with work.

#### **3.03 PIPING INSTALLATION**

- A. General
  - 1. Provide and erect, according to the best practices of the trade, piping shown on the drawings and required for the complete installation of these systems. The piping shown on the drawings must be considered as diagrammatic in indicating the general run and connections and may or may not in parts be shown in its true position. The piping may have to be offset, lowered, or raised as required or as directed at the site. This does not relieve responsibility for the proper erection of the systems or piping in every respect suitable for the work intended as described in the specifications and approved by the Architect. In the erection of piping, it must be properly supported, and proper provisions must be made for expansion, contraction and anchoring of piping. Piping must be cut accurately for fabrication to measurements established at the construction site. Pipe must be worked into place without springing and/or forcing, properly clearing windows, doors, and other openings and equipment. Cutting or other weakening of the building structure to facilitate installation will not be permitted. Pipes must have burrs and/or cutting slag removed by reaming or other cleaning methods in strict accordance with the manufacturer's instructions. Changes in direction must be made with fittings. Open ends of pipes and equipment must be properly capped or plugged to keep dirt and other foreign materials out of the systems. Plugs of rags, wool, cotton waste or similar materials will not be used in plugging. Piping must be arranged so as not to interfere with removal and maintenance of equipment, filters, or devices, and so as not to block access to manholes, access openings, etc. Flanges or unions applicable for the type of piping specified must be provided in the piping at connections to items of equipment. Piping must be installed to ensure noiseless circulation. Valves and specialties must be so placed to permit easy operation and access.
- B. Pipe Hangers and Supports
  - 1. Pipes must be adequately supported by pipe hangers and supports as specified.
  - 2. Horizontal PVC Schedule 80 piping must be supported in accordance with the manufacturer's recommendations for fluid temperature not exceeding 120-degree F and as listed below:

Nominal Pipe Size	Hanger Support Spacing	Minimum Rod Size for Single Rod Hanger
1-1/4" and less	5'-0"	3/8"
1-1/2" to 3"	6'-0"	1/2"
4" to 6"	8'-0"	5/8"

8" to 12"	10'-0"	7/8"
Greater than 12"	12'-0"	1"

3. Round rods supporting the pipe hangers must be of the following dimensions:

Nominal Pipe Size	Rod Diameter
1/2" to 2" pipe	-3/8" rod
2-1/2" to 3" pipe	-1/2" rod
4" to 5" pipe	-5/8" rod
6" pipe	-3/4" rod

4. Hanger rods must be galvanized steel. Provide for controlling level and slope by turn buckles or other approved means of adjustment and incorporate lock nuts.
  5. Provide means of preventing dissimilar metal contact such as plastic-coated hangers, copper colored epoxy paint, or non-adhesive isolation tape.
  6. Provide hangers to provide a minimum of 1-inch space between finished covering and adjacent work.
  7. Place a hanger within 12 inches of each horizontal elbow.
  8. Support vertical piping independently of connected horizontal piping. Support vertical pipes at every floor. Wherever possible, locate riser clamps directly below pipe couplings or shear lugs.
  9. Where several pipes can be installed in parallel and at the same elevation, provide trapeze hangers as specified. Trapeze hangers must be spaced according to the smallest pipe size or provide intermediate supports according to the support spacing schedules. Provide heavier members as required for the load supported for the entire span distance. Hanger rods must be as specified above and properly sized for the load supported, but not less than 5/8 inches diameter.
  10. Piping must be rigidly supported from the building structure by means of hanger assemblies properly selected and sized for the application in accordance with the manufacturer's recommendations and specifications. Do not support piping from other pipes, ductwork or other equipment that is not building structure. Do not modify the building structure for hanger installation.
  11. Attachment of piping hangers to the building structure must be provided in a manner approved by the Architect. Provide concrete inserts installed by others in the building construction at the time the concrete is poured, and hangers must be attached to these inserts.
  12. The use of pipe hooks, chains, or perforated iron for pipe hanger supports will not be permitted.
  13. A design for piping in a service tunnel, if required, supported by a structure must be submitted for approval. The structure must be non-corrodible and must be of a size and configuration to rigidly support the piping as shown in the plans at a minimum spacing as shown below.
- C. Concrete Inserts
1. Provide inserts for suspending hangers from reinforced concrete slabs and sides of reinforced concrete beams.
  2. Where concrete slabs form finished ceilings, inserts must be flush with the slab surface.
  3. Provide hook rods to concrete reinforcement section for inserts carrying pipe over 4 inches.
- D. Flushing, Draining and Cleaning Pipe Systems

1. Flush out water systems with water before placing them in operation. Other systems must be cleaned by using compressed air or nitrogen. After systems are in operation and during the test period, strainer screens must be removed and thoroughly cleaned.

E. Testing

1. Piping installation and pressure testing must be performed by the Contractor and reviewed by the Owner or a designated representative of the Owner. A minimum one (1) week notice must be provided prior to review. Results must be submitted to the Architect. Pictures with time stamps for each section of piping must be included with testing report(s) and be submitted within one (1) week of the pressure test(s).
2. Newly installed pool piping must be capped and hydraulically pressure tested with water to a pressure of not less than 50 PSI for a period of no less than two (2) hours. Pressure testing must be conducted in accordance with ASTM D2774. The temperature of the water used for the test must be between 40°F and 90°F.
3. Pneumatic testing (air) of any pool piping will not be accepted.

### **3.04 EQUIPMENT AND SYSTEMS INSTALLATION**

- A. Provide and assemble equipment, special parts and accessories as shown on pool drawings, specifications, and shop drawings of the equipment suppliers.
- B. Provide anchors and inserts properly imbedded including fittings, inserts and structure sleeves and required anchorage as shown on the plans and as indicated in this section of the specifications. Equipment must be set true and plumb, using factory jigs where available.
- C. Provide templates for equipment anchors. Provide anchor bolts of the size and spacing as required by the equipment manufacturer. Anchor bolts must be stainless-steel Type 316L and of a length capable of adequate anchorage.
- D. Provide equipment and systems in accordance with manufacturer's directions. Equipment must be assembled and in place for final observation.
- E. Items necessary to complete this section are shown on the plans or described in the specifications including items that may be purchased by the Owner. Items are detailed and specified as a guide for dimensional purposes. Make provisions accordingly and submit shop drawings and submittals based on that data.

### **3.05 START-UP AND INSTRUCTION**

- A. Supply the services of an experienced swimming pool operator/instructor for a period of not less than one day (total 8 hours) after the pool equipment has been placed in operation. During this period, the Owner's representatives who will be operating the pool(s) must be thoroughly instructed on the operation of the new equipment. Deliver two (2) complete sets of operating and maintenance instructions for the swimming pool equipment. Prior to leaving the job, obtain written certification from the designated Owner's representative acknowledging that the instruction period has been completed and necessary operating information provided.

**END OF SECTION**

## **PART 1 - GENERAL**

### **1.01 RELATED DOCUMENTS**

- A. Drawings and general provisions of the Contract, including General and Supplementary Conditions and Division 01 Specification Sections, apply to this Section.

### **1.02 SUMMARY**

- A. Section Includes:
  - 1. Demolition and removal of selected pool materials and equipment.
  - 2. Salvage of existing items to be reused or recycled.
  - 3. Protection of surrounding areas and equipment.
- B. Related Requirements:
  - 1. Division 1 Section "Temporary Facilities and Controls" for temporary construction and environmental-protection measures for selective demolition operations.
- C. Related work specified in other sections:
  - 1. Section 131100 - Swimming Pools

### **1.03 DEFINITIONS**

- A. Remove: Detach and remove items from the pool/equipment room and legally dispose of them off-site unless indicated to be removed and salvaged or removed and reinstalled.
- B. Remove and Store: Detach and store existing swimming pool items intended for reinstallation and/or reuse.

### **1.04 MATERIALS OWNERSHIP**

- A. Unless otherwise indicated, demolition waste becomes property of the Contractor.

### **1.05 SUBMITTALS**

- A. Proposed Protection Measures: Submit plan and report that indicates the measures proposed for protecting individuals and property for dust control and for noise control. Indicate proposed locations and construction of barriers, if necessary.

### **1.06 CLOSEOUT SUBMITTALS**

- A. Inventory: Submit a list of items that have been removed and salvaged.
- B. Landfill Records: Indicate receipt and acceptance of hazardous wastes by a landfill facility licensed to accept hazardous wastes.

### **1.07 FIELD CONDITIONS**

- A. Owner will occupy portions of building immediately adjacent to selective demolition area. Conduct selective demolition so Owner's operations will not be disrupted.
- B. Conditions existing at time of inspection for bidding purpose will be maintained by Owner as far as practical.
- C. Notify Architect of discrepancies between existing conditions and Drawings before proceeding with selective demolition.

- D. Hazardous Materials
  - 1. If suspected hazardous materials are encountered, do not disturb; immediately notify Architect and Owners Representative.
- E. Storage or sale of removed items or materials on-site is not permitted.
- F. Utility Service: Maintain existing utilities indicated to remain in service and protect them against damage during selective demolition operations.
  - 1. Maintain fire-protection facilities in service during selective demolition operations.

## **PART 2 - PRODUCTS**

### **2.01 PERFORMANCE REQUIREMENTS**

- A. Regulatory Requirements: Comply with governing EPA notification regulations before beginning selective demolition. Comply with hauling and disposal regulations of authorities having jurisdiction.
- B. Standards: Comply with OSHA Standards 29 CFR Part 1926 & 1910.
- C. Standards: Comply with ANSI/ASSE A10.6 and NFPA 241.

## **PART 3 - EXECUTION**

### **3.01 EXAMINATION**

- A. Verify that all piping to remain has been plugged before starting selective demolition operations. All piping and pool equipment to remain must fully drained immediately following the draining of the pool until the pool is ready to be refilled and started up for final system commissioning.
- B. Review record documents of existing construction provided by Owners Representative. Owners Representative does not guarantee that existing conditions are same as those indicated in record documents.
- C. Survey existing conditions and correlate with requirements indicated to determine extent of selective demolition required.
- D. When unanticipated mechanical, electrical, or structural elements that conflict with intended function or design are encountered, investigate and measure the nature and extent of conflict. Promptly submit a written report to Architect.
- E. Survey of Existing Conditions: Record existing conditions by use of preconstruction photographs.
- F. Notify Owner on completion of selective demolition and obtain documentation verifying that existing surfaces have been inspected and accepted.

### **3.02 PREPARATION**

- A. Site Access and Temporary Controls: Conduct selective demolition and debris-removal operations to ensure minimum interference with roads, streets, walks, walkways, and other adjacent occupied and used facilities.
- B. Temporary Facilities: Provide temporary barricades and other protection required to prevent injury to people and damage to adjacent buildings and facilities to remain.
  - 1. Provide protection to ensure safe passage of people around selective demolition area and to and from occupied portions of building.
  - 2. Protect walls, ceilings, floors, and other existing finish work that are to remain or that are exposed during selective demolition operations.

3. Cover and protect furniture, furnishings, and equipment that have not been removed.
4. Comply with requirements for temporary enclosures and dust control.

### **3.03 DISPOSAL OF DEMOLISHED MATERIALS**

- A. General: Except for items or materials indicated to be recycled, reused, salvaged, reinstalled, or otherwise indicated to remain Owner's property, remove demolished materials from Project site and legally dispose of them in an EPA-approved landfill.
  1. Protect all finished surfaces during the demolition process.
  2. Do not allow demolished materials to accumulate on-site.
  3. Remove and transport debris in a manner that will prevent spillage on adjacent surfaces and areas.
- B. Disposal: Transport demolished materials off Owner's property and legally dispose of them.

### **3.04 CLEANING**

- A. Clean adjacent structures and improvements including but not limited to structural spaces of dust, dirt, and debris caused by selective demolition operations. Return adjacent areas to condition existing before selective demolition operations began.

**END OF SECTION**

**Part 1            General**

**1.1                DESCRIPTION**

- .1        This Section covers items common to Sections of Divisions 26, This section supplements requirements of Division 1.
- .2        For the proper execution of work, cooperate with other trades and contracts as needed.
- .3        To avoid installation conflicts, thoroughly examine the complete set of contract documents. Resolve conflicts with Consultant prior to installation.
- .4        Prior to installation of feeders to equipment requiring electrical connections, examine the manufacturer's shop drawings, wiring diagrams, product data and installation instructions. Verify that the electrical characteristics detailed in the contract documents are consistent with the electrical characteristics of the actual equipment being installed. When inconsistencies occur request clarification from Consultant.
- .5        Examine the entire set of contract documents to avoid conflicts with other systems. Determine exact route and installation of electrical wiring and equipment with conditions of construction.
- .6        Should the electrical documents indicate a condition conflicting with the governing codes or regulations, refrain from installing that portion of the work until clarified by Consultant.
- .7        Definitions:
  - .1        Provide - To furnish and install complete and ready for intended use.
  - .2        Furnish - Supply and deliver to project site, ready for unpacking, assembly, and installation.
  - .3        Install - Includes unloading, unpacking, assembling, erecting, installation, applying, finishing, protecting, cleaning and similar operation at the project site to complete items of work furnished.
- .8        All correspondence and documents shall be submitted in English.
- .9        The entire bid package is considered related to all disciplines and shall be examined prior to bid and followed throughout construction and thereafter. Related sections listed hereinafter in this specification shall not be considered as relieving any Division from the above - indicated responsibility.
- .10       Equivalent or equal products: Where either of these terms are used to reference acceptable material, proof of equality in the form of manufacturer's representative supplied itemized table or letter, to illustrate or certify that the product meets or exceeds each and every specification item is required for review prior to approval. Manufacturer catalog pages are not acceptable substitute for the above-indicated table or letter and will be returned as insufficient for review.
- .11       Contract documents are issued to facilitate construction by expressing the design intent. The drawings and specifications do not necessarily contain all the details required to construct the project. Contractor supplied detail in the form of detailed construction documents, referred to in the contract documents as the contractor supplied shop

drawings, submittals and field coordination drawings, is required for construction of the work, all of which set out the specific and final details required for placing and constructing the finished work. By contrast, the drawings and specifications are provided to reflect the finished design of the work. The drawings and specifications are not intended to be used as a set of detailed instructions on how to construct the work. Construction means, methods, techniques, sequences, procedures and site safety precautions are the responsibility of the contractor.

- .12 Examine the drawings and specifications to satisfy yourself regarding the design intent and the extent of the proposed work by personal examination of the site and surroundings. Make your own estimate therefrom of the facility and difficulties attending the performance and completion of the work.

## 1.2 ABBREVIATIONS

- .1 Abbreviations for electrical terms shall be to CSA Z85-1983.

- .2 Names used throughout these specifications are:

EEMAC	Electrical & Electronic Manufacturers Association of Canada
CSA	Canadian Standards Association
UL	Underwriters' Laboratory
FM	Factory Mutual
NEMA	National Electrical Manufacturers Association (U.S.)
JIC	Joint Industry Conference
IPCEA	Insulated Power Cable Engineers Association
ISA	Instrument Society of America
CEC	Canadian Electrical Code
IEEE	Institute of Electrical and Electronic Engineers
IES	Illuminating Engineering Society
NBC	National Building Code
ANSI	American National Standards Institute
OESC	Ontario Electrical Safety Code
OBC	Ontario Building Code

## 1.3 CODES AND STANDARDS

- .1 Unless otherwise indicated, all references to standards and codes throughout this specification is to the latest applicable edition at the time of bid closing.
- .2 Do complete installation in accordance with CSA C22.1. In case of a conflict between the code requirements and the contract documents, request clarification prior to proceeding with the work.
- .3 Do overhead and underground systems in accordance with CSA C22.3 No.1 except where specified otherwise.
- .4 Abbreviations for electrical terms: to CSA Z85 Abbreviations for Scientific and Engineering Terms.
- .5 Coordinate with other disciplines and provide plenum rated equipment and devices and plenum rated raceway, wiring and installation methods in all plenum spaces.
- .6 Material and installations shall comply with the requirements of the following codes and standards, codes and standards mentioned in other sections of this

specification, as well as other applicable codes and standards to the satisfaction of the Authorities Having Jurisdiction (AHJ):

- .1 Ontario Building Code (OBC)
  - .2 National Fire Code of Canada (NFCC);
  - .3 Ontario Electrical Safety Code (OESC);
  - .4 Canadian Standards Association (CSA); and
  - .5 Underwriters Laboratories of Canada (ULC).
- .7 Provide the site office with a current copy of the following documents, codes and standards. These documents shall remain on site throughout the duration of construction for electricians and others reference and use. The maintenance of these codes on site may be checked at each site visit. Absence of one or more such documents will be indicated on the field review report as deficiency and non-compliance with contract requirements. A hold back may be applied to the progress claims until the deficiency is rectified to the satisfaction of the Consultant.
- .1 Project's electrical specifications;
  - .2 Project's up to date electrical RFIs and responses, SIs and CCNs;
  - .3 Canadian Electrical Code;
  - .4 CAN/ULC-S524, Installation of Fire Alarm Systems; and
  - .5 CAN/ULC-S537, Verification of Fire Alarm Systems.

#### **1.4 QUALITY ASSURANCE**

- .1 Conform to the requirements of OESC with amendments by local Authorities Having Jurisdiction (AHJ).
- .2 Conform to the requirements of the OBC with amendments by local AHJ.
- .3 Obtain and pay for the electrical permits, plan review, and inspection from local AHJ.
- .4 Conform to the requirements of the serving electric, telephone and cable television utilities..

#### **1.5 CARE, OPERATION AND START-UP**

- .1 Instruct operating personnel in the operation, care and maintenance of systems, system equipment and components.
- .2 Arrange and pay for services of manufacturer's authorized installer/service engineer to supervise start-up of installation, check, adjust, balance and calibrate components and instruct operating personnel.
- .3 Provide these services for such period, and for as many visits as necessary to put equipment in operation, and ensure that operating personnel are conversant with all aspects of its care and operation.

#### **1.6 VOLTAGE RATINGS**

- .1 Operating voltages: to CAN3-C235 Preferred Voltage Levels for AC Systems 0 to 50kV.
- .2 Motors, electric heating, control and distribution devices and equipment to operate satisfactorily at 60 Hz within normal operating limits established by the above indicated standard. Equipment to operate in extreme operating conditions established in above-indicated standard without damage to equipment.

## **1.7 PERMITS, FEES AND INSPECTION**

- .1 Submit to Electrical Inspection Department and Supply Authority necessary number of drawings and specifications for examination and approval prior to commencement of work.
- .2 Pay associated fees.
- .3 Engineer will provide drawings and specifications required by Electrical Inspection Department and Supply Authority at no cost.
- .4 Notify Consultant of changes required by Electrical Inspection Department prior to making such changes.
- .5 Furnish Certificates of Acceptance from authorities having jurisdiction on completion of work to Consultant.

## **1.8 MATERIALS AND EQUIPMENT**

- .1 Provide materials and equipment in accordance with Section 01 61 00 - Common Product Requirements.
- .2 Equipment and material to be certified by a SCC (Standard Council of Canada) accredited Certification body. Where there is no alternative to supplying equipment, which is not certified as indicated, obtain special approval from Electrical Inspection Department.
- .3 Equipment and material to be in compliance with the current applicable federal and local Territorial laws, regulations and acts.
- .4 Factory assemble control panels and component assemblies.
- .5 Provide material and equipment that is acceptable to AHJ as suitable for the use indicated. For example, provide wet label equipment in wet locations.
- .6 Include special features, finishes, accessories and other requirements as described in the contract documents regardless of the items listed catalog number.
- .7 Provide incidentals not specifically mentioned herein or noted on drawings, but needed to complete the system, in a safe and satisfactory working condition.
- .8 Install electrical equipment complete and per manufacturer's instructions. Obtain installation instructions from manufacturer and thoroughly examine the instructions prior to rough in. When instructions conflict with contract documents, request clarification from Consultant prior to proceeding with the installation.
- .9 All material including but not limited to lubricants, caulking, glue, cleaners, paints and finishings shall comply with the requirements of LEED Indoor Environmental Quality prerequisites and credits.

## **1.9 ELECTRIC MOTORS, EQUIPMENT AND CONTROLS**

- .1 Supplier and installer responsibility is indicated in Motor, Control and Equipment Schedule on electrical drawings and related mechanical responsibility is indicated on mechanical drawings and in mechanical specifications.
- .2 Control wiring and conduit is specified in Division 26 except for conduit, wiring and connections below 50 V, which are related to control systems specified in Division 23 and shown on mechanical drawings.
- .3 Except where otherwise indicated, provide all feeders, breakers, disconnects, starters, overloads and power relays as indicated on drawings or required by applicable codes, whichever more stringent.

- .4 Except where otherwise indicated, coordinate with controls contractor and provide all breakers and 120V feeders to valves, dampers, control panels, sequencers, etc.

### 1.10 FINISHES

- .1 Shop finish metal enclosure surfaces by application of rust resistant primer inside and outside, and at least two coats of finish enamel.
- .2 Clean and touch up surfaces of devices and equipment scratched or marked during shipment or installation, to match original paint.
- .3 Clean and prime exposed non-galvanized hangers, racks and fastenings to prevent rusting.
- .4 All electrical fittings, supports hanger rods, pullboxes, channel frames, conduit racks, outlet boxes, brackets, clamps, etc. to have galvanized finish or enamel paint finish over corrosion-resistant primer.
- .5 All panelboards, distribution centres, transformers, etc. to be factory finished in gloss air dry enamel applied over corrosion-resistant primer. Matte or flat type finish paint not acceptable. Factory finished units that are scratched or marked during installation or shipping to be touched up with matching spray-on air dry lacquer or, if required to provide a satisfactory job, completely refinished.
- .6 All 347/600 and 120/208 volt equipment to be finished to match Beige BE50-P2642 by Spectrum Powder Manufacturing Inc. and grey ANSI 61 respectively. Transformers are considered 347/600 volt.
- .7 Fire alarm pullboxes and junction boxes to be finished in red.
- .8 Telephone terminal panels and junction boxes to be finished in white.
- .9 Intercommunication and sound terminal panels and junction boxes to be finished in yellow.
- .10 Low voltage switching terminal cabinets and pullboxes to be finished in black.
- .11 Structured wiring boxes and raceways to be finished in blue.

### 1.11 EQUIPMENT IDENTIFICATION

- .1 Identify electrical equipment with nameplates as follows:
- .2 Nameplates: Lamicoid 3 mm thick plastic engraving sheet, black face, white core, mechanically attached with self tapping screws.  
NAMEPLATE SIZES  

Size 1	10 x 50 mm	1 line	3 mm high letters	Type C
Size 2	12 x 70 mm	1 line	6 mm high letters	Type B
Size 4	20 x 90 mm	1 line	9.5 mm high letters	Type A
- .3 Labels: Embossed plastic labels with 6 mm high letters unless specified otherwise.
- .4 Wording on nameplates to be approved by Consultant prior to manufacture.
- .5 Allow for average of twenty-five (25) letters per nameplate and label.
- .6 Identification to be English.
- .7 Nameplates for terminal cabinets and junction boxes to indicate system and/or voltage characteristics.
- .8 Panelboard label to include:

- .1 The word "PANELBOARD" followed by the panelboard identification (ID) as shown on drawings;
- .2 Voltage, phase and number of wires; and
- .3 The words "FED FROM" followed by the source ID, and circuit number where applicable.
- .9 Relay panels: Similar to Panelboards.
- .10 Disconnects', starters' and contactors' label to include:
  - .1 Load ID as shown on drawings;
  - .2 Voltage, Voltage, phase and number of wires;
  - .3 The words "FED FROM PANEL" followed by the source ID; and
  - .4 The abbreviations "CCT #" followed by the circuit number or numbers as applicable.
- .11 Motors and other mechanical loads: Similar to disconnects.
- .12 Terminal cabinets and pull boxes: indicate system, voltage and circuit number(s).
- .13 Transformer label to include:
  - .1 The word " TRANSFORMER" followed by the transformer ID as shown on drawings;
  - .2 KVA Rating, Primary voltage Phase and number of wires, and Secondary voltage Phase and number of wires;
  - .3 The words "FED FROM PANELBOARD" followed by the source ID as shown on drawings; and
  - .4 The words "SUPPLIES" followed by the load ID as shown on drawings.
- .14 On/Off switches: indicate areas being served.
- .15 Identifications shall match what is shown on drawings as to the letters, numbers, sequence, indentation and other formatting attributes.

## 1.12

### WIRING IDENTIFICATION

- .1 Identify each conductor at each end where they are spliced or terminated in a junction box, panelboard, fitting or device.
- .2 Identify conductors that pass through a pullbox in that box.
- .3 Identify wiring with permanent indelible identifying markings as indicated hereinafter.
- .4 Identification tag to indicate the panel designator and circuit number or wire number on each conductor. Information shall be printed in permanent legible form.
- .5 Tag neutral conductor with the circuit number that it serves.
- .6 Tag switched conductors with "SW" after circuit identification.
- .7 Maintain phase sequence and colour coding throughout for all systems.
- .8 Colour code the wiring per CSA C22.1 as follows:
  - .1 120/208 volt system phase wires - Red, Black and Blue.
  - .2 Colour coding of phase conductors:
  - .3 Number 10 AWG conductors and smaller shall be Red, Black, Blue, Orange, Brown, Yellow, White as required.
  - .4 Number 8 to 3 AWG conductors shall be Red, Black, Blue, White for 120/208 volt systems. For 347/600 volt systems use either Orange,

Brown and Yellow colour coded conductors or use colour banding of Orange, Brown and Yellow on the Red, Black and Blue conductors for such identification.

- .5 Larger than number 3 AWG conductors can be black with appropriate banding.
- .9 Use colour coded wires in communication cables, matched throughout system.

### **1.13 WIRING TERMINATIONS**

- .1 Lugs, terminals, screws used for termination of wiring to be suitable for either copper or aluminum conductors.

### **1.14 MANUFACTURERS AND SCC LABELS**

- .1 Visible and legible, after equipment is installed.

### **1.15 PROTECTION**

- .1 Protect exposed live equipment during construction for personal safety.
- .2 Shield and mark live parts "LIVE 120 VOLTS", or with appropriate voltage setting.

### **1.16 LOCATION OF OUTLETS**

- .1 Locate outlets in accordance with Article 1.20 this Section.
- .2 Do not install outlets back-to-back in wall; allow minimum 150 mm horizontal clearance between boxes.
- .3 Change location of outlets at no extra cost or credit, providing distance does not exceed 3000 mm, and information is given before installation.
- .4 Locate light switches on latch side of doors. Locate disconnect devices in mechanical room (eg. boiler emergency) and elevator machine room on latch side of the door.

### **1.17 LOAD BALANCE**

- .1 Measure phase current to panelboards with normal loads (lighting, HVAC, etc.) operating at time of acceptance. Adjust branch circuit connections as required to obtain balance of current between phases to within 15% of average and record changes.
- .2 Measure phase voltages at loads and adjust transformer taps to within 2% of rated voltage of equipment.
- .3 Submit, at completion of work, report listing phase and neutral currents on panelboards, dry-core transformers and motor control centres, operating under normal load. State hour and date on which each load was measured, and voltage at time of test.

### **1.18 FIELD QUALITY CONTROL**

- .1 All electrical work to be carried out by qualified, licensed electricians or apprentices as per the conditions of the Territorial Act respecting manpower vocational training and qualification. Employees registered in a Territorial apprentices program shall be permitted, under the direct supervision of a qualified licensed electrician, to perform specific tasks - the activities permitted shall be determined based on the level of training attained and the demonstration of ability to perform specific duties.

- .2 The work of this division to be carried out by a contractor who holds a valid Master Electrical contractor license as issued by the Territory that the work is being contracted.
- .3 Conduct and pay for all testing unless otherwise indicated.
- .4 Furnish manufacturer's certificate or letter confirming that entire installation as it pertains to each system has been installed to manufacturer's instructions.
- .5 Insulation resistance testing:
  - .1 Megger circuits, feeders and equipment up to 300 V with a 500 V instrument.
  - .2 Megger 300-600 V circuits, feeders and equipment with a 1000 V instrument.
  - .3 Check resistance to ground before energizing.
  - .4 Electronic instruments shall not be subjected to a megger test. Damaged electronic instrument(s) caused by megger test(s) shall be replaced at contractor's expense.
  - .5 Consider ambient temperature and weather conditions, and apply proper correction factors to the measured insulation resistance values.
  - .6 When directed to do so, carry out tests in presence of Consultant.
  - .7 Provide instruments, meters, equipment and personnel required to conduct tests during and at conclusion of project.
  - .8 Complete all deficient items noted on reports provided by the local authority having jurisdiction.
  - .9 Submit test results for Consultant's review.

#### **1.19 CO-ORDINATION OF PROTECTIVE DEVICES**

- .1 Ensure circuit protective devices such as overcurrent trips, relays and fuses are installed to required values and settings as recommended by manufacturer for a fully discriminative protection.

#### **1.20 SHOP DRAWINGS AND PRODUCT DATA**

- .1 In accordance with Section 01 33 00 - Submittal Procedures.
- .2 Shop Drawings:
  - .1 Shop drawings means technical data specially prepared for work of this contract including drawings, diagrams, performance curves, data sheets, schedules, templates, patterns, reports, calculations, instructions, measurements and similar information not in standard printed form.
  - .2 Submit shop drawings presented in a clear and thorough manner to appropriately illustrate the work.
  - .3 Identify shop drawings by appropriate references to sheet, detail, schedule or room number. Maximum allowable drawing size 11" x 17". Provide a clear area of 100mm x 75mm (4" x 3") on each shop drawing for Engineer's review stamp.
- .3 Product Data:
  - .1 Product data means standard printed information describing materials, products, equipment and systems, not specially prepared for
  - .2 Product data consisting of manufacturers' standard schematic drawings, catalogue sheets, diagrams, schedules, performance charts, illustrations

and descriptive data will be accepted in lieu of shop drawings provided that:

- .1 Information not applicable to the work of this contract is deleted, or the applicable information is clearly marked; and
- .2 Standard information is supplemented with information specifically applicable to work of this contract.

.4 General:

- .1 Review, stamp with approval and sign shop drawings before submission to Consultant. Stamping and signing the transmittal only, is not acceptable. By approving and submitting shop drawings, contractor represents that field measurements, field construction criteria, material, catalogue numbers and similar data have been verified and that shop drawings have been checked and coordinated with requirements of the work and contract documents regardless of what the stamp says.
- .2 Consultant's review of shop drawings shall be completed by the electrical sub-contracting firm and not the general contractor. Review shall be completed and review stamp shall be signed by a qualified person in electrical discipline by education and experience who is an employee of the electrical subcontracting firm. Shop drawings signed by a non-qualified person or an administrative assistant will be rejected.
- .3 At the time of submission, inform Consultant in writing of any deviations in shop drawings from requirements of Contract Documents.
- .4 Consultant will review shop drawings for the sole purpose of ascertaining conformance with general design concept of the project and with information given in Contract Documents. Consultant's review of a separate item shall not indicate acceptance of an assembly in which the item functions. This review by Consultant shall not mean that Consultant approved the detail design inherent in the shop drawings, responsibility for which shall remain with the Contractor submitting same, and such review shall not relieve the Contractor of his responsibility for errors or omissions in the shop drawings or his responsibility for meeting all requirements of the Contract documents as well as applicable federal and provincial/territorial laws, regulations and acts.
- .5 Make corrections which Consultant may require, consistent with Contract Documents, and resubmit modified shop drawings until reviewed.
- .6 Direct specific attention in writing on re-submitted shop drawings to revisions requested by Consultant on previous submissions.
- .7 Be responsible for dimensions to be confirmed and correlated at job site for information that pertains solely to fabrication processes or to techniques of construction and installation and for coordination of the work of all Sections.
- .8 Shop drawings submitted in Imperial will be returned to the contractor not reviewed until they are submitted in Metric Units (SI).
- .9 Shop drawings which require the approval of a legally constituted authority having jurisdiction shall be submitted by Contractor to such authority for approval. Such shop drawings shall receive final approval of authority having jurisdiction before receiving Consultant's final review.

- .10 No work requiring a shop drawing submission shall commence until the submission has received Consultant's final review. All such work shall be in accordance with reviewed shop drawings.
- .11 Provide submittals for review for all electrical material and equipment.
- .5 Substitution requests shall be complete with proper support documents to clearly identify the equality of the specifications of the suggested product on an item by item basis compared to the specifications listed for the specified product. Requests not meeting this requirement, will be returned as insufficient information for review.
- .6 No substitution of items specifically called for on the drawings, such as feeders, etc., with other products even the ones listed in specifications, is allowed without timely and proper request and approval.

### **1.21 RECORD DRAWINGS**

- .1 Provide 1 set of marked up electrical site record drawings. Provide sets of white prints of the construction drawings and use for record drawings. Mark thereon all changes as work progresses and as changes occur. This shall include changes to all electrical systems as constructed, including any revisions from addenda or change orders. Ensure that items marked correspond to the drawing title.
- .2 Use different colour waterproof ink for each service on a per drawing basis.
- .3 Make mark-ups available for reference purposes and inspection at all times.
- .4 Submit the final record marked up hard copies to the Consultant at the time of final completion.
- .5 Pay for the costs of the above-indicated items.
- .6 A hold back will be applied towards receipt of final record marked up hard copy until all deficiencies are rectified to Consultant's satisfaction.

### **1.22 OPERATION AND MAINTENANCE DATA**

- .1 Include in Operation and Maintenance Data:
  - .1 Component function and maintenance requirements, to permit effective start-up, operation, maintenance, repair, modification, extension and expansion of any portion or feature of installation.
  - .2 Wiring and schematic diagrams indicating all connections, terminals and wire numbers.
  - .3 Names and address of all suppliers for items must be included in the Maintenance Manuals.
  - .4 All manufacturer's operating and maintenance information prepared for any installed equipment.
  - .5 Shop drawings of all installed equipment.
  - .6 Results of all tests performed.
  - .7 Spare parts list.
  - .8 All studies, test reports, testing certificates and Inspection Department acceptances.
  - .9 One set of full size prints of record drawings.
  - .10 One copy of all panel directories.
- .2 Provide per section 01 78 00 - Closeout Submittals.

- .3 Neatly type lists and notes. Use clear drawings diagrams or manufacturers' literature.
- .4 Submit operation and maintenance manuals before or with request for final field review.

### **1.23 CLEANING**

- .1 Thoroughly clean the interior and the exterior of all switchboards, panelboards, transformers, cabinets, wireways and gutters, enclosures, boxes and the like in accordance with manufacturer's instructions.
- .2 Vacuum construction dust, dirt and debris out of all electrical equipment and device enclosures including but not limited to the above-mentioned list.
- .3 Where enclosure finish is damaged, touch up finish with matching paint in accordance with manufacturer's specifications and installation instructions.

## **Part 2 Products**

### **2.1 MATERIALS AND EQUIPMENT**

- .1 Equipment and material shall be CSA or cUL certified, or carry an alternative certification recognized by the local Authority Having Jurisdiction for the specific type of equipment.
- .2 Where multiple components are assembled in an enclosure to form an electrical piece of equipment, the overall piece of equipment shall carry certification recognized by the local Authority Having Jurisdiction.
- .3 Where there is no alternative to supplying equipment which is not CSA or cUL certified, obtain special approval from the Authority Having Jurisdiction.
- .4 Factory-assemble and test control panels and component assemblies prior to delivery of panels and assemblies to the site.
- .5 Where two or more units of the same class or type of equipment are required, the units shall be the product of a single manufacturer, although components of equipment need not be products of the same manufacturer.
- .6 Use material and equipment available from regular production of manufacturer.

### **2.2 SPRINKLER PROOF REQUIREMENTS**

- .1 All equipment and wiring systems shall be sprinklerproof where sprinkler fire protection systems are installed.

### **2.3 HANGERS AND SUPPORTS**

- .1 Provide hangers, angles, channels, and other supports necessitated by field conditions to install all items of electrical equipment. Design of supports and methods of fastening to building structures shall be subject to the Engineer's approval.
- .2 All local motor control devices shall be grouped and mounted on a free-standing frame of stainless steel construction easily accessible and as close to the motor as possible.

- .3 Provide weight-distribution facilities, where required, so as not to exceed the load-bearing capacities of floors or walls that bear the weight of, or support, electrical items.
- .4 In standard interior locations, paint all exposed parts of hangers and supports with a rust inhibiting primer. In pool control rooms, chlorine storage or handling areas, and other highly corrosive areas, provide supports, channels, brackets, rods, clamps, anchors and fasteners of Type 316 stainless steel or nonmetallic corrosion-resistant materials suitable for the imposed load and environment. Zinc-plated, electro-galvanized, painted mild steel, and similar ferrous hardware are not acceptable in these areas.
- .5 Equipment shall not be held in place by its own weight. Provide base anchor fasteners in each case.

## **2.4 ENCLOSURES**

- .1 Enclosures used throughout the project shall be CSA 4X, non-metallic, unless a more stringent requirement is indicated on the drawings. In case of a conflict between this section and other documents, more stringent requirement shall be used.

## **Part 3 Execution**

### **3.1 WORKMANSHIP**

- .1 Workmanship shall be in accordance with well established practice and standards accepted and recognized by the Consultant and the Trade.
- .2 The Consultant shall have the right to reject any item of work that does not conform to the Contract Documents and accepted standards of performance, quietness of operation, finish and appearance.

### **3.2 MOUNTING HEIGHTS**

- .1 Mounting height of equipment is from finished floor to centerline of equipment unless specified or indicated otherwise.
- .2 If mounting height of equipment is not specified or indicated, verify before proceeding with installation.
- .3 Install electrical equipment at following heights unless indicated otherwise.
  - .1 Local switches: 1200 mm.
  - .2 Wall receptacles:
    - .1 In mechanical rooms: 1200 mm.
  - .3 Other electrical devices with operable components: 1200 mm, unless otherwise indicated.
- .4 Matching types of devices in the same space shall be mounted at matching elevation.

### **3.3 CONDUIT AND CABLE INSTALLATION**

- .1 If plastic sleeves are used in fire rated walls or floors, remove before conduit installation.

- .2 Keep power feed cables separated from any control, instrumentation, or communications cables by sufficient distance to prevent electrical interference by the power feeds onto any of the control, instrumentation, or communications cables. Where these types of cables must cross, the crossings shall be perpendicular to each other.
- .3 Exposed raceways shall be rigid PVC conduit, RTRC/fiberglass conduit, or other nonmetallic raceway system specifically suitable for corrosive chemical service and acceptable to the Authority Having Jurisdiction. Provide matching nonmetallic boxes and fittings wherever practicable. Where a metallic component is unavoidable for equipment connection, provide Type 316 stainless steel or factory PVC-coated corrosion-resistant components specifically intended for corrosive service. Use stainless steel screws, anchors and fastening hardware at all raceway supports and terminations. Arrange installation to minimize top entry into enclosures and seal raceways to limit migration of corrosive vapours and condensate.
- .4 Where sleeves or openings are installed in walls, floors, roof or partitions to accommodate raceways, cables or bus duct, provide all necessary seals, fittings, barriers and fire-resistant materials to restore the installation to its original fire rating to the satisfaction of the Engineer and the Owner's insurance underwriters.

### **3.4 APPROVED DESIGN AND INSTALLATION**

- .1 Install equipment in strict accordance with manufacturer's recommendations and governing rules, regulations and codes.
- .2 Where requirement conflict occurs, allow for supply install of all materials in accordance with the most stringent and most expensive requirements.
- .3 All materials supplied and installed under this Division shall be new, unless explicitly stated otherwise on the drawings, and of uniform construction.
- .4 All installations are to ensure maximum headroom, minimum interference with free use of surrounding areas, and best access to equipment.
- .5 To deviate major service runs from the location shown on the drawings, submit to the Engineer suitable drawings showing such deviations together with reasons for deviations and obtain approval from the Engineer before proceeding with the installation.

### **3.5 FIELD QUALITY CONTROL**

- .1 All electrical work to be carried out by qualified, licensed electricians or apprentices as per the conditions of the Provincial Act respecting manpower vocational training and qualification. Employees registered in a provincial apprentices program shall be permitted, under the direct supervision of a qualified licensed electrician, to perform specific tasks - the activities permitted shall be determined based on the level of training attained and the demonstration of ability to perform specific duties.
- .2 The work of this division to be carried out by a contractor who holds a valid Master Electrical contractor license as issued by the Province that the work is being constructed.
- .3 Prior to the Engineer's acceptance, all electrical equipment, materials and systems installed shall be subject to an inspection and applicable performance tests supervised by

the Engineer to ensure that the operation of the system and components satisfy the requirements of the Specifications.

- .4 Ensure that the system and its components are ready prior to the inspection and test for acceptance.
- .5 All testing shall be conducted by fully qualified personnel only. Tests requiring initial power energization of a system shall not be made without notification of the Engineer. Tests, checks and the like carried out by or on behalf of the Contractor shall be documented and certified at no additional cost to the Owner. Submit three copies of the test certificates to the Engineer. Carefully check wiring for each system and/or part of a system to ensure that the system will function properly as indicated by wiring and schematic diagrams, description of operation, etc.
- .6 Manually operate alarms and control devices to check whether their operation during normal and abnormal operating conditions causes the proper effect.
- .7 In addition to tests on purely electrical systems, supply the necessary labour and equipment for operational tests required by other Divisions where electrical services are involved and make final adjustments to the electrical controls at no additional cost to the Owner.
- .8 Perform tests on auxiliary or specialized systems with the assistance of the manufacturer's representative. Upon successful conclusion of the tests, obtain a certificate from the manufacturer stating that the system has been installed to their satisfaction and that it is in good working order.
- .9 Ensure circuit protective devices such as overcurrent trips, relays and fuses are installed to values and settings as indicated.
- .10 Insulation resistance testing.
  - .1 Megger circuits, feeders and equipment up to 350 V with a 500 V instrument.
  - .2 Megger 350-600 V circuits, feeders and equipment with a 1000 V instrument.
  - .3 Check resistance to ground before energizing.
  - .4 Record all test results in a log book and submit to the Engineer for reference. Replace or repair all circuits, which do not meet minimum requirements specified in the Electrical Code, Table 24. Insulation resistance of the following circuits shall be measured:
    - .1 Power, lighting and motor feeders: phase-to- phase, phase-to-neutral and phase-to- ground.
    - .2 Control circuits: measure to ground only.
- .11 Provide instruments, meters, equipment and personnel required to conduct tests during and at conclusion of project.
- .12 Submit test results for Engineer's review.

### **3.6 DELIVERY AND STORAGE**

- .1 Ship and store equipment in accordance with manufacturer's recommendations.
- .2 Ship channel bases and anchor stencils in advance of equipment.

- .3 Keep equipment doors locked. Protect equipment from damage, dust and weather during shipping and storage.
- .4 Block moving parts when necessary to prevent damage during movement and shipment of equipment. Instructions to remove blocking before putting equipment in service to be clearly and conspicuously displayed.
- .5 Store all electrical equipment indoors. Temperature sensitive equipment to be stored in heated spaces.

### **3.7 CLEANING**

- .1 Do final cleaning in accordance with Division 01 and as specified in other Sections.
- .2 Clean and touch up surfaces of shop-painted equipment scratched or marred during shipment or installation, to match original paint.

### **3.8 CARE, OPERATION AND START-UP**

- .1 Instruct operating personnel in the operation, care and maintenance of systems, system equipment and components. Keep training sign-in sheet complete with date, name of training instructor, names and signatures of attendees. Include a copy of sign-in sheet in the OM manual.
- .2 Arrange and pay for services of manufacturer's factory service engineer to supervise start-up of installation, check, adjust, balance and calibrate components and instruct operating personnel.
- .3 Provide these services for such period, and for as many visits as necessary to put equipment in operation, and ensure that operating personnel are conversant with all aspects of its care and operation.

**END OF SECTION**

**Part 1            General**

**1.1                RELATED SECTIONS**

- .1            Section 26 05 20 - Wire and Box Connectors - 0 - 1000 V.

**1.2                REFERENCES**

- .1            CSA C22.2 No .0.3, Test Methods for Electrical Wires and Cables.
- .2            CAN/CSA-C22.2 No. 131, Type TECK 90 Cable.

**Part 2            Products**

**2.1                BUILDING WIRES**

- .1            Conductors: stranded for 10 AWG and larger. Minimum size: 12 AWG.
- .2            Copper conductors: size as indicated, with 600 V insulation of chemically cross-linked thermosetting polyethylene material rated RW90.
- .3            Aluminum conductors are not permitted.

**2.2                TECK CABLE**

- .1            Cable: to CAN/CSA-C22.2 No. 131.
- .2            Conductors:
  - .1            Grounding conductor: copper.
  - .2            Circuit conductors: copper, size as indicated.
- .3            Insulation:
  - .1            Type: ethylene propylene rubber.
  - .2            Chemically cross-linked thermosetting polyethylene rated type RW90, 1000 V.
- .4            Armour: interlocking aluminum.
- .5            Overall covering: sunlight-, moisture-, and chemical-resistant CPE, CSPE, or equivalent corrosion-resistant low-smoke, low-acid-gas jacket specifically rated by the cable manufacturer for chlorinated gas service. PVC outer covering is not acceptable in the chlorinated gas exposure zone.
- .6            Fastenings:
  - .1            One hole Type 316 stainless steel straps to secure surface cables 50 mm and smaller. Two hole Type 316 stainless steel straps for cables larger than 50 mm.
  - .2            Channel type supports for two or more cables, fabricated from Type 316 stainless steel or FRP with stainless steel hardware, suitable for corrosive chemical service.
  - .3            Threaded rods: 6 mm dia. minimum, Type 316 stainless steel, to support suspended channels.
- .7            Connectors:

- .1 Watertight, corrosion-resistant, Type 316 stainless steel or alternative fittings approved by cable manufacturer and specifically suitable for chlorinated gas exposure.
  - .1 Provide sealing components and jackets/glands compatible with the cable outer jacket material.

### **2.3 CONTROL CABLES**

- .1 Conductors: multiconductor, copper, unshielded pair or overall shielded as indicated, minimum size to be #16 AWG. Provide tinned copper conductors and drain wire where cable is installed in the chlorinated gas exposure zone.
- .2 Insulation: XLPE, CPE, or other manufacturer-recommended insulation system suitable for the specified chlorinated gas environment and minimum 105°C rating.
- .3 Aluminum foil/polyester shield with tinned copper drain wire.
- .4 Jacket to be sunlight-, moisture-, and chemical-resistant CPE, CSPE, or equivalent thermoset/thermoplastic compound specifically rated by the manufacturer for corrosive chlorinated gas exposure; sequentially marked; nylon ripcord for jacket removal.
- .5 Conductors are to be black/white number coded, rated for 300V or 600V at 105°C.
- .6 Standard of Acceptance: manufacturer's chemical-resistant instrumentation/control cable specifically recommended for corrosive chlorinated gas environments, or approved equal.

## **Part 3 Execution**

### **3.1 INSTALLATION OF TECK CABLE 0 -1000 V**

- .1 Install cables.
  - .1 Group cables wherever possible on channels.
- .2 Install cable in trenches in accordance with Section 26 05 44.
- .3 Terminate cables in accordance with Section 26 05 20- Wire and Box Connectors - 0 - 1000 V.
- .4 Within chlorinated gas exposure zones, install only cable, fittings, supports, and accessories specifically rated for corrosive chemical service. Avoid exposed aluminum, galvanized steel, and zinc-plated components within these areas.

### **3.2 INSTALLATION OF ARMoured CABLES**

- .1 Group cables wherever possible.
- .2 Terminate cables in accordance with Section 26 05 20 - Wire and Box Connectors - 0 - 1000 V.

### **3.3 INSTALLATION OF CONTROL CABLES**

- .1 Install control cables in conduit.

- .2 Ground control cable shield.
- .3 Where control cables pass through chlorinated gas exposure zones, install in continuous corrosion-resistant conduit or provide manufacturer-certified cable construction specifically suitable for the environment. Seal entries to limit ingress of corrosive gas into equipment enclosures.
- .4 All costs associated with the supply and installation of low voltage control wiring for 50V and under and related materials to be carried by Divisions 23 and 25 unless otherwise noted in the project documents.
- .5 Provide line voltage control wiring, raceway and terminations. Coordinate with Divisions 23 and 25 at the time of tender and bid accordingly. Failed to do so, provide all necessary whatsoever at no extra cost.

### 3.4 VOLTAGE REGULATION

- .1 The drawings indicate the general routing of conduit runs and not exact routing, either horizontally or vertically.
- .2 Branch circuit conductor sizes shall be #12 AWG or larger based on the routing of conduit and run lengths as shown on the drawings, and shall comply with the Canadian Electrical Code, Part I, which allows a maximum 3% voltage drop for branch circuits.
- .3 All voltage drop calculations to be based on the Ontario Electrical Safety Code (OESC), Part I, and utilizing a current of 80% of the circuit protective device specified.
- .4 When exact run lengths are determined for all branch circuits, and prior to installation of the conductors, ensure that the maximum voltage drop (based on 80% of circuit protective device) does not exceed 3%. Increase wire size from #12 AWG, if necessary, to ensure that the 3% voltage drop is not exceeded.
- .5 Reference conductor length schedule:

Conductor	Maximum One-way Length of Run	
	120 Volts	347 Volts
#12	20 m	65 m
#10	35 m	105 m
#8	55 m	175 m
#6	95 m	280 m

The above table is based on 80% capacity of a 15 amp circuit. All other loads will require calculations to be conducted by the installing contractor to determine appropriate wire size as per the OESC.

**END OF SECTION**

**Part 1            General**

**1.1                REFERENCES**

- .1        CSA C22.1, Canadian Electrical Code, Part 1.
- .2        CSA C22.1, Canadian Electrical Code, Part 1. Section 22, Locations in which corrosive liquids, vapours, or excessive moisture are likely to be present, for pool control rooms, chlorine storage rooms, chemical feed areas, and aquatic equipment spaces where corrosive vapours may be present.

**Part 2            Products**

**2.1                OUTLET AND CONDUIT BOXES GENERAL**

- .1        Size boxes in accordance with CSA C22.1.
- .2        102 mm square or larger outlet boxes as required for special devices.
- .3        Surface boxes: CSA 4X, RPVC
- .4        Gang boxes where wiring devices are grouped.
- .5        Blank cover plates for boxes without wiring devices.
- .6        Combination boxes with barriers where outlets for more than one system are grouped.

**Part 3            Execution**

**3.1                INSTALLATION**

- .1        Support boxes independently of connecting conduits.
- .2        Fill boxes with paper, sponges or foam or similar approved material to prevent entry of debris during construction. Remove upon completion of work.
- .3        Install electrical rough-ins in conformance with CSA C22.1 Section 22.

**END OF SECTION**

---

**Part 1            General**

**1.1                REFERENCES**

- .1 Canadian Standards Association (CSA)
  - .1 CAN/CSA C22.2 No. 18, Outlet Boxes, Conduit Boxes, and Fittings and Associated Hardware.
  - .2 CSA C22.2 No. 45, Rigid Metal Conduit, galvanized steel threaded and epoxy coated conduit with zinc coating and corrosion resistant epoxy finish inside and outside.
  - .3 CSA C22.2 No. 56, Flexible Metal Conduit and Liquid-Tight Flexible Metal Conduit.
  - .4 CSA C22.2 No. 211.2, Rigid PVC (Unplasticized) Conduit.
  - .5 CSA C22.1, Canadian Electrical Code, Part I, latest adopted edition by authority having jurisdiction, including without limitation Section 12 - Wiring Methods, Section 22 - Locations in which corrosive liquids, vapours, or excessive moisture are likely to be present, and Section 68 - Pools, Tubs, and Spas.

**1.2                LOCATION OF CONDUIT**

- .1 Drawings do not indicate all conduit runs. Where conduit runs are shown, the runs are in diagrammatic form only. Determine best routing for conduit on site, ensuring requirements of this specification are met.

**Part 2            Products**

**2.1                CONDUITS**

- .1 Rigid PVC conduit: SCH40 RPVC to CSA C22.2 No. 211.2.
- .2 Flexible conduit: liquid-tight flexible nonmetallic conduit.
- .3 Minimum conduit size: ¾" (21mm).

**2.2                CONDUIT FASTENINGS**

- .1 Fastenings and supports in corrosive areas shall be nonmetallic or stainless steel Type 316.
  - .1 Galvanized straps, clamps, channels, rods and miscellaneous support steel are not permitted in chlorine, bromine, or acid vapour environments unless completely isolated from exposure and specifically accepted by Consultant.
- .2 Where attachment to structural steel is required in corrosive areas, provide stainless steel Type 316 beam clamps, clips and hardware, or approved nonmetallic support system.
- .3 Channel supports in corrosive areas shall be fiberglass reinforced plastic, nonmetallic strut system, or stainless steel Type 316 complete with compatible accessories and hardware.
- .4 Threaded rods and suspension hardware in corrosive areas shall be stainless steel Type 316.

## **2.3 CONDUIT FITTINGS**

- .1 Fittings: manufactured for use with conduit specified and suitable for corrosive environments. In chlorine, bromine, or acid vapour areas, provide PVC-coated, nonmetallic, or Type 316 stainless steel fittings as applicable to raceway selected. Provide gasketed, liquid-tight fittings in damp, wet, washdown, or condensate-prone locations.
- .2 Factory "ells" where 90E bends are required for 27 mm and larger conduits.
- .3 Use threaded, gasketed, watertight connectors and couplings in corrosive, damp, wet, and washdown areas. Set-screw fittings are not permitted in corrosive areas.
- .4 Conduit Moisture Sealant: Sealant to be moisture barrier type, non-toxic, non-shrink, non-hardening, putty type hand applied material providing effective barrier under submerged conditions.
- .5 Junction boxes, pull boxes, device boxes and enclosures installed in corrosive areas shall be nonmetallic fiberglass-reinforced polyester, PVC, or Type 316 stainless steel, with gasketed covers and stainless steel hardware. Where sheet-metal enclosures are used, provide corrosion-resistant enclosures suitable for corrosive agents.
- .6 Terminals, bonding hardware, lugs, screws, and other exposed metal components in corrosive areas shall be copper, copper alloy, or Type 316 stainless steel suitable for wet and corrosive environments.

## **2.4 EXPANSION FITTINGS FOR RIGID CONDUIT**

- .1 Weatherproof expansion fittings with internal bonding assembly suitable for 100 mm linear expansion.
- .2 Watertight expansion fittings with integral bonding jumper suitable for linear expansion and 19 mm deflection in all directions.
- .3 Weatherproof expansion fittings for linear expansion at entry to panel.

## **2.5 PULL STRING**

- .1 Minimum 6 mm stranded nylon (polypropylene) pull rope, tensile strength 5 kN. Leave pull rope in conduit after cables have been installed.

## **Part 3 Execution**

### **3.1 INSTALLATION**

- .1 Install conduits to conserve headroom in exposed locations and cause minimum interference in spaces through which they pass.
- .2 Unless noted otherwise on the drawings, use SCH40 RPVC conduit in corrosive areas including:
  - .1 pool equipment rooms,

- .2 pool chemical storage/feed rooms,
- .3 spaces exposed to chlorine, bromine, acid vapours, condensate or washdown.
- .3 Store and climatize SCH40 RPVC conduit, fittings, and solvent cement in the installation space, or in an area with equivalent ambient conditions, for sufficient time prior to installation to allow materials to reach room temperature and humidity conditions in accordance with manufacturer's installation recommendations.
- .4 Install raceways, fittings, boxes, and enclosures in corrosive pool and chemical environments in accordance with CSA C22.1 Section 12, Section 22, and Section 68, and in accordance with manufacturer's installation instructions.
  - .1 Where discrepancy arises between the requirements of the code, manufacturer installation instruction, and this Section, carry the cost for the most stringent and costly requirement.
- .5 Use liquid-tight flexible nonmetallic conduit for final connections to motors, vibration-isolated equipment, and equipment requiring flexibility in damp, wet, washdown, or corrosive locations.
  - .1 Keep flexible connections to the minimum practicable length.
  - .2 Provide liquid tight corrosion resistant couplings in accordance with manufacturer's recommendations.
- .6 Do not route raceways through pool chemical storage or feed rooms unless serving equipment located in that room and no practical alternate route exists. Where routing through such rooms is unavoidable, use only corrosion-resistant raceway systems and minimize joints, boxes, and terminations within the room.
- .7 Bend conduit in accordance with manufacturer's installation instructions.
  - .1 Replace conduit if kinked or flattened more than 1/10th of its original diameter.
- .8 Install pull string in empty conduits impacted by the scope of work.
- .9 Remove and replace blocked, crushed, deformed or otherwise damaged conduit sections.
- .10 Do not use liquids to clean out conduits.
- .11 Where cables or conduits pass through fire rated partitions, fire stop penetrations with the UL listed, engineered fire stopping system.
- .12 Where cables or conduits pass through non-rated walls, pack space between wiring and sleeve full with caulking compound suitable for the application and paint to match the wall finish.
- .13 Dry conduits out before installing wire.
- .14 Seal raceway entries into enclosures in corrosive areas to limit migration of humid, chemical-laden air into panels, starters, control cabinets, pull boxes and other equipment.
  - .1 Provide drains or drain-breather fittings to prevent condensation accumulation.

### **3.2 SURFACE CONDUITS**

- .1 Run parallel or perpendicular to building lines.

- .2 Locate conduits behind infrared or gas fired heaters with 1.5 m clearance.
- .3 Run conduits in flanged portion of structural steel.
- .4 Offset from the walls using non metallic spacer to prevent accumulation of dirt and debris between the wall and the conduit.
- .5 Group multiple conduits supported off the ceiling on suspended stainless steel channels.
- .6 Do not pass conduits through structural members except as permitted by the Structural Engineer.
- .7 Do not locate conduits less than 75 mm parallel to steam or hot water lines with minimum of 25 mm at crossovers.

**END OF SECTION**

**Part 1 General**

**1.1 SECTION INCLUDES**

- .1 Switches, receptacles, wiring devices, cover plates and their installation.

**1.2 RELATED SECTIONS**

- .1 Section 26 05 01 - Common Work Results - Electrical.

**1.3 REFERENCES**

- .1 Canadian Standards Association (CSA International)
  - .1 CSA-C22.2 No.42, General Use Receptacles, Attachment Plugs and Similar Devices.
  - .2 CSA-C22.2 No.42.1, Cover Plates for Flush-Mounted Wiring Devices (Bi-national standard, with UL 514D).
  - .3 CSA-C22.2 No.111, General-Use Snap Switches (Bi-national standard, with UL 20, twelfth edition).
  - .4 CSA C22.1, Canadian Electrical Code, Part I, Section 68 - Pools, Tubs, and Spas.
  - .5 Section 26 05 01 - Common Work Results - Electrical: requirements for products and installation in wet, damp and corrosive locations.

**Part 2 Products**

**2.1 SWITCHES**

- .1 15 A, 120 V, single pole, double pole and three-way switches, premium specification grade, listed and suitable for damp, wet and corrosive natatorium/pool environments where installed.
- .2 Manually-operated general purpose ac switches with following features:
  - .1 Terminal holes approved for No. 10 AWG wire.
  - .2 Silver alloy contacts.
  - .3 Urea or melamine moulding for parts subject to carbon tracking.
  - .4 One piece lexan toggle, lever and cam.
  - .5 Suitable for back and side wiring.
  - .6 White toggle.
  - .7 Provide corrosion-resistant device yokes, mounting straps, screws and exposed metal parts; use stainless steel or non-metallic materials suitable for chlorinated atmospheres.
- .3 Switches of one manufacturer throughout project.

**2.2 RECEPTACLES**

- .1 Switched duplex receptacles, CSA type 5-15R or 5-20R (as indicated), U ground, with break-off links for split-wired switching, to CSA-C22.2 No.42 with following features, and listed and suitable for damp, wet and corrosive natatorium/pool environments where installed:
  - .1 White urea moulded housing.
  - .2 Suitable for No. 10 AWG for back and side wiring.
  - .3 Break-off links for use as split receptacles.

- .4 Eight back wired entrances, four side wiring screws.
  - .5 Triple wipe contacts and riveted grounding contacts.
  - .6 Premium specification grade.
  - .7 Decora style.
  - .8 Provide corrosion-resistant contacts, device yokes, mounting straps, terminal screws and exposed metal parts; use stainless steel or non-metallic materials suitable for chlorinated atmospheres.
- .2 Other receptacles with ampacity and voltage as indicated.
  - .3 Receptacles of one manufacturer throughout project.

**2.3 COVER PLATES**

- .1 Cover plates for wiring devices to: CSA-C22.2 No.42.1.
- .2 Cover plates from one manufacturer throughout project.
- .3 Weatherproof, non-metallic, gasketed, cover plates, to match device configuration.

**Part 3 Execution**

**3.1 INSTALLATION**

- .1 Switches:
  - .1 Install switches in gang type outlet box when more than one switch is required in one location.
  - .2 Mount toggle switches at height in accordance with Section 26 05 01 - Common Work Results - Electrical.
- .2 Receptacles:
  - .1 Install receptacles in gang type outlet box when more than one receptacle is required in one location.
  - .2 Mount receptacles at height in accordance with Section 26 05 01 - Common Work Results - Electrical.
- .3 Cover plates:
  - .1 Install suitable common cover plates where wiring devices are grouped.
  - .2 Do not use cover plates meant for flush outlet boxes on surface-mounted boxes.
- .4 Label all devices in accordance with the requirements of 26 05 00.
  - .1 Clearly indicate on / off positions on all switches.

**END OF SECTION**

## **PART 1 - GENERAL**

### **1.01 RELATED DOCUMENTS**

- A. Drawings and general provisions of the Contract, including General and Supplementary Conditions and Division 01 Specification Sections, apply to this Section.

### **1.02 SUMMARY**

- A. Section Includes:
  - 1. Demolition and removal of selected pool materials and equipment.
  - 2. Salvage of existing items to be reused or recycled.
  - 3. Protection of surrounding areas and equipment.
- B. Related Requirements:
  - 1. Division 1 Section "Temporary Facilities and Controls" for temporary construction and environmental-protection measures for selective demolition operations.
- C. Related work specified in other sections:
  - 1. Section 131100 - Swimming Pools

### **1.03 DEFINITIONS**

- A. Remove: Detach and remove items from the pool/equipment room and legally dispose of them off-site unless indicated to be removed and salvaged or removed and reinstalled.
- B. Remove and Store: Detach and store existing swimming pool items intended for reinstallation and/or reuse.

### **1.04 MATERIALS OWNERSHIP**

- A. Unless otherwise indicated, demolition waste becomes property of the Contractor.

### **1.05 SUBMITTALS**

- A. Proposed Protection Measures: Submit plan and report that indicates the measures proposed for protecting individuals and property for dust control and for noise control. Indicate proposed locations and construction of barriers, if necessary.

### **1.06 CLOSEOUT SUBMITTALS**

- A. Inventory: Submit a list of items that have been removed and salvaged.
- B. Landfill Records: Indicate receipt and acceptance of hazardous wastes by a landfill facility licensed to accept hazardous wastes.

### **1.07 FIELD CONDITIONS**

- A. Owner will occupy portions of building immediately adjacent to selective demolition area. Conduct selective demolition so Owner's operations will not be disrupted.
- B. Conditions existing at time of inspection for bidding purpose will be maintained by Owner as far as practical.
- C. Notify Consultant of discrepancies between existing conditions and Drawings before proceeding with selective demolition.

- D. Hazardous Materials
  - 1. If suspected hazardous materials are encountered, do not disturb; immediately notify Consultant and Owners Representative.
- E. Storage or sale of removed items or materials on-site is not permitted.
- F. Utility Service: Maintain existing utilities indicated to remain in service and protect them against damage during selective demolition operations.
  - 1. Maintain fire-protection facilities in service during selective demolition operations.

## **PART 2 - PRODUCTS**

### **2.01 PERFORMANCE REQUIREMENTS**

- A. Regulatory Requirements: Comply with governing EPA notification regulations before beginning selective demolition. Comply with hauling and disposal regulations of authorities having jurisdiction.
- B. Standards: Comply with OSHA Standards 29 CFR Part 1926 & 1910.
- C. Standards: Comply with ANSI/ASSE A10.6 and NFPA 241.

## **PART 3 - EXECUTION**

### **3.01 EXAMINATION**

- A. Verify that all piping to remain has been plugged before starting selective demolition operations. All piping and pool equipment to remain must fully drained immediately following the draining of the pool until the pool is ready to be refilled and started up for final system commissioning.
- B. Review record documents of existing construction provided by Owners Representative. Owners Representative does not guarantee that existing conditions are same as those indicated in record documents.
- C. Survey existing conditions and correlate with requirements indicated to determine extent of selective demolition required.
- D. When unanticipated mechanical, electrical, or structural elements that conflict with intended function or design are encountered, investigate and measure the nature and extent of conflict. Promptly submit a written report to Consultant.
- E. Survey of Existing Conditions: Record existing conditions by use of preconstruction photographs.
- F. Notify Owner on completion of selective demolition and obtain documentation verifying that existing surfaces have been inspected and accepted.

### **3.02 PREPARATION**

- A. Site Access and Temporary Controls: Conduct selective demolition and debris-removal operations to ensure minimum interference with roads, streets, walks, walkways, and other adjacent occupied and used facilities.
- B. Temporary Facilities: Provide temporary barricades and other protection required to prevent injury to people and damage to adjacent buildings and facilities to remain.
  - 1. Provide protection to ensure safe passage of people around selective demolition area and to and from occupied portions of building.
  - 2. Protect walls, ceilings, floors, and other existing finish work that are to remain or that are exposed during selective demolition operations.

3. Cover and protect furniture, furnishings, and equipment that have not been removed.
4. Comply with requirements for temporary enclosures and dust control.

### **3.03 DISPOSAL OF DEMOLISHED MATERIALS**

- A. General: Except for items or materials indicated to be recycled, reused, salvaged, reinstalled, or otherwise indicated to remain Owner's property, remove demolished materials from Project site and legally dispose of them in an EPA-approved landfill.
  1. Protect all finished surfaces during the demolition process.
  2. Do not allow demolished materials to accumulate on-site.
  3. Remove and transport debris in a manner that will prevent spillage on adjacent surfaces and areas.
- B. Disposal: Transport demolished materials off Owner's property and legally dispose of them.

### **3.04 CLEANING**

- A. Clean adjacent structures and improvements including but not limited to structural spaces of dust, dirt, and debris caused by selective demolition operations. Return adjacent areas to condition existing before selective demolition operations began.

**END OF SECTION**

## **PART 1 - GENERAL**

### **1.01 RELATED DOCUMENTS**

- A. The BIDDING REQUIREMENTS, CONTRACT FORMS, AND CONDITIONS OF THE CONTRACT and applicable parts of DIVISION 1 - GENERAL REQUIREMENTS, as listed in the Table of Contents, be included in, and made a part of this Section.

### **1.02 SUMMARY OF WORK (for general guidance-not inclusive)**

- A. Introduction
1. Provide labor, materials, equipment, and services necessary to renovate the pool and hot tub mechanical and chemical equipment. This work must include installation of products listed in Part 2 of Section 131100.
- B. Work included in this section:
1. It is the intent of this section to place the entire responsibility for the renovation of the pool(s) under one vested Contractor. Under this section the Contractor will provide but is not necessarily limited to the following:
    - a. Provide equipment and services required for erection and delivery onto the premises the equipment or apparatus provided. Remove equipment from premises when no longer required.
    - b. Provide electrical conduit, wiring, junction boxes etc. to low voltage pool equipment within pool filter/chemical rooms per Division 26 - Electrical. (Low voltage is considered less than 110 V.)
    - c. Coordinate for required bonding and grounding of the pool equipment.
    - d. Provide necessary piping and valving as shown on the drawings and specified herein.
    - e. Provide individually sized housekeeping pad for the new competition pool filter as required in the drawings.
    - f. Provide for the storage of pool related equipment, materials, and systems. Items are the responsibility of the Contractor until accepted by the owner.
    - g. Obtain final acceptance by jurisdictional health department(s).
    - h. Start, test, calibrate and adjust mechanical equipment, electrical equipment, recirculation, chemical, and other supplied systems. Instruct the Owner's representative in the systems operation and maintenance as described herein.
- C. Related work specified in other sections:
1. Section 131105 – Selective Demolition
- D. Related work specified in Electrical sections. Reference Division 26 – Electrical. Work that must be completed by others.
1. Ground and bond new pool equipment. Test and verify that the system electrical ground is true and solid. Provide certification to this effort.
  2. Obtain permits, inspections, and approvals of wiring including grounding and bonding of metal components associated with the pool in accordance with governing Electrical Codes.

### **1.03 REGULATORY AGENCY REQUIREMENTS AND ENGINEERING SERVICES**

- A. The system must comply with necessary pre-construction approvals.

- B. Give necessary notices, obtain permits, pay government fees, and other costs in connection with his work, including the filing of necessary as-built drawings, prepare documents (including any amendments to the approved construction documents) and obtain necessary approvals of governmental departments having jurisdiction over their work. Obtain required certificates of inspection for his work and deliver copies to the Owner and Consultant before requesting acceptance and final payment for the work.
- C. Include in the work, without extra cost to the Owner, labor, materials, services, apparatus, or drawings in order to comply with applicable laws, ordinances, rules, and regulations, whether or not shown on drawings and/or specified.

#### **1.04 COORDINATION AND CLARIFICATION**

- A. Coordinate with other trades' work relating to this section.
- B. Must establish with other trades, having related work in this section, that work necessary to complete the pool(s) as shown on the drawings and in the specifications is included in the base bid and alternates to the Owner.
- C. If in doubt regarding the responsibility for work covered in this section and/or discovery of errors or omissions in the bidding documents, notify the Consultant through channels established by the specifications and request a clarification ten (10) days prior to the bid date.

#### **1.05 ALTERNATES**

- A. Review the description of the alternates in Division 1 and on the drawings for possible effect upon work in this section. Alternates related to the work in this section are described in this division and on the bid proposal form.
- B. Pool Alternates – Refer to specification section 011100 for further information regarding working included/omitted from this contract as well as any add/deduct alternates.

#### **1.06 CONTRACTOR'S ALTERNATE PROPOSAL**

- A. Submit bid to the Owner based on materials, equipment and methods as specified in this Section.
- B. It is the intent of the contract documents to encourage competition. The base proposal must include the construction methods and equipment as specified and detailed. Proposed system substitutions must have prior written approval by the Consultant.
- C. If there is a deviation from the basis of design equipment, confirm that engineering criteria are appropriate for the substituted equipment.
- D. Substitutions of specified construction methods and equipment must include a complete submittal as required by these specifications and drawings of appropriate scale incorporating required changes. Provide a list of at least ten (10) satisfactory installations comparable to this project that have been manufactured and installed under the manufacturer's current legal name. Submit a list of such projects with the name, address and current telephone number of the Owner's Operator and Consultant of Record to the Consultant on the bid date.
- E. Changes or modifications to the Contract Documents that are not authorized by the Consultant are the sole responsibility of the Contractor.

#### **1.07 SUBMITTALS**

- A. Submittals must be made in accordance with the requirements of Division 1 - General Requirements and in strict compliance with the following procedures and guidelines.
- B. One (1) set of shop drawings and engineering data must be tabbed, indexed, and referenced to the specifications, compiled into an electronic submittal, and submitted in two stages. The first stage must include items for the pool shell(s), reference swimming pool structural specifications. The

second stage must be for remaining items. Each section of items must be prefaced by a cover sheet listing the items submitted within the section. Electronic submittals must be organized, numbered, and submitted in the same format and order as the project specifications. Only complete sets will be reviewed.

1. Engineering data covering systems, equipment, structures, and fabricated materials, which will become a permanent part of the work under this contract, must be submitted for review. This data must include drawings and descriptive information in sufficient detail and scale to show the kind, size, arrangement, and operation of component materials and devices; the external connections, anchorage and supports required; performance characteristics; fabrication and dimensions needed for installation and correlation with other materials and equipment. A certification, in writing, must be provided indicating that equipment will fit in the space allotted and as shown on the drawings.
2. Submittals regardless of origin must be stamped with the approval of the Contractor and identified with the name and number of this contract, Contractor's name, and references to applicable specification paragraphs and contract drawings. Each submittal must indicate the intended use of the item in the work. When catalog pages are submitted, applicable items must be clearly identified. The current revision, issue number, and date must be indicated on drawings and other descriptive data.
3. The submittals will not be accepted from anyone but the Contractor. Submittals must be consecutively numbered in direct sequence of submittal and without division by subcontracts or trades.
4. The Contractor's stamp of approval is a representation that the Contractor accepts full responsibility for determining and verifying quantities, dimensions, field construction criteria, materials, catalog numbers and similar data, and that he has reviewed or coordinated each submittal with the requirements of the work and the contract documents.
5. Each submittal must include a statement prepared by the originator of the drawings and data, certifying compliance with the contract documents except for deviations, which are specifically identified.
6. Deviations from the contract documents must be identified on each submittal and must be tabulated in the Contractor's letter of transmittal. Such submittals must, as pertinent to the deviation, indicate essential details of changes by the Contractor (including modifications to other facilities that may be a result of the deviation) and required piping and wiring diagrams.
7. The Contractor must accept full responsibility for the completeness of each submission, and, in the case of a resubmission, must verify that exceptions previously noted have been considered.
8. The need for more than one resubmission, or a delay in obtaining review of submittals, will not entitle the Contractor to an extension of the contract time unless the delay of the work is directly caused by a change in the work authorized by a change order.
9. Review of drawings and data submitted by Contractor will cover only general conformity to the drawings and specifications, external connections and dimensions that affect the layout. Review does not indicate a thorough review of dimensions, quantities, and details of the material, equipment, device, or item shown. Review of submittals does not relieve Contractor from responsibility for errors, omissions, or deviations, or responsibility for compliance with the contract documents.
10. When the drawings and data are returned marked REJECTED, REVISE AND RESUBMIT or SUBMIT SPECIFIED ITEM, the corrections must be made as noted thereon and as instructed and six corrected copies (or one copy and one corrected reproducible copy) resubmitted.

11. Resubmittals must bear the number of the first submittal followed by a letter (A, B, etc.) to indicate the sequence of the resubmittal. Resubmittals must be indexed, tabbed, referenced to the specifications, and bound in a three-ring binder and submitted at one time.
  12. When corrected copies are resubmitted, the Contractor must, in writing, direct specific attention to revisions and must list separately revisions made other than those called for on previous submissions.
  13. When the drawings and data are returned marked NO EXCEPTIONS TAKEN or MAKE CORRECTIONS NOTED, no additional copies are to be provided unless specifically requested to do so for record.
- C. Permits, Receipts and Test Reports
1. Provide the Consultant with copies of permits and receipts for fee payments.
  2. Submit a sample format for each test report intended for use. Submit test reports required herein only on approved forms.
- D. Include complete product data indexed, tabbed, and referenced to specifications with 8 ½" x 11" cover sheet covering:
1. Paragraph 2.01 - Filtration Equipment
  2. Paragraph 2.02 - Piping Systems
  3. Paragraph 2.03 - Chemical Treatment Systems
  4. Paragraph 2.04 - Flow Meters
- E. Reference Section 131105 - Selective Demolition

#### **1.08 OPERATION AND MAINTENANCE MANUALS AND CLOSE-OUT SUBMITTALS**

- A. Detailed operation and maintenance information must be supplied for equipment requiring maintenance or other attention. The equipment supplier and/or the Contractor must prepare an operation and maintenance manual for equipment. Parts lists and operating, and maintenance instructions must be provided.
- B. Each operation and maintenance manual must include the following:
1. Equipment function and calibration, normal operating characteristics, and limiting conditions.
  2. Assembly, installation, alignment, adjustment and checking instructions.
  3. Operating instructions for startup, routine and normal operation, regulation, and control, shut down and emergency conditions.
  4. One (1) copy of instructional videos.
  5. One (1) copy of Safety Data Sheet forms for all pool chemicals provided.
  6. Operating cycles must be specifically described in outline format and in referenced detail. A wall-mounted color-coded piping flow diagram must be provided in the pool equipment room. The diagram must be engraved on laminated plastic with color-coded piping to match the color of coding on piping, and including valves identified with number on tags. The minimum size is 11-inch x 17 inch.
  7. Include manufacturer recommended maintenance schedule, parts lists, piping diagram (to agree with wall mounted diagram) and trouble-shooting information for pool mechanical equipment.
  8. Using reference to keyed valves and wall diagram, include specific written instructions for procedures that must be followed for the following:

- a. Filter operation and backwashing; and
  - b. Super chlorination.
9. Lubrication and maintenance instructions.
  10. Guide to "troubleshooting."
  11. Parts list and predicted life of parts subject to wear.
  12. Outline, cross section, and assembly drawings; engineering data and wiring diagrams.
  13. Test data and performance curves, where applicable.
  14. Specific written instructions for procedure for emptying and refilling the pool(s) including de-watering during the period that the pool will be empty. Provide a yellow warning sign 8-1/2 in. x 11 in., that must be mounted in the pool mechanical room, that reads:

Keep Caps, Plugs and Tops Tight Fitting to Prevent Escape of Fumes.
15. Additionally, provide the following signs mounted on the chemical room doors:
    - a. NFPA Hazard Diamond for each chemical stored in room.
    - b. Warning: Authorized Personnel Only Beyond This Point
    - c. Signage indicating location of associated Safety Data Sheet forms for all chemicals stored in room.
  16. One set of applicable submittals must be included in each manual.
- C. The operation and maintenance manuals must be in addition to instructions or parts lists packed with or attached to the equipment when delivered, or which may be required by the Contractor.
  - D. Manuals and other data must be printed on heavy, first quality paper, 8-1/2 x 11-inch size with standard 3-hole punching and inserted in plastic covers. Drawings and diagrams must be reduced to 8-1/2 x 11 inches or 11 x 17 inches. Where reduction is not practical, larger drawings must be folded separately and placed in envelopes that are bound into the manuals. Each envelope must bear suitable identification on the outside.
  - E. Two (2) bound volumes of each manual must be submitted. Parts lists and information must be assembled in substantial manuals and permanent, three-ring or three-post binders. Material must be assembled and bound in the same order as specified, and each volume must have a table of contents and suitable index tabs.
  - F. Material must be marked with project identification. Non-applicable information must be marked out or deleted.
  - G. Shipment of equipment will not be considered complete until the required manuals and data have been received.

#### **1.09 PRODUCT DELIVERY, STORAGE, AND HANDLING**

- A. Deliver material in manufacturer's original, unopened containers and crates with labels intact and legible.
- B. Deliver materials in sufficient time and quantity to allow continuity of work and compliance with approved construction schedule.
- C. Handle materials in a manner to prevent damage.
- D. Store materials on clean raised platforms with weather protective coverings. Provide continuous protection of materials against damage or deterioration.
- E. Remove damaged materials from site.

### **1.10 WARRANTIES**

- A. The Contractor warrants to the Owner and Consultant that materials and equipment provided under the contract will be of good quality and new unless otherwise required or permitted by the contract documents, that the work will be free from defects not inherent in the quality required or permitted, and that the work will conform with the requirements of the contract documents. Work not conforming to these requirements, including substitutions not properly approved and authorized will be considered defective. The Contractor's warranty will exclude remedies for damage or defect caused by abuse, improper or insufficient maintenance, improper operations, modifications not executed by the Contractor or improper wear and tear under normal use. If required by the Consultant, provide satisfactory evidence as to the kind and quality of materials and equipment.
- B. The Contractor must agree to repair or replace defective or non-complying work at no cost to the Owner upon written notification from the Owner within the warranty period. Pro-rated warranties are not acceptable.
- C. Warranties must be for a period of one year from the date of substantial completion or the owner begins using the pool unless otherwise specified. Submit warranties covering, but not limited to the following:
  - 1. Defects in material, manufacture and installation of the backwash, chlorination, and pH adjustments, including controls for a period of one (1) year.
  - 2. Manufacturer's minimum fifteen (15) year warranty on the filter tank against defective materials or workmanship of the tank and components. Prorated warranties are not acceptable
  - 3. Defects in material, workmanship, and installation of the pool piping system for a period of three (3) years.
  - 4. Manufacturer's minimum one (1) year warranty against defective materials, components, and workmanship in the sanitizing feed system.
  - 5. Manufacturer's minimum one (1) year warranty against defective materials, components, and workmanship in the pH buffer feed system.
  - 6. Manufacturer's minimum three (3) year warranty against defective materials, components, and workmanship in the Clear-Flow Electronic Flocculation System (EFS).

### **1.11 SYSTEM TRAINING**

- A. A qualified representative of the Contractor performing work under this section must put the equipment into operation and instruct the Owner's representatives in the operation of this equipment to the Owner's satisfaction immediately after project's substantial completion.
- B. The Contractor's training representative must have completed the equipment/system's manufacturer's training requirements and be certified, by the manufacturer, to provide and teach system training.
- C. The representative from the Contractor must be either a CPO (Certified Pool Operator) or have an AFO (Aquatic Facility Operator) certification.
- D. Two on-site trainings must be provided by the Contractor with dates and times coordinated with the Owner. Training must be scheduled as follows:
  - 1. Training on the renovated swimming pool equipment and water chemistry analysis / adjustment. The water chemistry training will include in-depth review of the use of the Langlier index and its computation.
  - 2. Training must include information on the care, operation, adjustment, and maintenance of items provided by the Contractor under the "Part 2 – Products" section of this specification.

3. Provide a project specific video recording instruction manual in addition to the training sessions. The video instructions must be project specific and must include information on the care, operation, adjustment, and maintenance of items provided by the Contractor under the "Part 2 – Products" section of this specification. This video recording must be done separate from the Owner training.
4. The Contractor must include one (1) copy of video recording instructions in each Operations and Maintenance Manual.

#### **1.12 POOL FILL WATER QUALITY**

- A. The Owner is to bear the cost of the water required for one (1) complete filling of the pool (the final filling). Removal of iron or copper (if in excess of .3 ppm) will be required for the final fill to avoid staining of the pool finish. Subsequent fillings or partial fillings (more than 25%) of the pool is by the Contractor, at its own expense.
- B. Fill water must be within plus or minus 10 degrees of the ambient air and/or the pool structure at the time of filling. Extreme caution is urged if the temperature variance is greater than 10-degree F.
- C. Provide the necessary chemicals and to adjust and balance the water chemistry in the pools to the following levels:

pH	7.4 - 7.6
Calcium Hardness	200 - 400 PPM
Total Alkalinity	60 - 80 PPM
Langelier saturation index	-0.3 - +0.3
Total Dissolved Solids (TDS)	not to exceed 1,500 PPM

#### **1.13 START-UP CHEMICALS**

- A. The Contractor must maintain the chemical balance of the pool water (including the cost of chemicals required) until the pool and mechanical system(s) are fully operational and accepted by the Consultant and the Owner.
- B. Provide the Owner with sufficient quantities of the necessary chemicals to maintain the pool operation after the owner begins using the pool.
  1. The Contractor is required to provide chemical quantities as shown on the drawings for the following chemicals:
    - a. Calcium Hypochlorite
    - b. Sodium Bisulfate
- C. Chemicals must be provided to the Owner must include those required by the chemical feed systems provided.

#### **1.14 RECORD DRAWINGS**

- A. Provide a complete set of record drawings of the renovated pool system. Record drawings must be a complete, stand-alone set. The Contractor is permitted to obtain original documents and copy them for this purpose only.

### **PART 2 - PRODUCTS**

#### **2.01 FILTRATION EQUIPMENT**

- A. The filter system must consist of high-rate pressure sand filter tanks as shown on the drawings. Every aspect and component of the filter system must be certified by the National Sanitation Foundation (NSF) and bear the certification mark. The filter must have an engraved metal data

plate permanently affixed on the face of the system that describes operational data and instructions and indicates startup date.

- B. It is the intent of these specifications to describe a filtration system complete in every respect with accessory items and supplied and warranted by one manufacturer.
- C. Horizontally Oriented Fiberglass Tank(s) (Leisure Pool, Hot Tub, and Competition Pool)
  - 1. The filter tanks must be horizontally oriented single cell fiberglass tanks, minimum 36 inches in diameter. The filter system must be listed as approved by the National Sanitation Foundation prior to bid date.
    - a. Basis of Design: Fiberglass filters must be the product of Stark/Pentair, Waterco, Neptune Benson, or approved equal provided they meet the specifications and layout. System design is based upon Neptune-Benson. Valves must be provided to backwash one filter at a time.
  - 2. Filter tanks must incorporate components and features as described in this section.
  - 3. Two (2) saddle style bases must be provided for tank support. Systems that incorporate stacked tanks must include similar bases and mounting saddles for the upper vessel. Tank supports and connections must be seismic rated to support the filter tank(s) for the appropriate seismic zone where the project is located. Access to the tank must be provided by a 14" x 18" manhole with two (2) curved yokes. Manhole seal must be complete with a one-piece 1/4" neoprene gasket and positioned so that internal pressure from the filter will augment the seal. No additional hardware or through bolts will be allowed.
  - 4. Each filter tank must be equipped with the necessary flanges and connections for the internal and external piping. Connections must be comprised of fiberglass flanges and schedule 80 PVC flanges.
  - 5. Tank connections 2 inches and smaller must be 150 lb. Type 316L stainless-steel threaded full couplings. Tank connections 3 inches and larger must be heavy steel bosses drilled and tapped on both sides to receive standard flanged fittings or Sch. 40 Type 316L stainless-steel nipples.
  - 6. The discharge from the automatic air release valve must be hard piped to waste. Each filter tank must have a means of releasing air. Each coupling or orifice must be provided with a slotted PVC sand retainer or stainless-steel strainer. An automatic air release system must be provided for each tank.
  - 7. The drain system must consist of a 3/4-inch 316L stainless-steel coupling mounted at the lowest point in the bottom head. This drain must be valved and piped to the nearest floor drain or backwash pit.
  - 8. Filter Piping - Internal
    - a. The lower internal distribution system must be a horizontal header/lateral arrangement. The header must be Schedule 80 PVC construction, capped on one end and flanged or threaded at the other end for field connection. Lateral connections must be spaced no more than 6 inches on centers and must be 1-1/2-inch FPT connections. Attachments to header must be solvent welded and thermo-welded to ensure integrity of connection.
    - b. Under drain system must be factory installed and constructed of extra heavy Schedule 80 high impact PVC. Multiple PVC main headers must be tapped and threaded to receive laterals.
    - c. Laterals must consist of 1-1/2-inch Schedule 80 PVC pipe with openings as required. Each lateral must be fabricated complete with socket cap on one end and male adapter on the other end. Both fittings must be solvent welded to the slotted pipe.

- Laterals must be designed and sized at the factory, so they are installed in the field and over the entire cross sections area of the filter.
- d. The upper distributor must consist of PVC piping Schedule 80 and/or deflector plate per manufacturer standard design.
  - e. Each filter must be supplied with a pressure equalizing upper internal distribution system consisting of a horizontal header/lateral arrangement. The header piping must be constructed of Schedule 80 PVC. The header/lateral piping and connections must be designed and sized to provide uniform distribution and unrestricted flow during the filtration and backwash cycles.
  - f. Upper laterals must be constructed of Schedule 80 PVC pipe with machine slotted openings or orifices. Machined slots or orifices must be clean, de-burred and free of obstructions that would not permit the free flow of water through the opening. Details of the lateral attachment to the header must be submitted for review and approval.
  - g. The lower and upper distribution systems must be properly supported and anchored. Hardware in wetted areas must be Type 316L stainless-steel or non-metallic. Tank interiors must be inspected prior to the media being placed in the filters.
9. Filter Piping - External (Face)
- a. External face piping must be Schedule 80 PVC pipe and fittings. Flanges must be located so as to allow for easy dismantling of face piping. Fittings must be solvent cemented.
  - b. Piping must be drilled and tapped where necessary to accommodate gauge tubing connectors.
  - c. Valves 3" and larger must be constructed with cast aluminum S12A alloy (as defined by ASTM B275) housing and fully coated with Rilsan on interior and exterior surfaces. Internal components include EPDM resilient lining, Rilsan coated ductile iron disc and 316L stainless-steel shaft. Valves must be rated for 150 psi bubble tight shutoff. Unless otherwise specified, nuts and bolts must be stainless-steel with stainless-steel washers and used when secured to PVC flanges. Systems incorporating solenoid, pneumatic, pressure amplified, hydraulic or multi-directional valves are not acceptable.
  - d. Standard accessory items must include sight glass rated for 50 psi with polycarbonate glass, remote mounted gauge panel with two 4½" diameter pressure gauges, ¼" petcocks, ¼" poly vent tubing with PVC compression adapters.
10. Backwash Control
- a. The filter manifold face piping must be designed to allow for one (1) filter tank to backwash at a time while the recirculation system is operating. A manual backwashing system must be provided with the filter system.
  - b. Manual Backwash System
    - 1) The manual backwash system must be equipped with a face piping configuration such that the operator must manually control and operate both the time and sequencing of the backwash cycle. Valving on the filter face piping must be a mechanical linkage device allowing the operator to simultaneously move two (2) valves at once. Mechanical linkage components must be PVC or Type 316L Stainless-steel.
11. Automatic Air Relief Valve
- a. A 1" valve must be provided to automatically and continuously release air in the filter. The valve must be fabricated of plastic with Buna-N seals. A plumbing kit must be

provided with two (2) PVC ball valves to allow manual air relief and isolation of the automatic valve. Valves fabricated of cast iron, bronze or stainless-steel valves will not be accepted.

12. Filter Media (Sand)

- a. Filter media must be a carefully selected grade of hard uniformly graded silica material. Media must be milled angular shaped particles of silica quartz. The filter sand must have a particle size between 0.45 mm and 0.55 mm and have a uniformity coefficient not to exceed 1.53. Specific gravity must not be less than 2.5 with a pH of 7.0.
- b. Media (sand) must be cleaned and free from clay or limestone deposits. The bottom layer of support media must be placed by hand to avoid damage to the under-drain system and leveled before the addition of the upper layer of filter media.
- c. Media must be delivered after approval by the manufacturer of the filter and stored in 100-pound bags for ease of handling and elimination of possible contamination.
- d. Media must be supplied by the filter manufacturer and approved by the filter manufacturer prior to shipping.

13. Support Media

- a. A gravel support media of a hard-coarse aggregate with a sub-angular grain shape with a particle size of 1/8" x 1/4" must be used on the inside of the bottom head to the elevation where the filter media commences. The specific gravity must not be less than 2.5. Support media must be placed by hand to avoid damage to the underdrain system and leveled before the addition of the upper layer of filter media. Concrete under fill is not recommended. Support gravel must be delivered and stored in 100-pound bags (approximately one cubic foot) for ease of handling and elimination of possible contamination. Media must be free from minerals which can precipitate onto pool surfaces.
- b. Sand must be a carefully selected grade of hard, uniformly graded silica material. Media must be naturally rounded particles of silica or milled angularly shaped particles of silica quartz. Sand must have a particle size between 0.45mm and 0.55 mm (#20). No more than 1.5% is allowed to pass through a #40 sieve (.0164"). Uniformity coefficient must not exceed 1.53. Specific gravity must be not less than 2.5. The filter must contain a minimum bed depth as recommended by the manufacturer. Systems which do not provide a minimum bed depth will not be accepted. Sand must be delivered and stored in 100-pound bags (approximately one cubic foot) for ease of handling and elimination of possible contamination. Media must be free from minerals which can precipitate onto pool surfaces.

D. Vertically Oriented Fiberglass Tank(s) (Tot Pool)

1. The filter tanks must be vertically oriented single cell fiberglass tanks. The filter system must be listed as approved by the National Sanitation Foundation for the filter rate specified prior to bid date.
  - a. Basis of Design: Fiberglass filters must be the product of Hayward, Waterco, Neptune Benson, or approved equal provided they meet the specifications and layout. Valves must be provided to backwash one filter at a time.
2. The system must be supplied completely by the manufacturer and must include internals, face piping and valves, sight glass, air relief connection and bottom drain connection with internal strainer.
3. The filter tank must be suitable for 50 psi working pressure and designed with a 4:1 safety factor.

4. A base must be provided for tank support. Tank supports and connections must be seismically rated to support the filter tank for the appropriate seismic zone where the project is located.
5. Access to the tank must be provided by a manhole. The manhole seal must be one-piece and positioned so that internal pressure from the filter will augment the seal.
6. Each filter tank must be equipped with the necessary flanges and connections for the internal and external piping. Connections must be comprised of fiberglass flanges and schedule 80 PVC flanges.
7. The discharge from the automatic air release valve must be hard piped to waste. Each filter tank must have a means of releasing air. Each coupling or orifice must be provided with a slotted PVC sand retainer or stainless-steel strainer.
8. The filter must be provided with a drain system mounted at the lowest point in the bottom head. This drain must be valved and piped to the nearest floor drain or backwash pit.
9. Filter Piping - Internal
  - a. The header must be Schedule 80 PVC construction, capped on one end and flanged or threaded at the other end for field connection. Lateral connections must be spaced no more than 6 inches on centers and must be 1-1/2-inch FPT connections.
  - b. Underdrain laterals must consist of schedule 80 PVC pipe. Machined openings must be designed to retain all media particles as small as 0.30 mm particle size.
  - c. Overdrain laterals must consist of schedule 80 PVC pipe. Overdrain laterals must be designed to provide uniform distribution and unrestricted flow during filter and backwash cycles.
  - d. Each filter must be supplied with a pressure equalizing upper internal distribution system consisting of a horizontal header/lateral arrangement. The header piping must be constructed of Schedule 80 PVC. The header/lateral piping and connections must be designed and sized to provide uniform distribution and unrestricted flow during the filtration and backwash cycles.
  - e. The lower and upper distribution systems must be properly supported and anchored. Hardware in wetted areas must be Type 316L stainless-steel or non-metallic. Tank interiors must be inspected prior to the media being placed in the filters.
10. Filter Piping - External (Face)
  - a. External face piping must be Schedule 80 PVC pipe and fittings. Flanges must be located so as to allow for easy dismantling of face piping. Fittings must be solvent cemented.
  - b. Piping must be drilled and tapped where necessary to accommodate gauge tubing connectors.
  - c. The valve body must be constructed of ABS with EPDM o-ring seal and Kynar spider gasket. 3" valves must have socket connections.
  - d. Standard accessory items must include sight glass rated for 50 psi with polycarbonate glass, remote mounted gauge panel with two 4½" diameter pressure gauges, ¼" petcocks, ¼" poly vent tubing with PVC compression adapters.
11. Backwash Control
  - a. The filter manifold face piping must be designed to allow for one (1) filter tank to backwash at a time while the recirculation system is operating.
  - b. Manual Backwash System

- 1) A mechanical linkage must connect two (2) valves in order to create simultaneous movement. Connecting pieces must vary with the size of face piping in order to operate with suitable mechanical advantage. All linkage parts must be T304L stainless steel.
- 2) Linkage must be designed so that filter and backwash cycles can be accomplished by repositioning two (2) pairs of valves. Each pair of valves must be operated as specified with lever, gear, or electric actuation.
- 3) All linkage components must be grit blasted to a 1-2 mil profile. All linkage components must be finish coated with 3-4 mils DFT of Type 316 pigmented stainless-steel paint.

12. Filter Media

- a. Filter media must be a carefully selected grade of hard uniformly graded silica material. Media must be milled angular shaped particles of silica quartz. The filter sand must have a particle size between 0.45 mm and 0.55 mm and have a uniformity coefficient not to exceed 1.53. Specific gravity must not be less than 2.5 with a pH of 7.0.
- b. Media (sand) must be cleaned and free from clay or limestone deposits. The bottom layer of support media must be placed by hand to avoid damage to the under-drain system and leveled before the addition of the upper layer of filter media.
- c. Media must be delivered after approval by the manufacturer of the filter and stored in 100-pound bags for ease of handling and elimination of possible contamination.
- d. Media must be supplied by the filter manufacturer and approved by the filter manufacturer prior to shipping.

13. Support Media

- a. A gravel support media of a hard-coarse aggregate with a sub-angular grain shape with a particle size of 1/8" x 1/4" must be used on the inside of the bottom head to the elevation where the filter media commences. The specific gravity must not be less than 2.5. Support media must be placed by hand to avoid damage to the underdrain system and leveled before the addition of the upper layer of filter media. Concrete under fill is not recommended. Support gravel must be delivered and stored in 100-pound bags (approximately one cubic foot) for ease of handling and elimination of possible contamination. Media must be free from minerals which can precipitate onto pool surfaces.
- b. Sand must be a carefully selected grade of hard, uniformly graded silica material. Media must be naturally rounded particles of silica or milled angularly shaped particles of silica quartz. Sand must have a particle size between 0.45mm and 0.55 mm (#20). No more than 1.5% is allowed to pass through a #40 sieve (.0164"). Uniformity coefficient must not exceed 1.53. Specific gravity must be not less than 2.5. The filter must contain a minimum bed depth as recommended by the manufacturer. Systems which do not provide a minimum bed depth will not be accepted. Sand must be delivered and stored in 100-pound bags (approximately one cubic foot) for ease of handling and elimination of possible contamination. Media must be free from minerals which can precipitate onto pool surfaces

**2.02 PIPING SYSTEMS**

A. General

1. Provide recirculating piping between the pool(s) and the pool mechanical room, fill funnel and all interconnecting piping to and from the chemical feed systems and chemical controller.

2. Provide necessary pipe supports and support systems required to support associated piping and valves.
3. Provide other tubing, conduit or piping associated with equipment specified herein. Coordinate with other trades.

B. Pipes

1. Pipe routing as shown and detailed on the contract drawings is diagrammatic only and is not intended to show minor details or exact locations of piping systems. Installation is required and must be adjusted to accommodate interference and adjustments anticipated and encountered. Pipe sizes on plans refer to the nominal inside diameter of the pipe.
2. PVC swimming pool piping must be NSF approved and conform to the requirements of ASTM D-1785.
3. PVC pipes must be the product of one manufacturer. Approved manufacturers of PVC piping are Eslon, Harvel, and Chemtrol or approved equal.
4. The swimming pool piping must be Schedule 80 PVC.
5. PVC fittings must be the product of one manufacturer. Molded fittings must be manufactured by Ipex, Chemtrol, Harvel, Spears, and Lasco/Westlake or acceptable substitutes. Fabricated fittings must be manufactured by Harrison Machine, Spears, or an acceptable substitute.
6. Chemical feed lines from chemical feeders to recirculation piping must be Schedule 80 PVC piping. Piping must be hard piped into the recirculation piping via tee or saddle per the drawings. Required valves must be of PVC construction.
7. Flanged plumbing connection hardware must be stainless-steel.
8. Materials must be installed by workmen thoroughly skilled in their trades and work must present a neat and mechanical appearance when complete. At no additional expense to the Owner, replace or correct work not judged acceptable by the Consultant, Engineer, or Owner's representation.
9. No installation allowed that will provide a cross-connection or interconnection between a distributing supply for drinking purposes and the swimming pool, or between the pool and a sanitary or storm water sewer system that will permit a backflow of water into the pool water system.
10. Piping must be hydrostatically (water) pressure tested for leaks to guarantee water tightness. Pneumatic (air) pressure test is not allowed.
11. Mechanical equipment must be connected into the recirculation piping system must be connected utilizing flanged or union connections.
12. Concentric reducers must be fiberglass by MerMade Filter, Inc., or equivalent reducers of schedule 80 PVC construction.

C. Pipe Hangers and Supports

1. Manufacturer
  - a. Subject to compliance with these specifications, pipe hanger and support systems must be manufactured by Cooper B-line (basis of design), Inc, TOLCO, and Anvil International or approved equal.
2. Hangers
  - a. Pipes 2 inches and smaller
    - 1) Adjustable steel clevis hanger, B-Line models B3100 or B3104.

- 2) Adjustable steel swivel ring (band type) hanger, B-Line model B3170.
    - b. Pipes 2-1/2 inches and larger
      - 1) Adjustable steel clevis hanger, B-Line model B3100.
      - 2) Adjustable steel yoke pipe roll, B-Line model B3114.
  3. Multiple or Trapeze Hangers
    - a. Trapeze hangers must be constructed from 12-gauge roll formed ASTM A1011 SS, Grade 33 structural steel channel, 1-5/8 by 1-5/8-inch minimum, B-Line B22 strut or stronger as required.
    - b. Mount pipes to trapeze with 2-piece pipe straps sized for outside diameter of pipe, B-Line B-2000 series.
  4. Wall Supports
    - a. Pipes 2-1/2 inches and smaller
      - 1) Steel offset "J" hook hanger, B-Line model B3600.
    - b. Pipes 3 inches and larger
      - 1) Welded strut bracket and pipe straps, B-Line models B3064 and B2000 series.
      - 2) Welded steel bracket B-Line model B3066 or B3067 with roller chair or adjustable steel yoke pipe roll. B-Line model B3120 or B3110.
  5. Floor Supports
    - a. Electroplated carbon steel adjustable pipe saddle and nipple attached to steel base stand sized for pipe elevation. B-Line model B3092 and B3088T or B3090 and B8088. Pipe saddle must be screwed or welded to an appropriate base stand.
  6. Vertical Supports
    - a. Steel riser clamp sized to outside diameter of pipe, B-Line model B3373.
  7. Plastic Pipe Supports
    - a. V-Bottom clevis hangers with galvanized 18-gauge continuous support channel, B-Line models B3106 and B3106V, to form a continuous support system for plastic pipes smaller than 1 inch or flexible tubing.
    - b. A vented and sloped continuous PVC Schedule 40 pipe no smaller than 1-1/2 inch outside diameter will be used to route flexible tubing with the appropriate pipe supports.
  8. Supplementary Structural Supports - Design and fabricate supports using structural quality steel bolted framing materials. Channels must be roll formed, 12-gauge ASTM A1011 SS Grade 33 steel, 1-5/8 inch or greater as required by loading conditions. Submit design for pipe tunnels, pipe galleries etc. for approval. Use clamps and fittings designed for use with the strut system.
- D. Hanger Attachments
1. Upper Attachments
    - a. Beam Clamps
      - 1) Beam clamps must be used where piping must be suspended from building steel. Clamp type must be selected on the basis of load supported and load configuration.

- 2) C-Clamps must be locknuts and cup point set screws similar to B-Line model B351L or B3036L. Top flange c-clamps must be used when attaching a hanger rod to the flange of structural steel, B-Line model B3034 or B3033 or approved equal. Refer to manufacturer's recommendations for set screw torque. Retaining straps must be used to maintain the clamp position on the beam where required.
- 3) Center load beam clamps must be used where specified. The steel clamps must be B-Line models B3050 or B3055. Forged steel beam clamps with cross bolt must be B-Line B3291-B3297 series or approved equal as required to fit beams.

b. Concrete Inserts

- 1) Cast in place spot concrete inserts must be used applicable, either steel or malleable iron body, B-line B2500 or B3014 or approved equal. Spot inserts must allow for lateral adjustment and have means for attachment to forms. Select inserts to suit threaded hanger rods sizes, B-line models N2500 or B3014N series.
- 2) Continuous concrete inserts must be used where applicable. Channels must be 12 gauge, ASTM A1011 Grade 33 structural quality carbon steel, complete with Styrofoam inserts and end caps with nail holes for attachment to forms. The continuous concrete insert must have a load rating of 2,000 lbs/ft. in concrete, B-Line models B22I, 32I, or 52I or approved equal. Select channel nuts suitable for strut and rod sizes.

E. Hanger Accessories

1. Hanger rods must be threaded on both ends or continuously threaded rods of circular cross section. Use adjustable lock nuts at upper attachments and hangers. No wire, chain, or perforated straps are allowed.

F. Hanger Finish

1. Indoor Finishes
  - a. Hangers must be zinc plated in accordance with ASTM B633 or must have an electro-deposited green epoxy finish.
  - b. Strut channels must be pre-galvanized in accordance with ASTM A653 SS Grade 33 G90 or must have an electro-deposited green epoxy finish.
  - c. Zinc Plated hardware is not acceptable for use in chemical rooms.

G. Valves

1. Valves 3 inches and larger must be butterfly type valves, with PVC body, 150# SWP with stainless-steel shaft, PVC or polypropylene disc and replaceable resilient seat bonded to a rigid shaft and guaranteed for bubble tight shutoff from 27-inch vacuum to 150 PSI. Extended neck 2 inches beyond flanges for insulated piping must be provided with handle for manual operation. Valve components must be suitable for swimming pool chlorinated water service. Butterfly valves must be Georg Fischer Type 567, Asahi/America Type SP Pool-Pro, Chemtrol Model-B, Simtech VP series, Colonial Valve 411 Series, or approved equal.
2. Valves smaller than 3 inches must be PVC true union ball valves, full port, three-piece construction, blowout-proof stem, Viton seal with socket end connectors.
3. Butterfly type valves 8 inches and larger must be fitted with a watertight gear operator.
4. Valves located 7 feet or greater off the floor must be fitted with a chain operator.

5. Valve hardware must be 316L stainless-steel and meet ANSI hardware installation guidelines.

H. Pipe and Valve Identification

1. New exposed pool piping must be equipped with color coded flow directional arrows at intervals per local swimming pool health code. Verify that pool piping identification is in accordance with governing health regulations.
2. New valves must be identified with minimum 1-1/2-inch diameter plastic laminate engraved tags with minimum 1/2-inch-high numbers. Tags must be fastened to valves with a nylon attachment (zip tie). Valves must be described as to their function and referenced in the operating instruction manual and wall mounted piping diagram that must be prepared.

**2.03 CHEMICAL TREATMENT SYSTEMS**

A. Calcium Hypochlorite (Chlorine Tablets)

1. Shop drawings complete with a piping diagram depicting the location in which the dry chlorination feeder is connected to the system must be provided and approved prior to installation. Installation of the system must be as specified in the manufacturer's directions with no exceptions taken.
2. A factory-authorized representative must provide training to the owner and the training must be video recorded.
3. Accu-Tab PowerBase
  - a. General Description
    - 1) The system must be designed to feed low concentrations of calcium hypochlorite in solution intermittently or continuously as required for pool applications. The system must be a single pre-assembled, package unit with a welded aluminum frame consisting of chlorinator, electrical box, centrifugal pump, and solution tank for ease of installation and operation. The system must be the Accu-Tab PowerBase. Only Accu-Tab Blue SI calcium hypochlorite tablets must be used, the patented blue colorant added for safety (to help prevent accidental mixing with other chemicals).
    - 2) The system must use an NSF Standard 50 listed erosion feeder and tablet combination and must be capable of meeting the requirements of the Health Department having jurisdiction over the installation.
  - b. System Features
    - 1) A maximum chlorine solution level of 0.05% (500 ppm) must be maintained to prevent calcification in system components. Systems producing chlorine concentrations higher than 0.05% are not acceptable.
    - 2) Delivery must be by erosion feed technology to control accurate and consistent concentration limits in the chlorine treatment solution. Soaking type, spray, and/or vortex technology systems are not acceptable.
    - 3) The chlorinator must automatically and continuously feed a limited quantity of chlorine in solution as needed; when the system is not running, no more chlorine than that amount which can be fed in one minute or less must be left in the tank to prevent dilution. Batch systems preparing excess quantities of solution for delivery over an extended period are not acceptable.
    - 4) A centrifugal pump wired to the system electrical box must feed freshly mixed chlorine treatment solution only as required for maximum efficiency. Batch

systems requiring the use of a metering pump or pumps to feed pre-prepared standing solution are not acceptable.

- 5) Piping in the chlorinator unit must be Schedule 40 PVC. Systems with flexible tubing are not acceptable.

c. System Components

- 1) Accu-Tab PowerBase chlorinators are designed exclusively for Accu-Tab Blue SI calcium hypochlorite tablets. Tablets are placed on a sieve plate inside the chlorinator; as water flows across the sieve plate, the tablets erode at a rate proportional to the flow rate.
- 2) Inlet Water Supply Connection.
  - a) Model 1030: 1.5" (water supply of 10 GPM required)
- 3) Inlet Water Filter: A filter to protect chlorinator components from start-up debris and sand from broken filter laterals.
- 4) Flow Meter:
  - a) A rotameter flow meter, measuring the flow of the water-eroding stream to the chlorinator.
- 5) Solution Tank: Made of PVC.
- 6) Capacities:
  - a) Model 1030: 7 gallons
- 7) Primary Solution Tank Level Control: Made from Schedule 80 PVC and 316L stainless-steel. The float valve opens to maintain the pump rate as it is manually throttled.
- 8) Overflow Protection: Two (2) level switches in the upper portion of the solution tank will run the pump from high to lower level to prevent system overflow.
- 9) Solution Delivery Pump: Delivers chlorinated solution to the return line. A single-stage centrifugal pump is provided for systems with pressures up to 20 PSIG.
- 10) Primary Backflow Prevention: A PVC swing check valve prevents reverse flow of water into the system.
- 11) Discharge Control Valve (manual): PVC gate valve allows operator to adjust flow of solution to the system.
- 12) Outlet Connection:
  - a) Model 1030: 1"
- 13) Aluminum Frame: Type 6061-T.
- 14) NEMA 4X Electrical Enclosure

B. pH Buffering System (Dry Acid)

1. Shop drawings complete with a piping diagram depicting the location in which the dry acid feeder is connected to the system must be provided and approved prior to installation. Installation of the system must be as specified in the manufacturer's directions with no exceptions taken.
2. Acid Rite
  - a. General Description

- 1) The system must be designed to erode Acid-Rite tablets, creating an acid solution, and feeding the solution intermittently or continuously as required for pool applications. The system must be a single pre-assembled, package unit with a welded aluminum frame consisting of an Acid-Rite feeder, electrical box, centrifugal pump, and balance tank for ease of installation and operation. The system must be the Acid-Rite pH Adjustment System by Axiall, a Westlake Company. Only Acid-Rite Tablets by Axiall must be used with a red colorant added for safety (to help prevent accidental mixing with other chemicals).
  - 2) The system must use an NSF Standard 50 listed erosion feeder and tablet combination and must be capable of meeting the requirements of the Health Department having jurisdiction over the installation.
- b. System Features
- 1) Delivery must be by erosion feed technology for accurate control of acid addition. Soaking type, spray, and/or vortex technology systems are not acceptable.
  - 2) The acid feed system must automatically and continuously feed a limited quantity of acid solution as needed. When the system is not running, no more acid solution than that amount which can be fed in 2 minutes or less must be left in the tank to prevent dilution. Batch systems preparing excess quantities of solution for delivery over an extended period are not acceptable.
  - 3) A centrifugal pump wired to the system electrical box must feed freshly mixed acid solution only as required for maximum efficiency. Batch systems requiring the use of a metering pump or pumps to feed pre-prepared standing solution are not acceptable.
  - 4) Piping in the acid feed system must be Schedule 80 PVC. Systems with flexible tubing are not acceptable.
- c. System Components
- 1) Acid Feeder: Acid-Rite feeders by Axiall are designed exclusively for Acid-Rite tablets by Axiall. Tablets are placed on a plate inside the feeder; as water flows across the plate, the tablets erode at a rate proportional to the flow rate. The lid color must be red, matching the pail lid color to avoid mixing chemicals.
  - 2) Inlet Filter: A filter is included to prevent debris from entering the float valve.
  - 3) Inlet Water Supply Connection: 1" Socket (water supply of 10 GPM required).
  - 4) Solution Tank Capacity:
    - a) Model 450: 6 gallons
  - 5) Primary Solution Tank Level Control: Made from Schedule 80 PVC and 316L stainless-steel, this 1" float valve meters the flow through the feed system. The float valve opens or closes to maintain the pump rate as it is manually throttled.
  - 6) Solution Delivery Pump: Delivers acid solution to the aquatic system return line. A single-stage centrifugal pump is provided for systems with pressures up to 20 PSIG.
  - 7) Solution Injection Pump Air Bleed: Used to prime the pump at start-up.
  - 8) Flow Meter: A flow meter, measuring the flow of the water-dissolving stream through the feed system.

- 9) Primary Backflow Prevention: A PVC check valve prevents reverse flow of water into the system.
- 10) Discharge Flow Control Valve (manual): PVC gate valve allows operator to adjust flow of solution to the pool system.
- 11) Overflow Port: A 1" FPT port is located on the back side of the feeder solution tank.
- 12) Stacking Cartridge:
  - a) Model 450: Utilizes a stacking cartridge that allows 1-7 stacks of tables to permit control of lower delivery rates.
- 13) Outlet Connection: 1"
- 14) NEMA 4x Electrical Enclosure
- 15) Aluminum Frame: Type 6061-T.

C. Electronic Flocculation System

1. The Clear-Flow Electronic Flocculation system must be provided and installed on the recirculation piping for the swimming pools and hot tub. The Clear-Flow system must be a non-chemical water treatment system designed to operate as an electronic flocculant in recreational water systems. When implemented into the system, the Clear-Flow system must work to agglomerate both organic and mineral particulate resulting in filtration enhancement on all types of filtration systems. This filtration enhancement must allow for a reduction in backwashing frequency - saving water, chemicals, and energy.
2. The Clear-Flow system must be UL listed and certified to NSF/ANSI Standard 50 and documentation of such certification must be provided by the manufacturer with each system.
3. When used in a recreational water application, the Clear-Flow system must work as an electronic flocculant. By generating and propagating a low-frequency treatment signal throughout the entire plumbing system, the technology must produce an ongoing flocculation effect which will aid in a reduction in turbidity and improved clarity.
4. The Clear-Flow system's ongoing flocculation effect must enhance filtration efficiency. The flocculation effect must create larger particles allowing for a reduction in both frequency and duration of backwashing.
5. Equipment
  - a. The following components are contained in a standard Clear-Flow kit and must be provided for each system:
    - 1) ABS or SS enclosure with 3 glands (2 for signal leads and 1 for power supply)
    - 2) Signal cables complete with mounting tags (Temp. rating -40°F to +140°F) (Qty. 2)
    - 3) Stainless steel hose clamps (Qty. 4)
    - 4) Gland plug (Qty. 1)
    - 5) 2A / 250 VAC UL-listed slow blow fuse (Qty. 1)
    - 6) 4mm Allen wrench (for grub screw) (Qty. 1)
6. Clear-Flow electronic flocculation system models must be the following:
  - a. For pipes up to 3": Model # CF-300C
  - b. For 4" pipes: Model # CF-400

- c. For 6" pipes: Model # CF-600
  - d. For 8" pipes: Model # CF-800
  - e. For 10" pipes: Model # CF-1000
7. Power Requirements:
- a. Input Voltage: 100–240 VAC
  - b. Input Frequency: 50 - 60 Hz
  - c. Power Rating: 4W for CF-300C, 5.4W for all other models
  - d. Internal Fuse Rating: 2A / 250VAC UL-Listed slow-blow
  - e. Temperature Range: -40°F to +140°F
  - f. The electrical supply must be properly grounded, or the system will not work. Hard wiring is preferred to avoid accidentally unplugging the unit.
  - g. All safety-critical components must conform to relevant CE/IEC/UL 60950. E235235. Terminals, wires, fuse, on/off switch, AC/DC PSU. PSU must be Class II protected.
  - h. Armored 2 Core Cable:
    - 1) Spec. BC 6883; 1999
    - 2) IEC 600332 –3—22 Category A
    - 3) Temperature rating - 22°F to +140°F
    - 4) ISO 9001 – 2008 Approved
8. Installation
- a. To ensure proper start-up of equipment the Contractor must consult a Clear-Flow representative.
  - b. Optimal results are achieved if the Clear-Flow system is connected to a grounded power outlet (100-240 VAC, 50-60 Hz, 4-amp) that shares the same ground as the recirculation system the unit is being installed on.
  - c. The Clear-Flow system must come with two identical signal cables. One is intended as the "T" (transmit) signal connection, the other is intended as the "A" (antenna) signal connection. The "T" signal tag must be installed downstream from the pump and before the filter. It is preferred that the "T" signal tag is mounted on a metal reducer or stainless-steel spool piece downstream of the pump. Alternative installation points for the "T" signal tag can be to mount it on a metal valve, the downstream flange of the pump (if metallic), or a stainless-steel spool piece that would provide a metal-to-water path for the treatment signal to propagate into and throughout the pool's recirculation system. The "A" tag must be mounted on a metal structure that is electrically connected to the system loop, which may include but is not limited to a grounded filter, nearby structure, or ground rod.
  - d. The Contractor must provide a stainless-steel spool piece matching the main recirculation header pipe size installed between flanges downstream of the recirculation pump(s) and upstream of the filters to facilitate installation of the "T" signal tag per manufacturer requirements. Coating must be 3M Scotchkote 134 fusion bonded epoxy, or approved equivalent on the complete interior of fitting.
  - e. The maximum cable run length from the control cabinet (typically wall mounted) to the "T" signal tag installed on the pool recirculation pipe must be 33 feet. Installation locations must be coordinated to meet this parameter.

9. The Clear-Flow system unit must be rated for -40° F + 140° F ambient operation. The unit must have no ventilation requirements and be able to be used indoors and outdoors.
10. After identifying the proper installation location for the “T” tag, the Contractor must prepare the point for strong electrical contact with the tag. The Contractor must remove any epoxy or enamel coating which may inhibit a strong connection. The Contractor to make output connections per wiring schematic. Connect “T” and “A” connections into the labeled terminals inside the enclosure.
11. The Contractor must confirm Clear-Flow system is functioning properly and operating under the following conditions. After powering on the unit, consult the LCD screen to determine the frequency and amperage output.
  - a. The optimal frequency range is between 100-350 kHz.
  - b. Optimal amperage is between 1 and 5 amps.
  - c. If frequency and amperage are outside of these ranges, the Contractor must adjust capacitor switches on the upper right side inside the enclosure.
  - d. If current amperage is not achievable under 5 amps after making capacitor adjustments, the Contractor must disconnect “A” tag from inside the terminal block and repeat adjustment of capacitors.
  - e. If these steps do not result in an optimal sine wave within the recommended frequency and amperage, the Contractor must consult a Clear-Flow Representative.
  - f. As an additional means of signal verification, an oscilloscope can be used. By touching the oscilloscope probe onto the pipe near where the “T” tag is connected, signal strength and frequency can be measured. A clean, declining sine wave with minimal harmonics should be observed.
12. The Contractor must cut excess signal cable, but not to less than 10 feet (3 meters) in length. The Contractor must not coil power cord or signal cables; doing so will interfere with signal operation.
13. The Clear-Flow system must be powered on/off via a switch on the enclosure.
14. Replacement fuses must be UL-listed.
15. The complete installation must be by the manufacturer’s installation instructions and certified on-site for proper operation by the manufacturer’s representative for each system installation.
16. The Clear-Flow system requires that the electrical supply be properly grounded. The Contractor must follow Institute of Electrical and Electronics Engineers (IEEE) standards ensuring a ground resistance of 5 ohms or less.

#### **2.04 FLOW METERS**

- A. Impact flow meter must be provided as indicated on the drawings. Impact flow meter must be a pilot, impact ball, variable area type with one piece, impact resistant machined acrylic plastic body. GPM scale must be permanently etched or imprinted on the meter. Flow rate indicator must be of stainless-steel material. The scale range must be appropriate for a specific flow rate. Pipe size to accommodate backwash rate. The backwash piping flow meter must be BLUE-WHITE series F-300 or approved equal.

### **PART 3 - EXECUTION**

#### **3.01 EXISTING CONDITIONS, INSPECTION AND PREPARATION**

- A. Carefully examine the contract documents for requirements that affect the work of this section. Prior to starting work, notify the Consultant of defects requiring correction. Do not start work until conditions are satisfactory.
- B. Verify that work by others, related to this section, has been completed. This includes earthwork, concrete work, and mechanical, electrical, and plumbing connections.
- C. Protect materials and work completed by others from damage while completing the work in this section.

#### **3.02 FIELD MEASUREMENTS**

- A. Verify benchmark and pool location prior to layout.
- B. If field measurements differ from the construction drawing dimensions, notification must be given to the Consultant prior to proceeding with work.

#### **3.03 PIPING INSTALLATION**

- A. General
  - 1. Provide and erect, according to the best practices of the trade, piping shown on the drawings and required for the complete installation of these systems. The piping shown on the drawings must be considered as diagrammatic in indicating the general run and connections and may or may not in parts be shown in its true position. The piping may have to be offset, lowered, or raised as required or as directed at the site. This does not relieve responsibility for the proper erection of the systems or piping in every respect suitable for the work intended as described in the specifications and approved by the Consultant. In the erection of piping, it must be properly supported, and proper provisions must be made for expansion, contraction and anchoring of piping. Piping must be cut accurately for fabrication to measurements established at the construction site. Pipe must be worked into place without springing and/or forcing, properly clearing windows, doors, and other openings and equipment. Cutting or other weakening of the building structure to facilitate installation will not be permitted. Pipes must have burrs and/or cutting slag removed by reaming or other cleaning methods in strict accordance with the manufacturer's instructions. Changes in direction must be made with fittings. Open ends of pipes and equipment must be properly capped or plugged to keep dirt and other foreign materials out of the systems. Plugs of rags, wool, cotton waste or similar materials will not be used in plugging. Piping must be arranged so as not to interfere with removal and maintenance of equipment, filters, or devices, and so as not to block access to manholes, access openings, etc. Flanges or unions applicable for the type of piping specified must be provided in the piping at connections to items of equipment. Piping must be installed to ensure noiseless circulation. Valves and specialties must be so placed to permit easy operation and access.
- B. Pipe Hangers and Supports
  - 1. Pipes must be adequately supported by pipe hangers and supports as specified.
  - 2. Horizontal PVC Schedule 80 piping must be supported in accordance with the manufacturer's recommendations for fluid temperature not exceeding 120-degree F and as listed below:

Nominal Pipe Size	Hanger Support Spacing	Minimum Rod Size for Single Rod Hanger
1-1/4" and less	5'-0"	3/8"
1-1/2" to 3"	6'-0"	1/2"
4" to 6"	8'-0"	5/8"

8" to 12"	10'-0"	7/8"
Greater than 12"	12'-0"	1"

3. Round rods supporting the pipe hangers must be of the following dimensions:

Nominal Pipe Size	Rod Diameter
1/2" to 2" pipe	-3/8" rod
2-1/2" to 3" pipe	-1/2" rod
4" to 5" pipe	-5/8" rod
6" pipe	-3/4" rod

4. Hanger rods must be galvanized steel. Provide for controlling level and slope by turn buckles or other approved means of adjustment and incorporate lock nuts.
5. Provide means of preventing dissimilar metal contact such as plastic-coated hangers, copper colored epoxy paint, or non-adhesive isolation tape.
6. Provide hangers to provide a minimum of 1-inch space between finished covering and adjacent work.
7. Place a hanger within 12 inches of each horizontal elbow.
8. Support vertical piping independently of connected horizontal piping. Support vertical pipes at every floor. Wherever possible, locate riser clamps directly below pipe couplings or shear lugs.
9. Where several pipes can be installed in parallel and at the same elevation, provide trapeze hangers as specified. Trapeze hangers must be spaced according to the smallest pipe size or provide intermediate supports according to the support spacing schedules. Provide heavier members as required for the load supported for the entire span distance. Hanger rods must be as specified above and properly sized for the load supported, but not less than 5/8 inches diameter.
10. Piping must be rigidly supported from the building structure by means of hanger assemblies properly selected and sized for the application in accordance with the manufacturer's recommendations and specifications. Do not support piping from other pipes, ductwork or other equipment that is not building structure. Do not modify the building structure for hanger installation.
11. Attachment of piping hangers to the building structure must be provided in a manner approved by the Consultant. Provide concrete inserts installed by others in the building construction at the time the concrete is poured, and hangers must be attached to these inserts.
12. The use of pipe hooks, chains, or perforated iron for pipe hanger supports will not be permitted.
13. A design for piping in a service tunnel, if required, supported by a structure must be submitted for approval. The structure must be non-corrodible and must be of a size and configuration to rigidly support the piping as shown in the plans at a minimum spacing as shown below.
- C. Concrete Inserts
1. Provide inserts for suspending hangers from reinforced concrete slabs and sides of reinforced concrete beams.
  2. Where concrete slabs form finished ceilings, inserts must be flush with the slab surface.
  3. Provide hook rods to concrete reinforcement section for inserts carrying pipe over 4 inches.
- D. Flushing, Draining and Cleaning Pipe Systems

1. Flush out water systems with water before placing them in operation. Other systems must be cleaned by using compressed air or nitrogen. After systems are in operation and during the test period, strainer screens must be removed and thoroughly cleaned.

E. Testing

1. Piping installation and pressure testing must be performed by the Contractor and reviewed by the Owner or a designated representative of the Owner. A minimum one (1) week notice must be provided prior to review. Results must be submitted to the Consultant. Pictures with time stamps for each section of piping must be included with testing report(s) and be submitted within one (1) week of the pressure test(s).
2. Newly installed pool piping must be capped and hydraulically pressure tested with water to a pressure of not less than 50 PSI for a period of no less than two (2) hours. Pressure testing must be conducted in accordance with ASTM D2774. The temperature of the water used for the test must be between 40°F and 90°F.
3. Pneumatic testing (air) of any pool piping will not be accepted.

**3.04 EQUIPMENT AND SYSTEMS INSTALLATION**

- A. Provide and assemble equipment, special parts and accessories as shown on pool drawings, specifications, and shop drawings of the equipment suppliers.
- B. Provide anchors and inserts properly imbedded including fittings, inserts and structure sleeves and required anchorage as shown on the plans and as indicated in this section of the specifications. Equipment must be set true and plumb, using factory jigs where available.
- C. Provide templates for equipment anchors. Provide anchor bolts of the size and spacing as required by the equipment manufacturer. Anchor bolts must be stainless-steel Type 316L and of a length capable of adequate anchorage.
- D. Provide equipment and systems in accordance with manufacturer's directions. Equipment must be assembled and in place for final observation.
- E. Items necessary to complete this section are shown on the plans or described in the specifications including items that may be purchased by the Owner. Items are detailed and specified as a guide for dimensional purposes. Make provisions accordingly and submit shop drawings and submittals based on that data.

**3.05 START-UP AND INSTRUCTION**

- A. Supply the services of an experienced swimming pool operator/instructor for a period of not less than one day (total 8 hours) after the pool equipment has been placed in operation. During this period, the Owner's representatives who will be operating the pool(s) must be thoroughly instructed on the operation of the new equipment. Deliver two (2) complete sets of operating and maintenance instructions for the swimming pool equipment. Prior to leaving the job, obtain written certification from the designated Owner's representative acknowledging that the instruction period has been completed and necessary operating information provided.

**END OF SECTION**



**CITY OF KENORA  
REQUEST FOR TENDER**

**ITT# 733-001-22**

**APPENDIX 4  
DRAWINGS**

# CITY OF KENORA MONCRIEF SPORTS CENTRE

STANTEC PROJECT NO. 115425040

DATE OF ISSUE: 2026.06.15

ISSUED FOR: CONSTRUCTION

## PROJECT TEAM:

**PRIME CONSULTANT:**  
**STANTEC CONSULTING LTD**  
500-311 Portage Avenue  
Winnipeg, Manitoba R3B 2B9  
tel:(204) 489-5900

**ELECTRICAL CONSULTANT:**  
**STANTEC CONSULTING LTD**  
500-311 Portage Avenue  
Winnipeg, Manitoba R3B 2B9  
tel:(204) 489-5900

**SPECIAL CONSTRUCTION CONSULTANT:**  
**COUNSILMAN-HUNSAKER**  
12265 W Bayaud Ave, Suite 110  
Lakewood, Colorado 80228

## DRAWING LIST:

- GENERAL  
G-001 COVER SHEET
- ELECTRICAL  
E-101 COMPETITION POOL MECHANICAL ROOM - ELECTRICAL PLAN  
E-102 LEISURE POOL MECHANICAL ROOM - ELECTRICAL PLAN  
E-500 ELECTRICAL SCHEDULES AND DIAGRAMS
- SPECIAL CONSTRUCTION  
A00.0 POOL REFERENCE PLAN  
A00.1 LEISURE POOL MECHANICAL ROOM DEMOLITION PLAN  
A00.2 COMPETITION POOL MECHANICAL ROOM DEMOLITION PLAN  
A01.0 POOL MECHANICAL NOTES & SCHEDULES  
A01.1 LEISURE POOL MECHANICAL ROOM RENOVATION PLAN  
A01.2 COMPETITION POOL MECHANICAL ROOM RENOVATION PLAN  
A01.3 POOL MECHANICAL RENOVATION DETAILS  
A01.4 POOL MECHANICAL RENOVATION DETAILS  
A02.0 POOL SYSTEMS SCHEMATIC  
A02.1 HOT TUB & POOL SYSTEMS SCHEMATIC

**REFER TO SPECIFICATION SECTION 01 11 00, ARTICLE 1.01, PARAGRAPH .1 FOR DESCRIPTION OF WORK INCLUDED IN THIS CONTRACT AND FOR EXCLUSIONS PERTAINING TO THE POOL FILTRATION SYSTEM.**

Revision	By	Appd	YYYY.MM.DD

Revision By Appd YYYY.MM.DD

ISSUED FOR CONSTRUCTION ED AH 2026.06.15

ISSUED FOR PPS REVIEW ED AH 2026.06.09

Issued By Appd YYYY.MM.DD

File Name: 115425040\_G001 ED ED AH 2026.06.24

Dwn. Dgn. Chkd. YYYY.MM.DD

Permit/Seal



Client/Project Logo

Client/Project  
CITY OF KENORA

MONCRIEF SPORTS CENTRE

18 MIKE RICHARD'S WAY, KENORA, ON

Title  
COVER SHEET

Project No.  
115425040

Scale  
N/A

Revision Sheet

Drawing No.

1 of 14

**G-001**

**Copyright Reserved**

The Contractor shall verify and be responsible for all dimensions. DO NOT scale the drawing.  
- any errors or omissions shall be reported to Stantec without delay.  
The Copyrights to all designs and drawings are the property of Stantec. Reproduction or use for any purpose other than that authorized by Stantec is forbidden.

**Consultant**

**Notes**

**GENERAL NOTES:**

- WHERE RECEPTACLES ARE SERVING PUMPS WITH NO STRUCTURE, ALL RECEPTACLES SHALL BE MOUNTED ON GALVANIZED STRUT CHANNEL INDEPENDENTLY SUPPORTED FROM CEILING. ALL HARDWARE SHALL BE STAINLESS STEEL.
- ALL CABLING IS TO BE SUPPORTED INDEPENDENTLY OF PIPING SYSTEMS.
- ALL CORDS AND CABLES SHALL ENTER JUNCTION BOXES UTILIZING PVC STRAIN RELIEF CONNECTORS AND SEALING RINGS.
- CONDUIT IS NOT TO BE UTILIZED AS A SUPPORT.
- ALL FLEXIBLE CORDS/CABLES TO BE TYWRAPPED, OR CLIPPED NO MORE THAN 150MM FROM EACH POINT OF CONNECTION AND NOT EXCEEDING 600MM THEREAFTER.
- PROVIDE 4 INCH ALUMINUM CABLE TRAY ON WALL AND SUPPORT ALL CABLES AND CONDUIT IN TRAY.
- VERIFY PANEL N SPARE CAPACITY BY DATA LOGGING PANEL N FOR A MINIMUM OF 48 HOURS. SUBMIT DATA LOG REPORT FOR OWNER'S REVIEW. INCLUDE A COPY OF THE DATA LOG REPORT IN THE O&M MANUAL.
- UPGRADE EXISTING WIRING TO WIRE SIZES INDICATED ON THE EQUIPMENT SCHEDULE.

**KEYNOTES:**

- EXISTING ACID PH BUFFER SYSTEM TO BE REPLACED WITH NEW BY DIVISION 13. PROVIDE TWO (2) NEW 20A SWITCHED RECEPTACLES, LEVITON 5335 OR APPROVED EQUIVALENT, C/W WEATHERPROOF COVER.
- EXISTING CHLORINATION SANITIZATION SYSTEM TO BE REPLACED WITH NEW BY DIVISION 13. PROVIDE TWO (2) NEW 20A SWITCHED RECEPTACLES, LEVITON 5335 OR APPROVED EQUIVALENT, C/W WEATHERPROOF COVER.
- EXISTING FLOCCULATION SYSTEM TO BE REPLACED WITH NEW BY DIVISION 13. PROVIDE NEW 20A GFCI SWITCHED RECEPTACLE, LEVITON 5335 OR APPROVED EQUIVALENT, C/W WEATHERPROOF COVER.

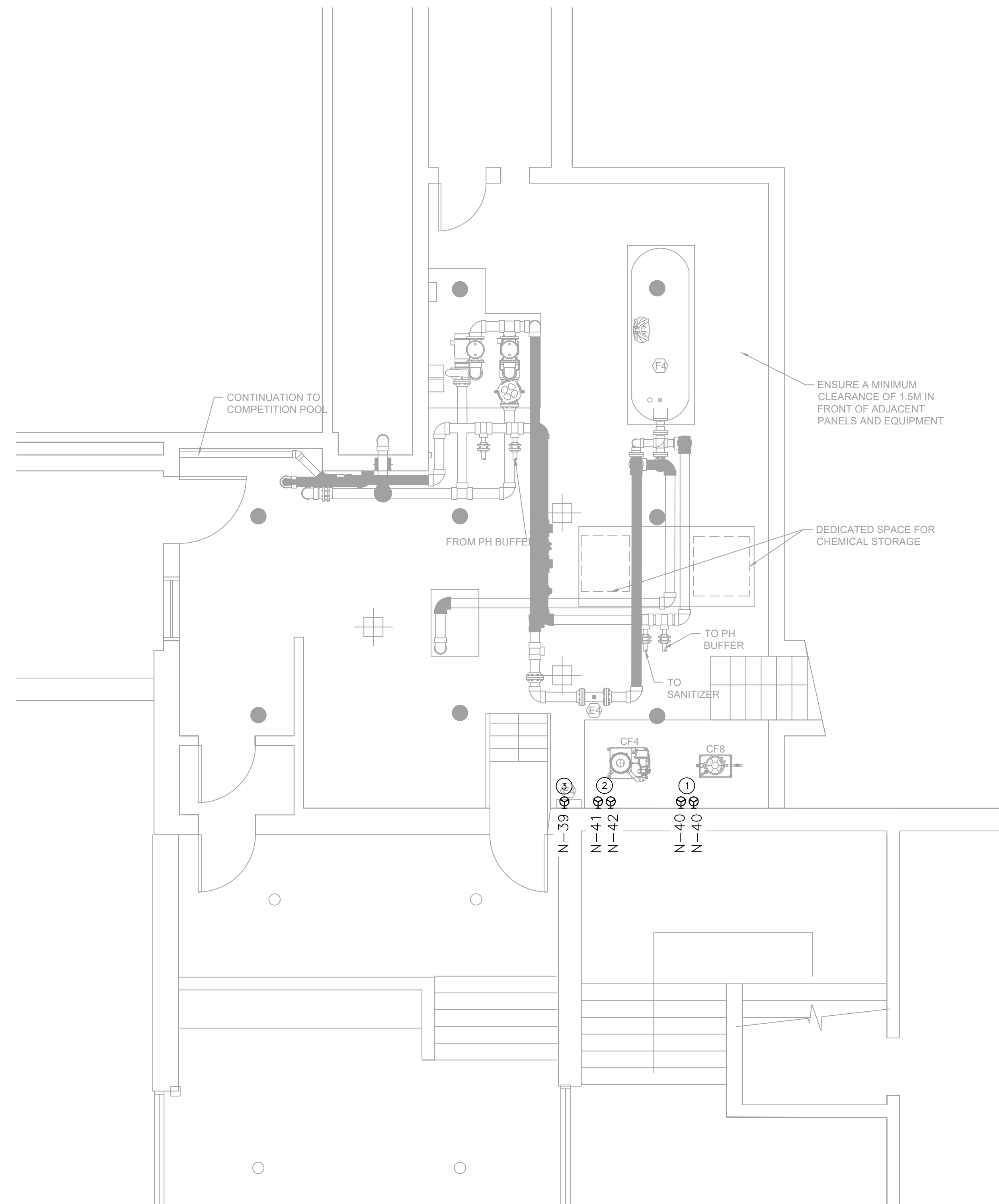

1 COMPETITION POOL MECHANICAL ROOM - ELECTRICAL PLAN  
E-101 1/4" = 1'-0"

POWER PLAN SYMBOLS	
	SPECIAL RECEPTACLE (TYPE AS INDICATED)
	PANELBOARD

**Revision**

By	Appd	YYYY.MM.DD

ISSUED FOR CONSTRUCTION	ED	AH	2026.06.15
ISSUED FOR PPS REVIEW	ED	AH	2026.06.09

**Issued**

File Name: 115425040_E101	ED	ED	AH	2026.05.24
	Dwn.	Dgdn.	Chkd.	YYYY.MM.DD

**Permit/Seal**



**Client/Project Logo**

Client/Project  
CITY OF KENORA

MONCRIEF SPORTS CENTRE

18 MIKE RICHARD'S WAY, KENORA, ON

Title  
COMPETITION POOL MECHANICAL ROOM - ELECTRICAL PLAN

Project No.  
115425040

Scale  
1/4" = 1'-0"

Revision Sheet

Drawing No.

2 of 14

**E-101**





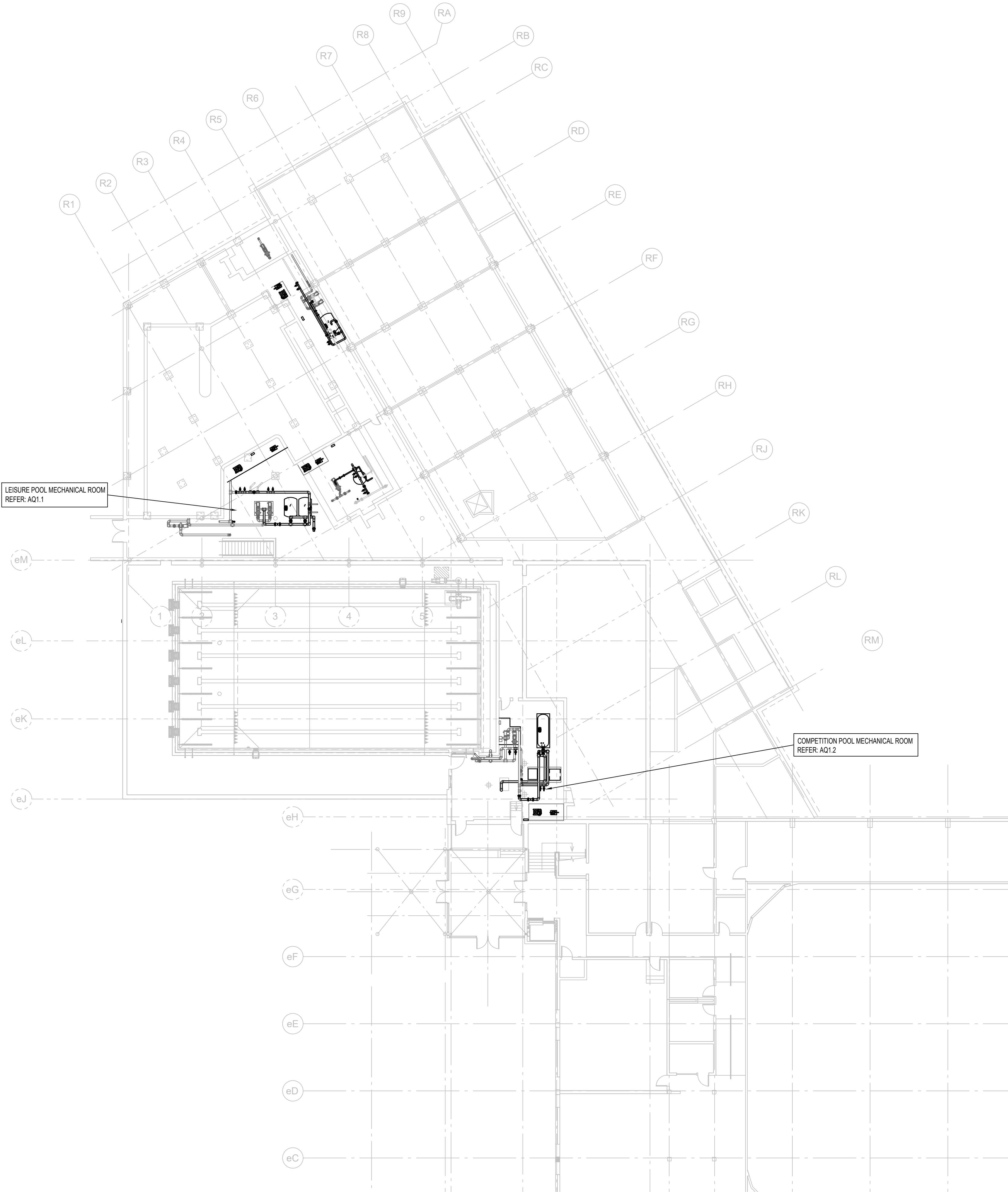

DESIGN DATA*					
	UNITS	LEISURE POOL	TOT POOL	HOT TUB	COMPETITION POOL
LENGTH	FT.	62'-0"	16'-0"	13'-0"	82'-0"
WIDTH	FT.	58'-0"	18'-0"	9'-0"	44'-0"
WATER SURFACE AREA	SQ. FT.	2,220	298	120	3,608
PERIMETER	FT.	216'-0"	68'-0"	44'-0"	252'-0"
VOLUME	GALLONS	50,000	6,300	2,400	155,000
RECIRCULATION SYSTEM					
POOL TURNOVER RATE	HOURS	2.22	1.02	0.23	4.53
RECIRCULATION RATE	GPM	375	103	173	570

\*NOTE: VALUES WERE TAKEN FROM A POOL AUDIT REPORT DATED JUNE 19, 2024 - AQUATIC DESIGN & ENGINEERING.

- ### GENERAL POOL NOTES
- ALL PROPRIETARY NAMES MENTIONED ARE TO DESIGNATE PERFORMANCE STANDARDS. EQUIVALENT PRODUCTS MUST BE SUBMITTED FOR APPROVAL.
  - REFER TO ELECTRICAL FOR ELECTRICAL REQUIREMENTS IN POOL MECHANICAL ROOMS.
  - ELECTRICAL INSPECTOR MUST APPROVE INSTALLATION OF GROUNDING AND BONDING.
  - CONTRACTOR TO PROVIDE CHEMICAL QUANTITIES PER CONTRACTOR SUPPLIED POOL CHEMICAL SCHEDULE AFTER INITIAL WATER BALANCE IS REACHED PRIOR TO OWNER TURNOVER.

- ### GENERAL POOL DEMOLITION AND RENOVATION NOTES
- COORDINATE ALL DEMOLITION PLANS AND WORK WITH ARCHITECT AND CONSTRUCTION DOCUMENTS PRIOR TO THE START OF DEMOLITION.
  - REVIEW RECORD DOCUMENTS OF EXISTING CONSTRUCTION PROVIDED BY THE OWNER. NEITHER THE OWNER NOR ENGINEER MAKES ANY GUARANTEE THAT THE EXISTING CONDITIONS REFLECT THOSE INDICATED IN THE RECORD DOCUMENTS. CONTRACTOR TO PROVIDE NOTIFICATION OF ANY DISCREPANCIES BETWEEN EXISTING CONDITIONS AND THE CONTRACT DOCUMENTS BEFORE PROCEEDING WITH DEMOLITION.
  - CONTRACTOR TO SURVEY EXISTING CONDITIONS AND CORRELATE WITH REQUIREMENTS INDICATED IN THE CONTRACT DOCUMENTS TO DETERMINE THE EXTENT OF DEMOLITION REQUIRED. CONTRACTOR TO RECORD EXISTING CONDITIONS WITH DETAILED PRECONSTRUCTION PHOTOGRAPHS.
  - UNLESS OTHERWISE INDICATED, DEMOLITION WASTE BECOMES PROPERTY OF THE CONTRACTOR.
  - EXCEPT FOR ITEMS OR MATERIALS INDICATED TO BE RECYCLED, REUSED, SALVAGED, REINSTALLED, OR OTHERWISE INDICATED TO REMAIN OWNER'S PROPERTY, REMOVE DEMOLISHED MATERIALS FROM PROJECT SITE AND LEGALLY DISPOSE OF THEM. OWNER HAS THE FIRST RIGHT OF REFUSAL ON ALL DEMOLITION MATERIALS.
  - IF HAZARDOUS MATERIALS ARE ENCOUNTERED, DO NOT DISTURB. IMMEDIATELY NOTIFY THE OWNER AND ENGINEER.
  - INDICATE RECEIPT AND ACCEPTANCE OF ANY HAZARDOUS WASTES BY A LANDFILL FACILITY LICENSED TO ACCEPT SUCH HAZARDOUS WASTES.
  - MAINTAIN EXISTING UTILITIES TO REMAIN IN SERVICE AND PROTECT THEM AGAINST DAMAGE DURING DEMOLITION OPERATIONS. REFER TO OTHER TRADES FOR COORDINATION.
  - ELECTRICIAN MUST VERIFY EXISTING BOND GRID. ALL NEW EMBEDS AND MECHANICAL EQUIPMENT MUST BE BONDED PER CANADIAN ELECTRICAL CODE.
  - CONTRACTOR TO DRAIN AND FILL TILED POOLS AND HOT TUB AT A RATE NOT TO EXCEED 1" OF POOL DEPTH PER HOUR AND AT A WATER TEMPERATURE WITHIN 10 DEGREES FAHRENHEIT OF AMBIENT TO CONTROL MOISTURE AND THERMAL SHOCK TO THE TILE.
  - PROTECT ALL EXISTING POOL FINISHES, GUTTERS, MAIN DRAINS, AND ANY OTHER POOL RELATED APPURTENANCES DURING CONSTRUCTION.
  - THE CONTRACTOR MUST BE RESPONSIBLE FOR CONTINUOUSLY MONITORING GROUNDWATER LEVELS ON THE SITE DURING ANY AND ALL PERIODS WHEN THE SWIMMING POOL IS NOT FULL OF WATER. PROTECTION OF THE EXISTING POOL STRUCTURE FROM DAMAGE DUE TO HYDROSTATIC PRESSURE IS THE SOLE RESPONSIBILITY OF THE CONTRACTOR.
  - CLEAN ADJACENT STRUCTURES AND IMPROVEMENTS OF DUST, DIRT, AND DEBRIS FOLLOWING DEMOLITION OPERATIONS. CONTRACTOR TO RETURN ADJACENT AREAS TO CONDITION EXISTING BEFORE THE START OF DEMOLITION OPERATIONS.

DRAWING INDEX	
SHEET	DESCRIPTION
AQ0.0	POOL REFERENCE PLAN
AQ0.1	LEISURE POOL MECHANICAL ROOM DEMOLITION PLAN
AQ0.2	COMPETITION POOL MECHANICAL ROOM DEMOLITION PLAN
AQ1.0	POOL MECHANICAL NOTES & SCHEDULES
AQ1.1	LEISURE POOL MECHANICAL ROOM RENOVATION PLAN
AQ1.2	COMPETITION POOL MECHANICAL ROOM RENOVATION PLAN
AQ1.3	POOL MECHANICAL RENOVATION DETAILS
AQ1.4	POOL MECHANICAL RENOVATION DETAILS
AQ2.0	POOL SYSTEMS SCHEMATICS
AQ2.1	HOT TUB & POOL SYSTEMS SCHEMATICS

CONTRACTOR SUPPLIED POOL CHEMICALS	
DESCRIPTION	AMOUNT
CALCIUM HYPOCHLORITE	FULL FEEDER(S) + 300 LBS
SODIUM BISULFATE	FULL FEEDER(S) + 100 LBS

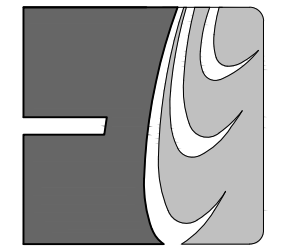

Professional Seal



Drawn: KAS  
Checked: CJR  
Checked: CCH

No.	Description	Date
01	100% CD	06/15/2026

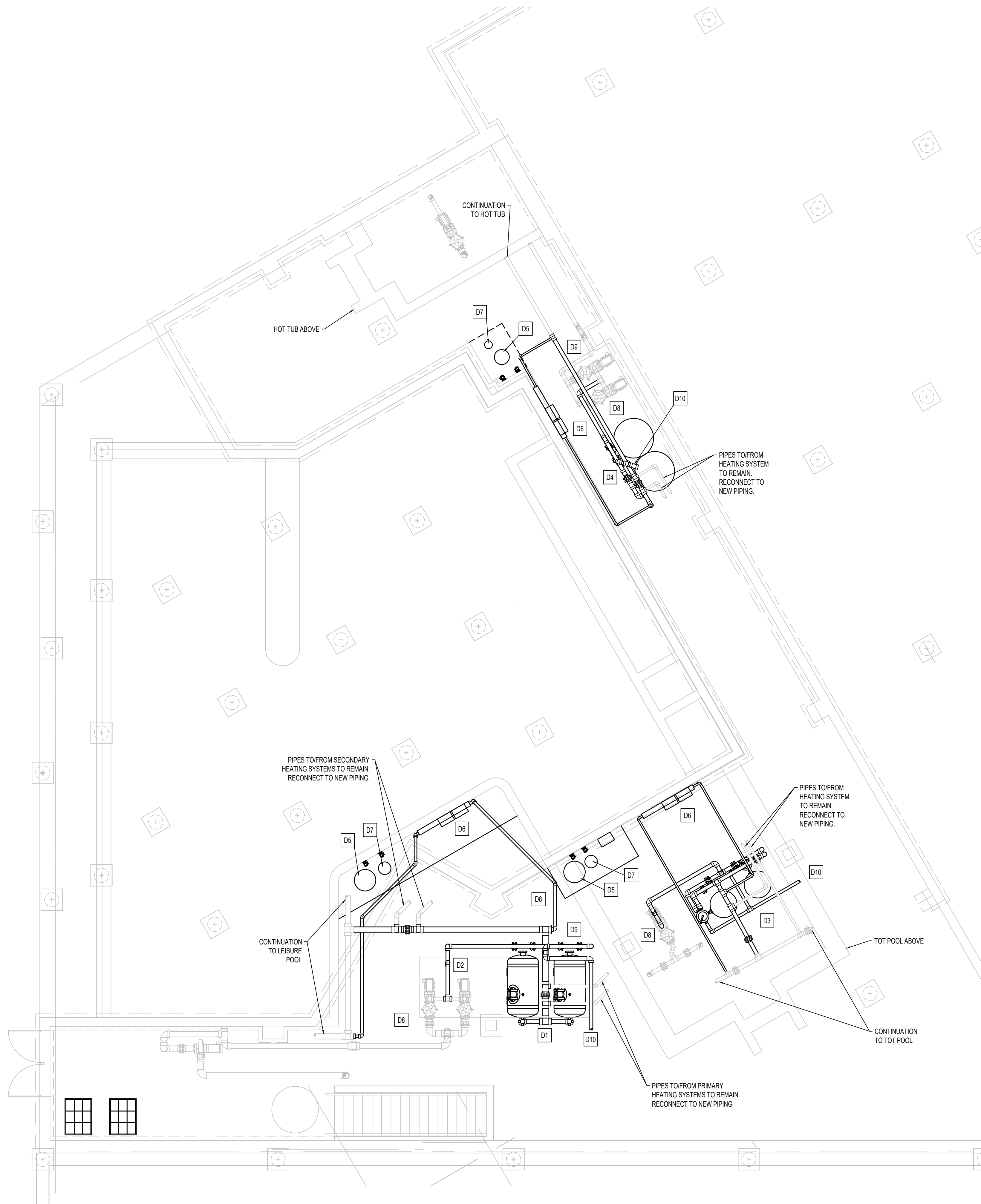

POOL DEMOLITION KEYNOTES	
COORDINATE ALL DEMOLITION PLANS WITH ARCHITECT AND CONSTRUCTION DOCUMENTS PRIOR TO DEMOLITION	
D1	REMOVE AND PROPERLY DISPOSE OF EXISTING LEISURE POOL SAND FILTERS AND ASSOCIATED FACE PIPING, VALVES, FITTINGS AND SUPPORTS.
D2	REMOVE AND PROPERLY DISPOSE OF 4" LEISURE POOL PRESSURE PIPING, VALVES, AND FITTINGS LOCATED BETWEEN THE EXISTING RECIRCULATION PUMPS AND SAND FILTERS.
D3	REMOVE AND PROPERLY DISPOSE OF EXISTING TOT POOL SAND FILTER AND ASSOCIATED FACE PIPING, VALVES, FITTINGS AND SUPPORTS.
D4	REMOVE AND PROPERLY DISPOSE OF EXISTING HOT TUB SAND FILTERS AND ASSOCIATED FACE PIPING, VALVES, FITTINGS AND SUPPORTS.
D5	REMOVE AND PROPERLY DISPOSE OF EXISTING MURIATIC ACID SYSTEMS FOR ALL BODIES OF WATER INCLUDING BUT NOT LIMITED TO BULK STORAGE TANKS, CHEMICAL FEED PUMPS, CHEMICAL TUBING/FITTINGS, AND EXCESS CHEMICALS.
D6	REMOVE AND PROPERLY DISPOSE OF EXISTING LECTRANATOR CHLORINE GENERATION SYSTEMS FOR ALL BODIES OF WATER INCLUDING BUT NOT LIMITED TO THE PHYSICAL SYSTEMS, CONTROLLERS, CELLS, AND ASSOCIATED PIPING, FITTINGS AND VALVES.
D7	REMOVE AND PROPERLY DISPOSE OF EXISTING LIQUID FLOCCULANT SYSTEMS FOR ALL BODIES OF WATER INCLUDING BUT NOT LIMITED TO BULK STORAGE TANKS, CHEMICAL FEED PUMPS, CHEMICAL TUBING/FITTINGS, AND EXCESS CHEMICALS.
D8	PROTECT AND REUSE ALL EXISTING POOL EQUIPMENT NOT SPECIFICALLY IDENTIFIED FOR DEMOLITION AND REPLACEMENT INCLUDING BUT NOT LIMITED TO THE CHEMICAL CONTROLLER, PUMPS, MOTORS, GAUGES, FLOW METERS, MOTOR STARTERS, MOTOR DISCONNECTS, WATER LEVEL CONTROLLER SYSTEMS, HEATING SYSTEMS AND ASSOCIATED CONTROLS/SENSORS, AND ALL ASSOCIATED PIPING, FITTINGS, AND SUPPORTS.
D9	REMOVE AND PROPERLY DISPOSE OF ALL EXISTING PIPING AND PIPING SUPPORTS IDENTIFIED WITH LARGER LINEWEIGHT (BOLD). ALL GREYSKALE PIPING AND PIPING SUPPORTS MUST REMAIN.
D10	REMOVE AND PROPERLY DISPOSE OF APPROXIMATELY 3M OF EXISTING BACKWASH PIPING DOWNSTREAM OF FILTER SYSTEMS. STRATEGICALLY SAWCUT BACKWASH PIPES AT LOCATIONS CONDUCTIVE FOR RECONNECTION TO NEW FILTER SYSTEM BACKWASH PIPING. EXISTING DOWNSTREAM BACKWASH PIPING, FALLOUT, AND CONTINUATION TO REMAIN AND BE REUSED.

1 LEISURE POOL MECHANICAL ROOM DEMOLITION PLAN  
3/16" = 1'-0"



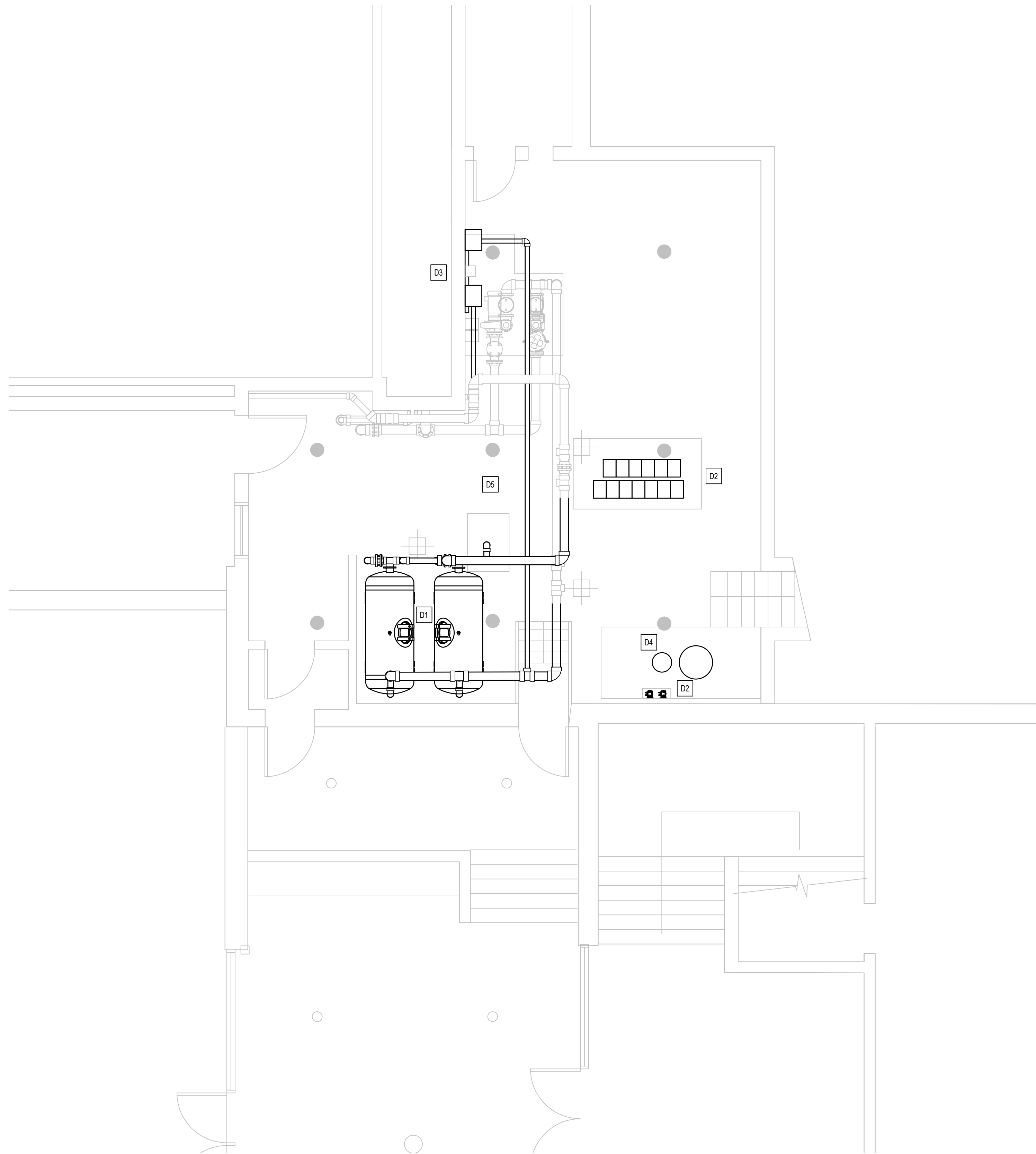

POOL DEMOLITION KEYNOTES	
COORDINATE ALL DEMOLITION PLANS WITH ARCHITECT AND CONSTRUCTION DOCUMENTS PRIOR TO DEMOLITION	
D1	REMOVE AND PROPERLY DISPOSE OF EXISTING COMPETITION POOL SAND FILTERS AND ASSOCIATED FACE PIPING, VALVES, FITTINGS AND SUPPORTS.
D2	REMOVE AND PROPERLY DISPOSE OF EXISTING MURIATIC ACID SYSTEM INCLUDING BUT NOT LIMITED TO BULK STORAGE TANK, CHEMICAL FEED PUMP, CHEMICAL TUBING/FITTINGS, AND EXCESS CHEMICALS.
D3	REMOVE AND PROPERLY DISPOSE OF EXISTING ELECTROLYTIC CHLORINE GENERATION SYSTEM INCLUDING BUT NOT LIMITED TO THE PHYSICAL SYSTEMS, CONTROLLERS, CELLS, AND ASSOCIATED PIPING, FITTINGS, AND VALVES.
D4	REMOVE AND PROPERLY DISPOSE OF EXISTING LIQUID FLOCCULANT SYSTEM INCLUDING BUT NOT LIMITED TO THE BULK STORAGE TANK, CHEMICAL FEED PUMP, CHEMICAL TUBING/FITTINGS, AND EXCESS CHEMICALS.
D5	PROTECT AND REUSE ALL EXISTING POOL EQUIPMENT NOT SPECIFICALLY IDENTIFIED FOR DEMOLITION AND REPLACEMENT INCLUDING BUT NOT LIMITED TO THE CHEMICAL CONTROLLER, PUMPS, MOTORS, GAUGES, FLOW METERS, MOTOR STARTERS, MOTOR DISCONNECTS, WATER LEVEL CONTROLLER SYSTEM, HEATING SYSTEM AND ASSOCIATED CONTROLS/SENSORS, AND ALL ASSOCIATED PIPING, FITTINGS, AND SUPPORTS.
D6	REMOVE AND PROPERLY DISPOSE OF ALL EXISTING PIPING AND PIPING SUPPORTS IDENTIFIED WITH LARGER LINEWEIGHT (BOLD). ALL GREYSKALE PIPING AND PIPING SUPPORTS MUST REMAIN.

1 COMPETITION POOL MECHANICAL ROOM DEMOLITON PLAN  
1/4" = 1'-0"

PROJECT:  
MONCREEF SPORTS CENTRE  
POOL MECHANICAL RENOVATION  
KENORA, ON

Professional Seal



Drawn: KAS  
Checked: CJR  
Checked: CCH

No.	Description	Date
01	100% CD	06/15/2026

COMPETITION POOL  
MECHANICAL ROOM  
DEMOLITION PLAN

AQ0.2

CHEMICAL FEED SCHEDULE						
ID	DESCRIPTION	MANUFACTURER	MODEL	HP	FLOW	
CF1	LEISURE POOL CHLORINATION BOOSTER PUMP REFER: 1/AQ1.3	ACCUTAB	1030	1	67 LBS/DAY	
CF2	TOT POOL CHLORINATION BOOSTER PUMP REFER: 1/AQ1.3	ACCUTAB	1030	1	67 LBS/DAY	
CF3	HOT TUB CHLORINATION BOOSTER PUMP REFER: 1/AQ1.3	ACCUTAB	1030	1	67 LBS/DAY	
CF4	COMPETITION POOL CHLORINATION BOOSTER PUMP REFER: 1/AQ1.3	ACCUTAB	1030	1	67 LBS/DAY	
CF5	LEISURE POOL ACID FEED PUMP REFER: 2/AQ1.3	ACID-RITE	450	1	12 LBS/HR	
CF6	TOT POOL ACID FEED PUMP REFER: 2/AQ1.3	ACID-RITE	450	1	12 LBS/HR	
CF7	HOT TUB ACID FEED PUMP REFER: 2/AQ1.3	ACID-RITE	450	1	12 LBS/HR	
CF8	COMPETITION POOL ACID FEED PUMP REFER: 2/AQ1.3	ACID-RITE	450	1	12 LBS/HR	

NOTE:  
 1. THE MANUFACTURER INDICATED IS BASIS OF DESIGN. ALTERNATE MANUFACTURER: PULSAR OR APPROVED EQUAL.  
 2. PROVIDE WITH 120 VOLT, SINGLE PHASE.  
 3. INTERLOCK WITH POOL RECIRCULATION PUMP.

GENERAL POOL MECHANICAL ROOM NOTES
<ol style="list-style-type: none"> <li>VENTILATION OF POOL MECHANICAL ROOM AND CHEMICAL STORAGE AREAS PER LOCAL, PROVINCIAL AND INTERNATIONAL MECHANICAL CODE MINIMUM. REFER TO MECHANICAL.</li> <li>REFER TO MECHANICAL FOR HVAC SYSTEMS DESIGN.</li> </ol> <p><u>PIPING AND VALVING</u></p> <ol style="list-style-type: none"> <li>MINIMUM 7'-0" CLEARANCE BENEATH ALL OVERHEAD PIPING.</li> <li>PROVIDE AND SUPPORT OVERHEAD AND VERTICAL PIPING PER SPECIFICATION REQUIREMENTS.</li> <li>ALL FLOW METERS MUST BE SIZED TO MATCH THE PIPE ON WHICH IT IS INSTALLED. PROVIDE PRESSURE GAUGES ON INFLUENT AND EFFLUENT SIDE OF EACH FILTRATION SYSTEM AND A FULL LINE SIZE FLOW METER ON FILTER RETURN.</li> <li>HYDROSTATICALLY TEST ALL PIPING AT 50 PSI FOR TWO HOURS AND MAINTAIN A PRESSURE OF 20 PSI IN ALL PIPING THROUGHOUT CONSTRUCTION. SECURE ALL FIXTURES PER SPECIFICATION REQUIREMENTS BEFORE HYDROSTATIC TEST.</li> <li>REFER TO DETAILS 1-6 ON DRAWING AQ1.4 FOR INSTALLATION OF PIPE SUPPORTS.</li> <li>ALL VALVE HARDWARE MUST BE 316L STAINLESS STEEL AND MEET ANSI HARDWARE INSTALLATION GUIDELINES. REFER: 7/AQ1.3</li> <li>ALL BALANCING VALVES AND BUTTERFLY VALVES MUST BE PROVIDED WITH POSITION INDICATORS AND MAXIMUM ADJUSTABLE STOPS (MEMORY STOPS).</li> <li>ALL VALVES MUST BE INSTALLED SO THAT THE VALVE REMAINS IN SERVICE WHEN THE EQUIPMENT OR PIPING ON THE EQUIPMENT SIDE OF THE VALVE IS REMOVED.</li> <li>PROVIDE CHAIN WHEEL OPERATORS FOR ALL VALVES IN EQUIPMENT ROOMS MOUNTED GREATER THAN 7'-0" ABOVE FINISHED FLOOR. CHAIN MUST EXTEND TO 7'-0" ABOVE FINISHED FLOOR LEVEL.</li> </ol> <p><u>CHEMICAL TREATMENT</u></p> <ol style="list-style-type: none"> <li>CHEMICAL FEED REQUIREMENTS - REFER TO THE POOL SYSTEMS SCHEMATIC(S) ON AQ2.0 &amp; AQ2.1.</li> <li>INTERLOCK POOL RECIRCULATION PUMP(S) WITH ITS CORRESPONDING WATER CHEMISTRY CONTROLLER, CHEMICAL FEED PUMP(S).</li> <li>PROVIDE SIGNAGE ON DOORS IN COMPLIANCE WITH THE FIRE CODE. REFER: 5/AQ1.3</li> <li>SECURE CHEMICAL METERING PUMP FEED LINES TO WALL AND/OR OVERHEAD WITH CLIPS OR DEVICES THAT DO NOT CRIMP, DISTORT OR ALLOW HIGH AND LOW AREAS IN TUBING RUNS. PROVIDE CHECK VALVE AND SHUT-OFF VALVE BEFORE LINES ENTER POOL RETURN PIPING.</li> <li>WATER CHEMISTRY CONTROLLERS MUST CONTROL THE SANITIZING SYSTEM AND PH CONTROL SYSTEM AND SHUT THEM DOWN UPON LOSS OF SAMPLE STREAM FLOW.</li> <li>THE CHEMICAL SENSOR LINE MUST BE A 3/4" TO 1" DIAMETER, SCHEDULE 80 PVC PIPE EXTENDED FROM THE WET CELL SENSOR TO ITS RESPECTIVE FILL FUNNEL AND THE BACKWASH CATCH BASIN OR PUMP SUCTION.</li> <li>SAMPLE FEED PIPING TO/FROM THE RECIRCULATION SYSTEM TO THE WATER CHEMISTRY CONTROLLER MUST BE PIPED PER THE SYSTEMS SCHEMATIC. BYPASS PIPING MUST BE SADDLED OR TEED. NO TAPPING OR DRILLING INTO THE PIPING WILL BE ALLOWED.</li> <li>INSTALL SANITIZER INJECTION POINT DOWNSTREAM OF PH BUFFER INJECTION POINT ON FILTERED WATER RETURN PIPE. CHEMICAL INJECTION POINTS MUST BE LOCATED DOWNSTREAM OF ALL OTHER EQUIPMENT/SYSTEMS IN THE POOL MECHANICAL ROOM AT A MAXIMUM HEIGHT OF 7'-0" ABOVE FINISHED FLOOR. REFER: 4/AQ1.3</li> </ol> <p><u>ELECTRICAL</u></p> <ol style="list-style-type: none"> <li>GFCIS PROVIDED AT OUTLETS. REFER TO ELECTRICAL.</li> <li>POOL EQUIPMENT ROOM AND CHEMICAL STORAGE AREAS MUST BE PROVIDED WITH ARTIFICIAL LIGHTING SUFFICIENT TO ILLUMINATE ALL EQUIPMENT AND SUPPLIES. REFER TO ELECTRICAL.</li> <li>CONDUIT MUST BE ROUTED OVERHEAD OR BELOW GRADE.</li> </ol>

FILTER SCHEDULE											
ID	POOL	MANUFACTURER	FILTER MODEL	QTY.	FILTRATION TYPE	MAXIMUM FILTRATION RATE (GPM/SQ. FT.)	DESIGN FILTRATION RATE (GPM/SQ. FT.)	REQUIRED FILTRATION AREA (SQ. FT.)	DESIGN FILTRATION AREA (SQ. FT.)	FILTER BACKWASH RATE (GPM/SQ. FT.)	BACKWASH FLOW RATE PER FILTER (GPM)
F1	LEISURE	NEPTUNE BENSON	SHFFG 42-48	2	HRS	12.5	10.96	30.0	34.2	15	257
F2	TOT	NEPTUNE BENSON	42CCFG-3	1	HRS	12.5	11.44	8.2	9.0	15	135
F3	HOT TUB	NEPTUNE BENSON	SHFFG 42-48	1	HRS	12.5	10.12	13.8	17.1	15	257
F4	COMPETITION	NEPTUNE BENSON	SHFFG 36-96	2	HRS	12.5	10.84	40.7	52.6	15	395

NOTE:  
 1. BACKWASH METHOD MUST BE MANUAL.  
 2. ALL FILTER SUPPORTS MUST BE SEISMICALLY RATED FOR THE SEISMIC ZONE IN WHICH IT IS INSTALLED IN ACCORDANCE WITH LOCAL AND/OR PROVINCIAL REQUIREMENTS.  
 3. FILTER MANUFACTURER MUST CERTIFY FILTER MEDIA.  
 4. THE BACKWASH PIPING MUST TERMINATE NO CLOSER THAN 6" ABOVE THE FLOOD RIM OF THE BACKWASH BASIN OR TWICE THE PIPE DIAMETER, WHICHEVER IS GREATER. COMPETITION POOL ONLY.  
 5. FILTER TANK ASSEMBLIES MUST BEAR THE NATIONAL SANITATION FOUNDATION SEAL OF APPROVAL FOR A MAXIMUM FLOW RATE 20 GPM PER SQUARE FOOT OF FILTER MEDIA.  
 6. THE BACKWASH THROTTLING VALVE(S) HANDLE MUST BE REMOVED AND TURNED OVER TO THE OWNER ONCE THE BACKWASH FLOW RATE(S) HAVE BEEN TESTED, ADJUSTED AND BALANCED.  
 7. PROVIDE 1" DIAMETER, SCHEDULE 80 PIPE FROM THE AUTOMATIC AIR VENT ON EACH OF THE FILTER VESSEL TO THE NEAREST FLOOR DRAIN OR BACKWASH CATCH BASIN. THE VENT PIPE MUST BE SLOPED TO THE DRAIN.  
 8. VALVES MUST BE PROVIDED TO BACKWASH EACH FILTER VESSEL INDEPENDENTLY.  
 9. VESSEL MUST BE BACKWASHED AT NO LESS THAN 15.0 GPM/SF.

ELECTRONIC FLOCCULATION SYSTEM SCHEDULE								
ID	POOL	MANUFACTURER	MODEL	PIPE SIZE (NOMINAL)	INPUT VOLTAGE	POWER RATING (W)	POWER CABLE LENGTH (FT)	SIGNAL CABLE LENGTH (FT)
E1	LEISURE	CLEAR-FLOW	CF-600C	6"	100-240 VAC	5.4	15	33
E2	TOT	CLEAR-FLOW	CF-300C	UP TO 3"	100-240 VAC	4	5	9
E3	HOT TUB	CLEAR-FLOW	CF-400C	4"	100-240 VAC	5.4	15	33
E4	COMPETITION	CLEAR-FLOW	CF-600C	6"	100-240 VAC	5.4	15	33

NOTE:  
 REFER: 3/AQ1.3



Drawn: KAS  
 Checked: CJR  
 Checked: CCH

No.	Description	Date
01	100% CD	06/15/2026





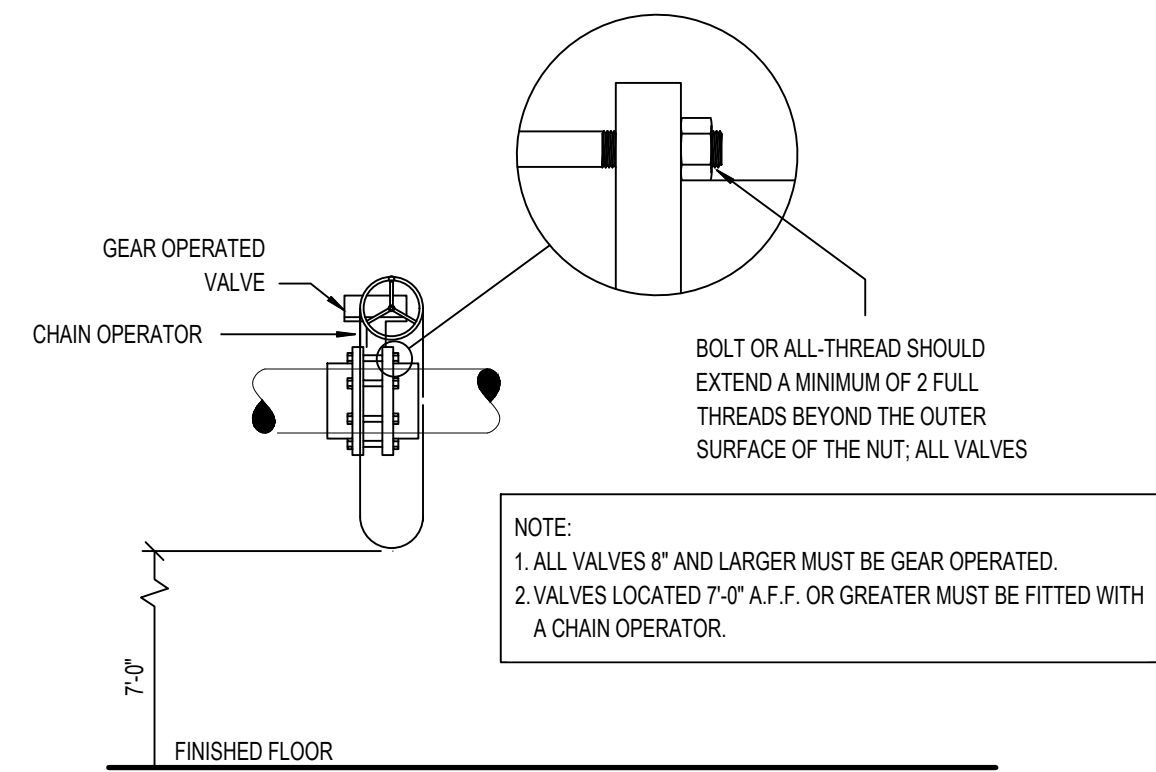

7 VALVE  
1/2" = 1'-0"

NOTE:  
1. CHEMICAL INJECTIONS MUST BE SCH 80 PVC SADDLES OR SCH 80 PVC TEE FITTINGS WITH REDUCER BUSHING.  
2. POOL CONTRACTOR CAN ELECT TO USE TEE FITTINGS WITH REDUCER BUSHINGS OR SCH 80 PVC SADDLES FOR BOTH THE PH CHEMICAL INJECTION AND THE SANITIZER INJECTION. CHEMICAL INJECTION MUST NOT BE TAPPED INTO RECIRCULATION PIPING.  
3. INSTALL SANITIZER INJECTION POINT DOWNSTREAM OF PH BUFFER INJECTION POINT. REFER TO SYSTEMS SCHEMATIC.

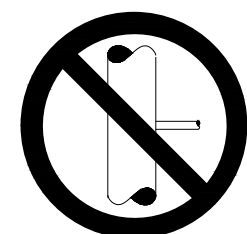

DO NOT DRILL AND TAP POOL PIPING

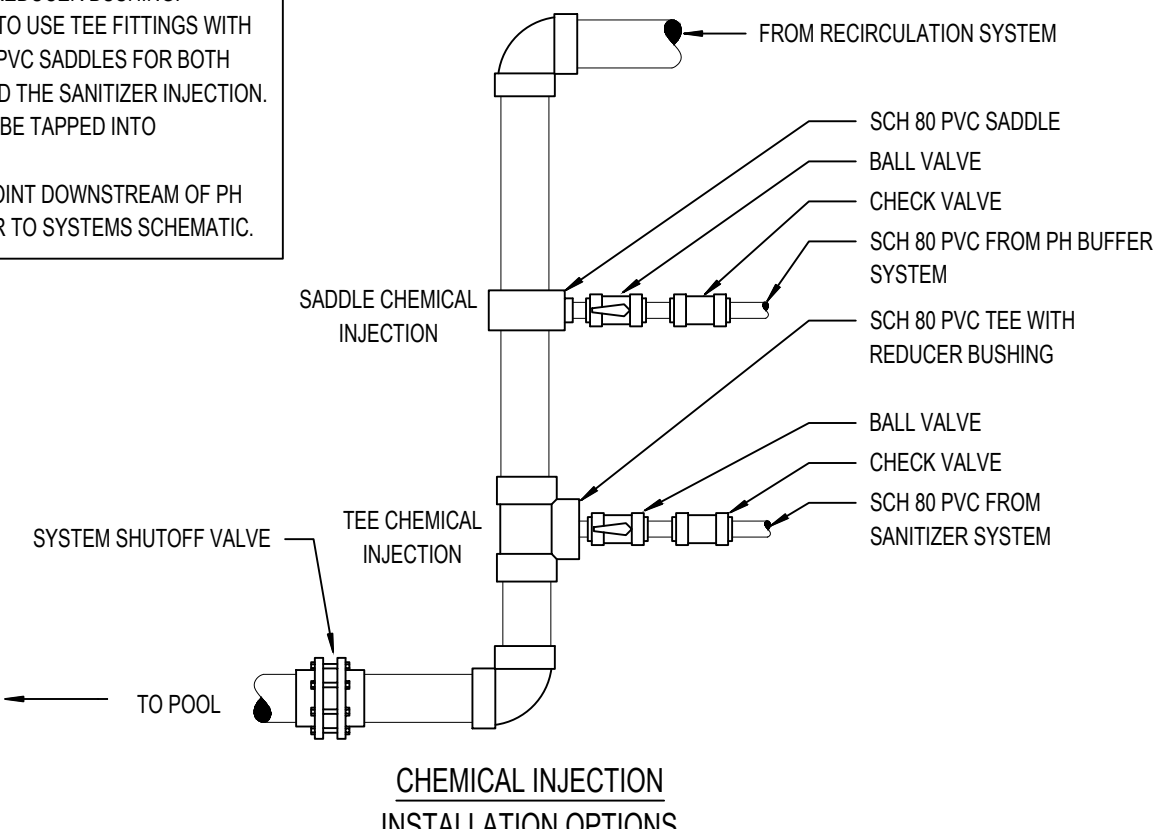

CHEMICAL INJECTION  
INSTALLATION OPTIONS

4 CHEMICAL INJECTION  
1/2" = 1'-0"

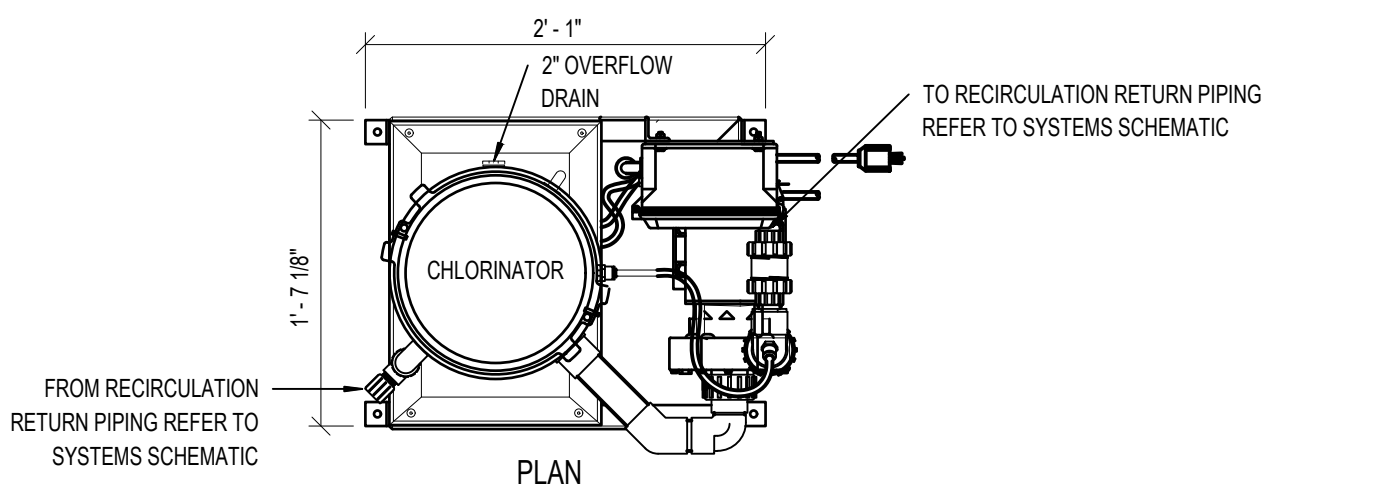

PLAN

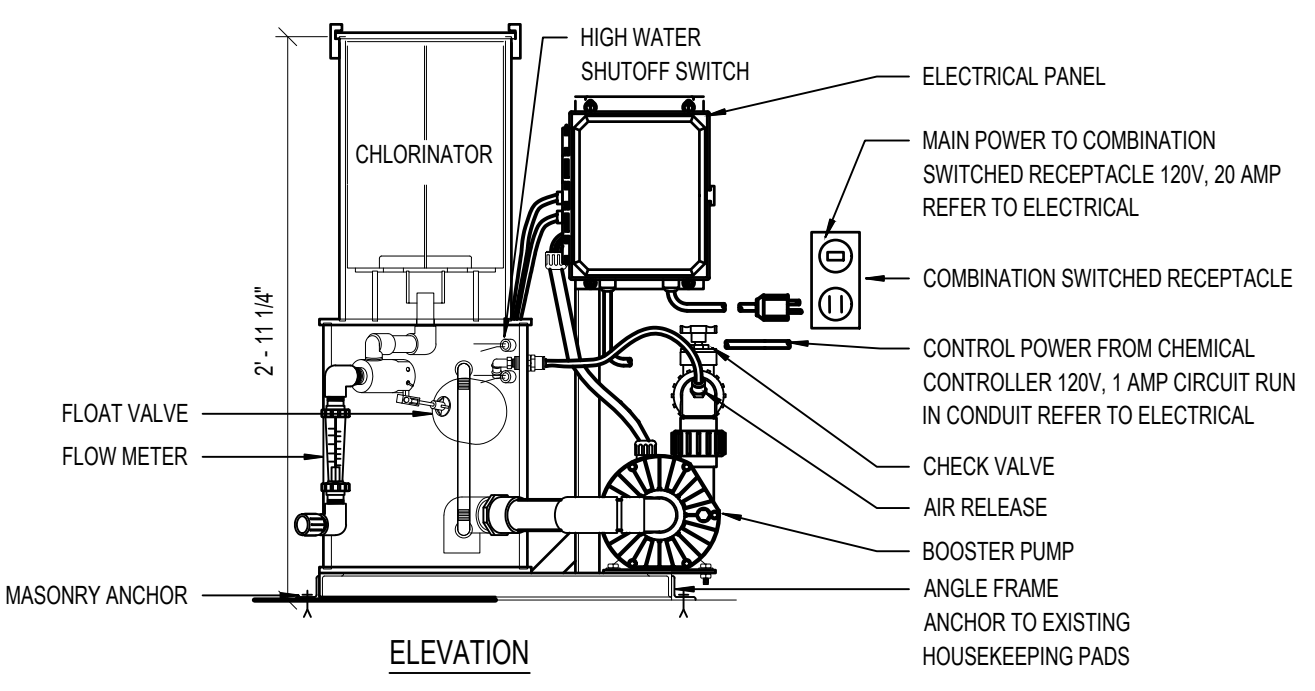

ELEVATION

1 CHLORINATION SYSTEM  
1" = 1'-0"

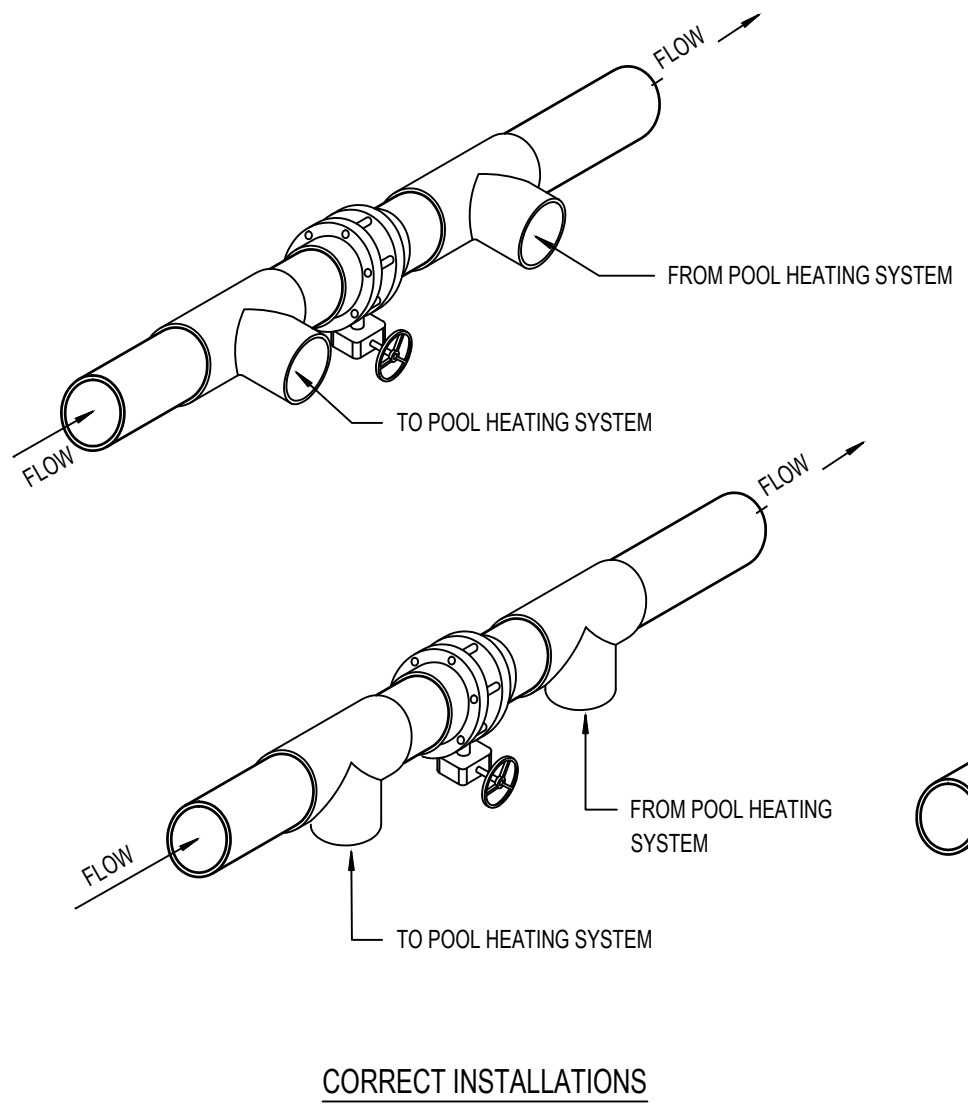

NOTE:  
INSTALL TEES IN A HORIZONTAL OR A DOWNWARD VERTICAL DIRECTION. TEES MUST NOT BE ORIENTED IN AN UPWARD DIRECTION.



INCORRECT INSTALLATION

CORRECT INSTALLATIONS

8 PIPING BYPASS  
NTS

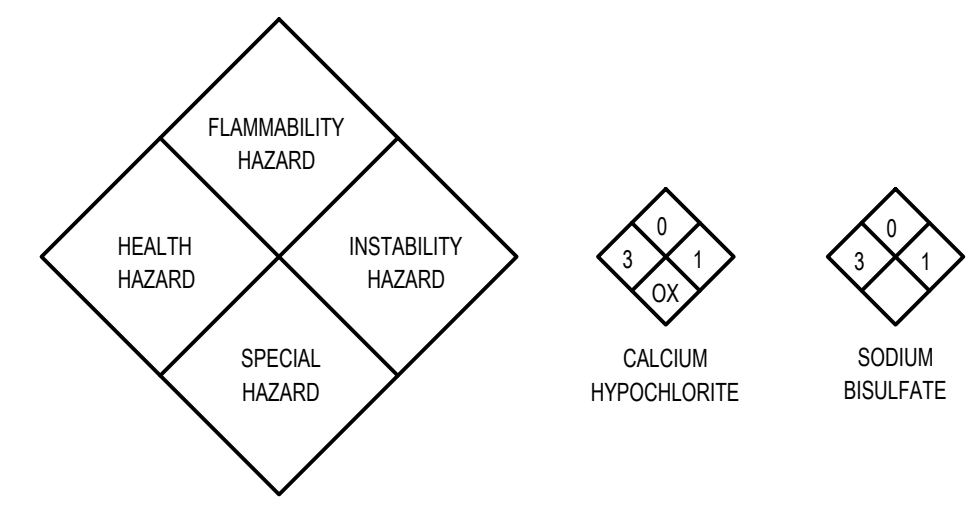

CALCIUM HYPOCHLORITE  
SODIUM BISULFATE

RATING EXPLANATION GUIDE			
RATING	HEALTH HAZARD	FLAMMABILITY HAZARD	INSTABILITY HAZARD
4	CAN BE LETHAL	BELOW 73 DEGREES F	MAY EXPLODE AT NORMAL TEMPERATURES & PRESSURES
3	CAN CAUSE SERIOUS OR PERMANENT INJURY	ABOVE 73 DEGREES, BELOW 100 DEGREES F	MAY EXPLODE AT HIGH TEMPERATURE OR SHOCK
2	CAN CAUSE TEMPORARY INCAPACITATION OR RESIDUAL INJURY	ABOVE 100 DEGREES, BELOW 200 DEGREES F	VIOLENT CHEMICAL CHANGE AT HIGH TEMPERATURES OR PRESSURES
1	CAN CAUSE SIGNIFICANT IRRITATION	ABOVE 200 DEGREES F	NORMALLY STABLE, HIGH TEMPERATURES MAKE UNSTABLE
0	NO HAZARD	WILL NOT BURN	STABLE

CONFIRM SIGNAGE WITH LOCAL FIRE MARSHAL, CHEMICAL SUPPLY COMPANY, AND/OR BUILDING CODES PRIOR TO INSTALLATION.

5 HAZARD SIGNAGE  
1" = 1'-0"

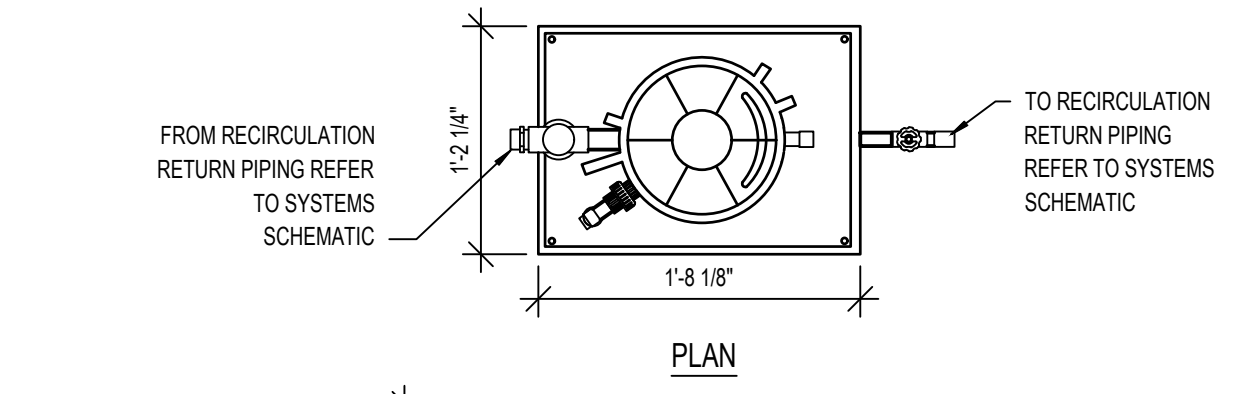

PLAN

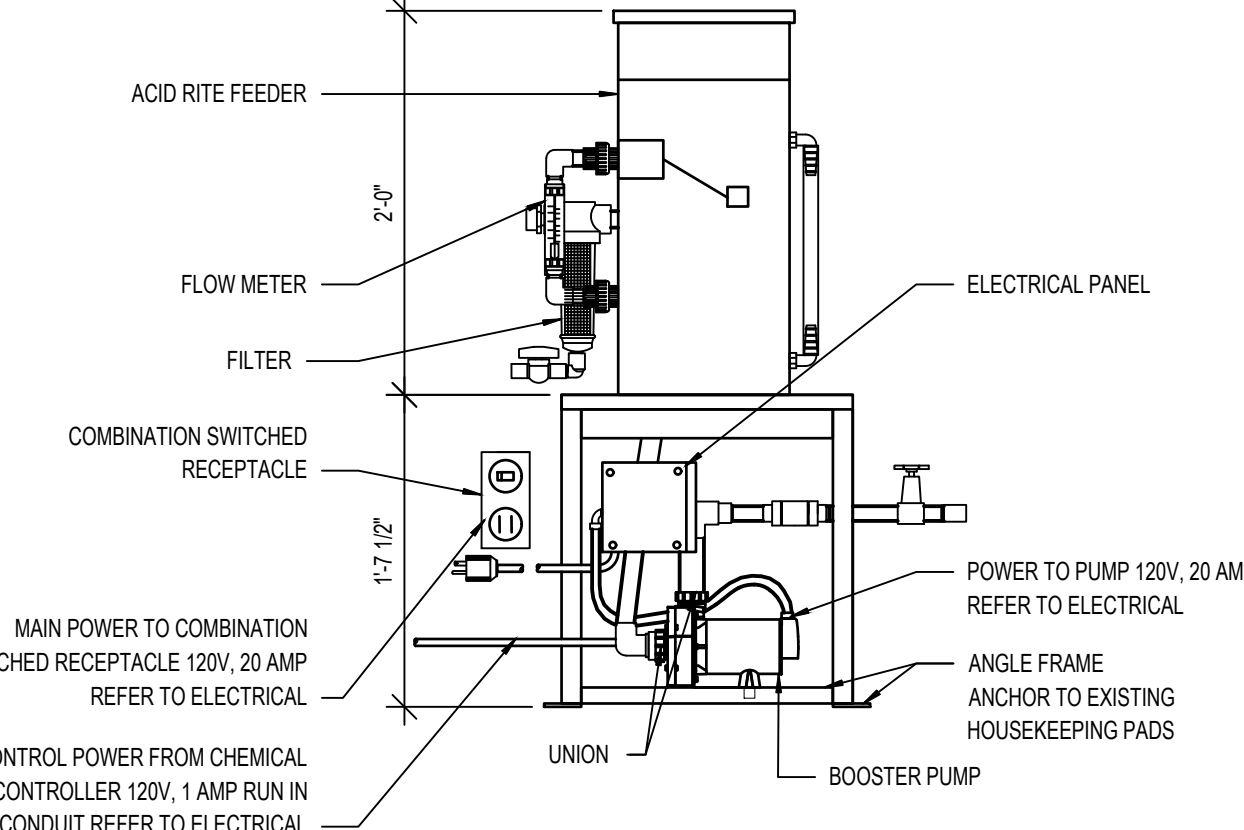

2 ACID SYSTEM  
1" = 1'-0"

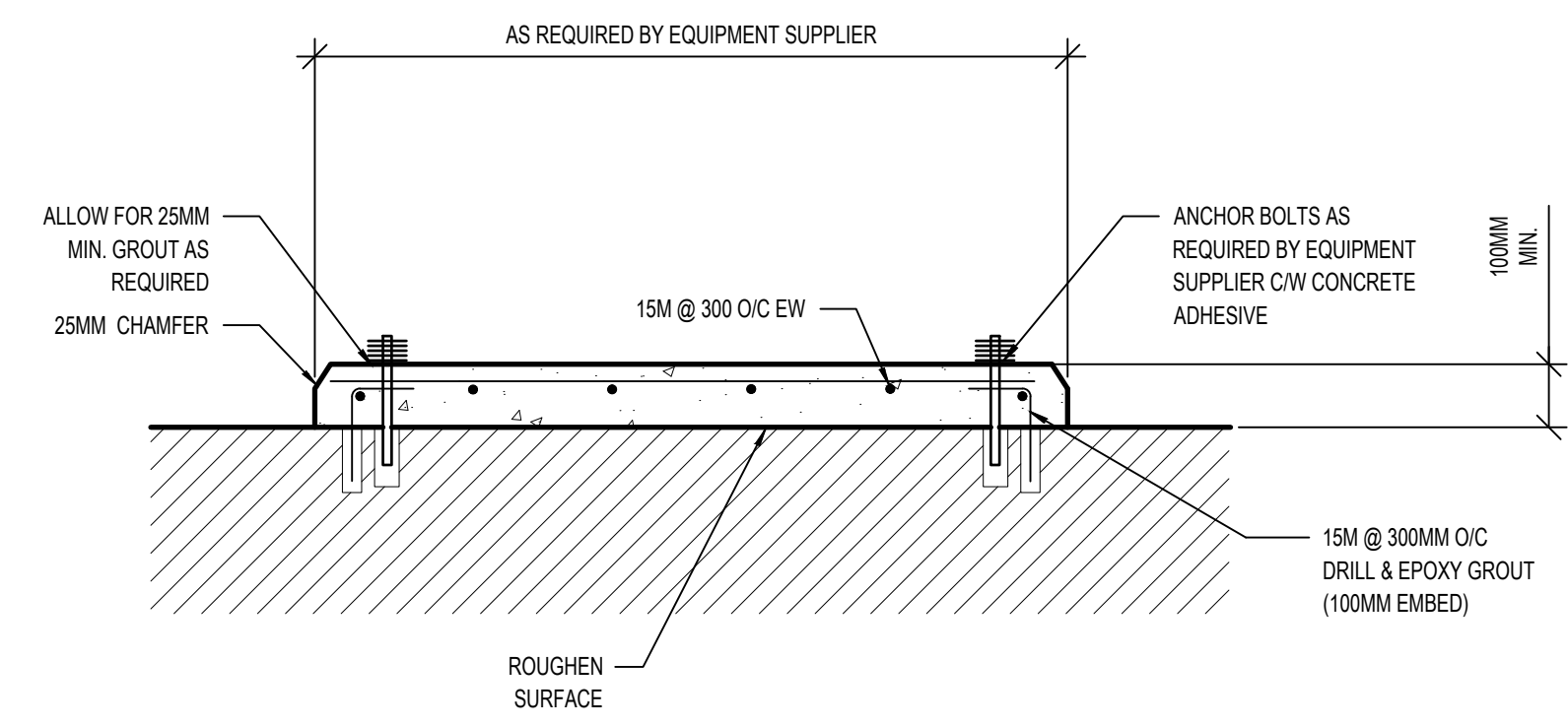

9 EQUIPMENT/HOUSEKEEPING PAD  
3" = 1'-0"

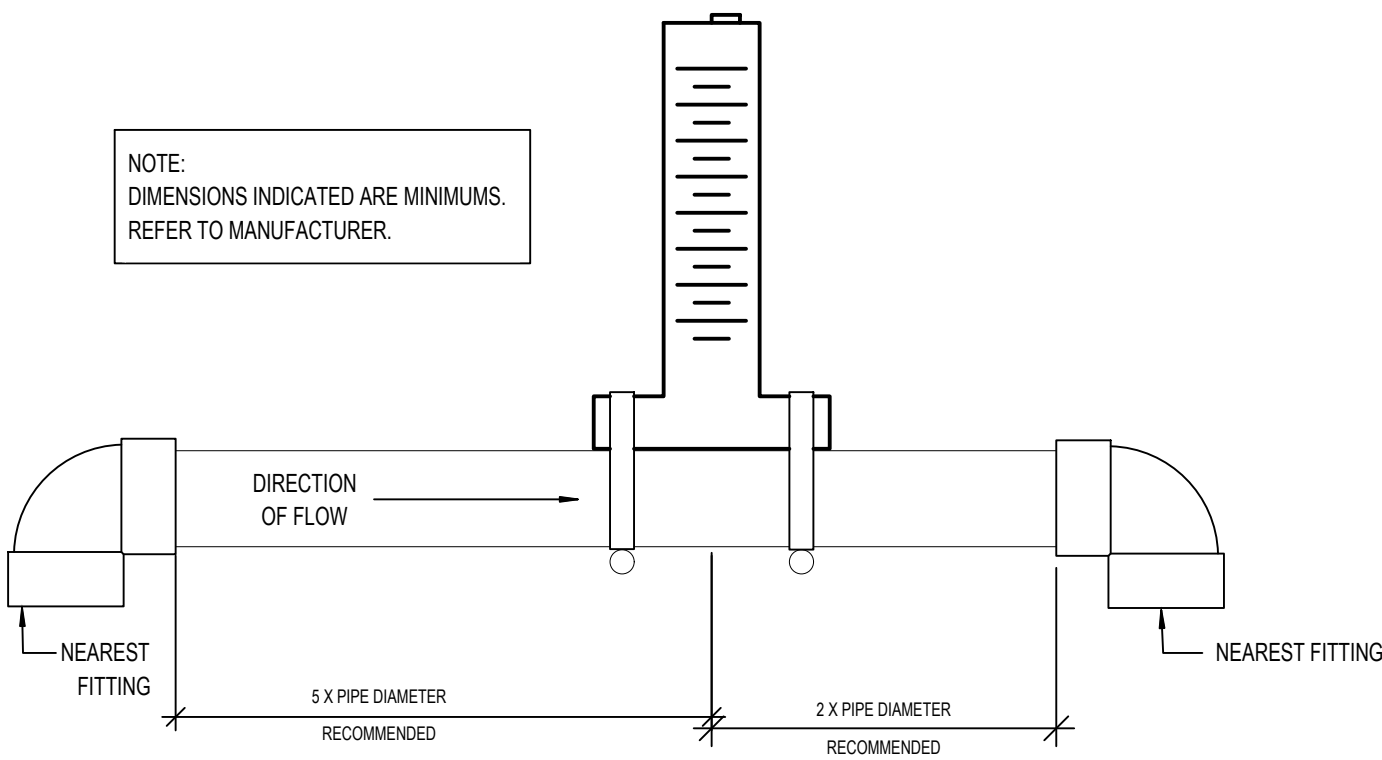

6 IMPACT FLOW METER  
3/4" = 1'-0"

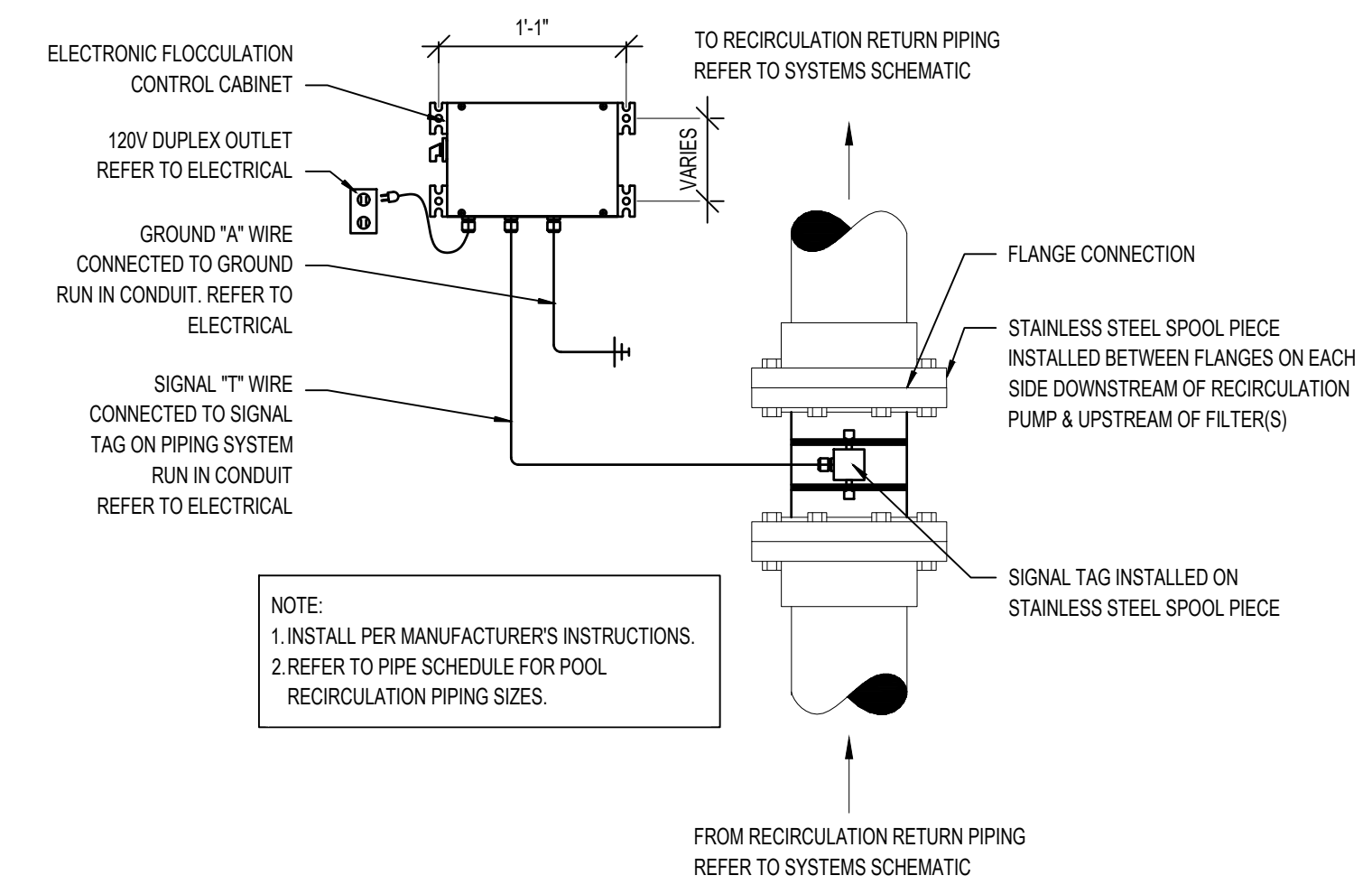

NOTE:  
1. INSTALL PER MANUFACTURER'S INSTRUCTIONS.  
2. REFER TO PIPE SCHEDULE FOR POOL RECIRCULATION PIPING SIZES.

3 ELECTRONIC FLOCCULATION SYSTEM  
1" = 1'-0"

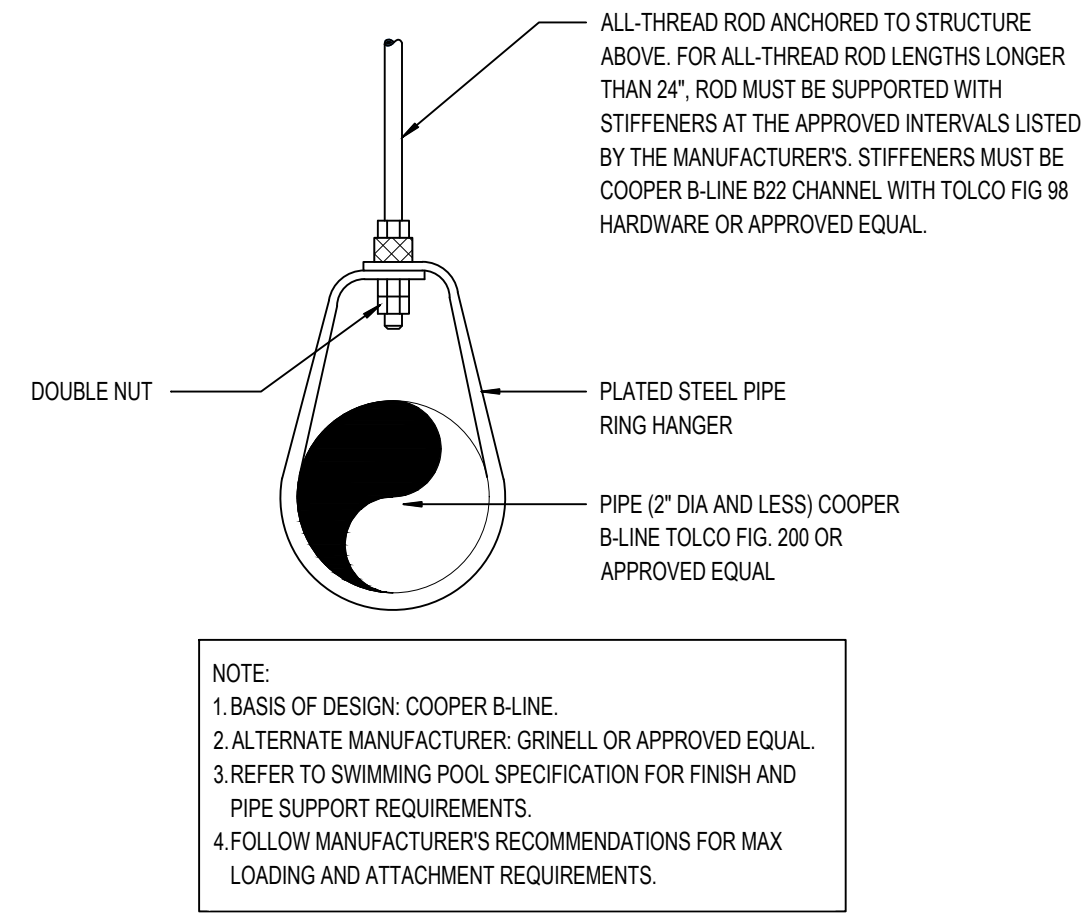

④ SWIVEL RING PIPE HANGER  
1 1/2\"/>

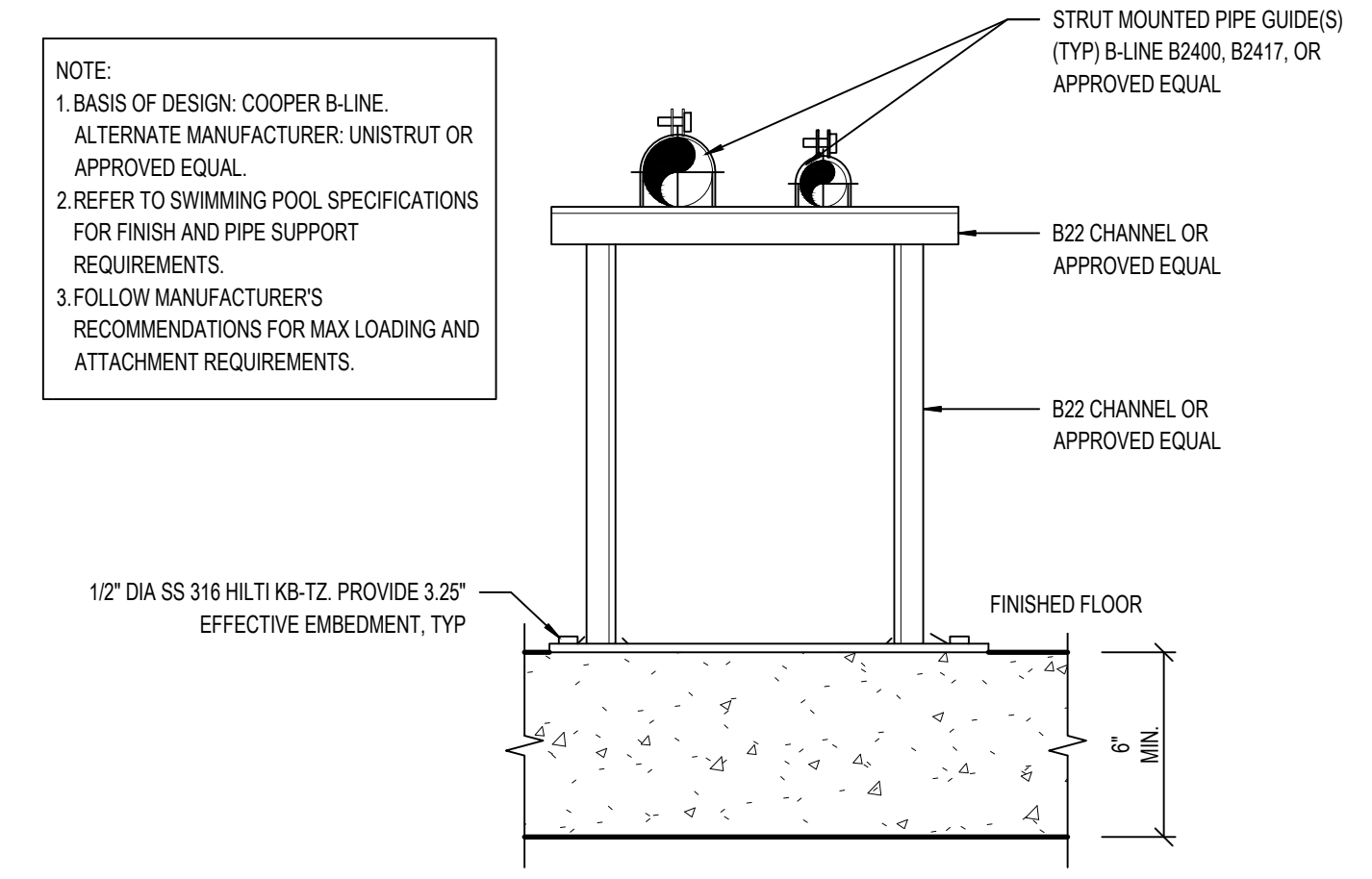

① ADJUSTABLE STRUT FLOOR MOUNTED  
3\"/>

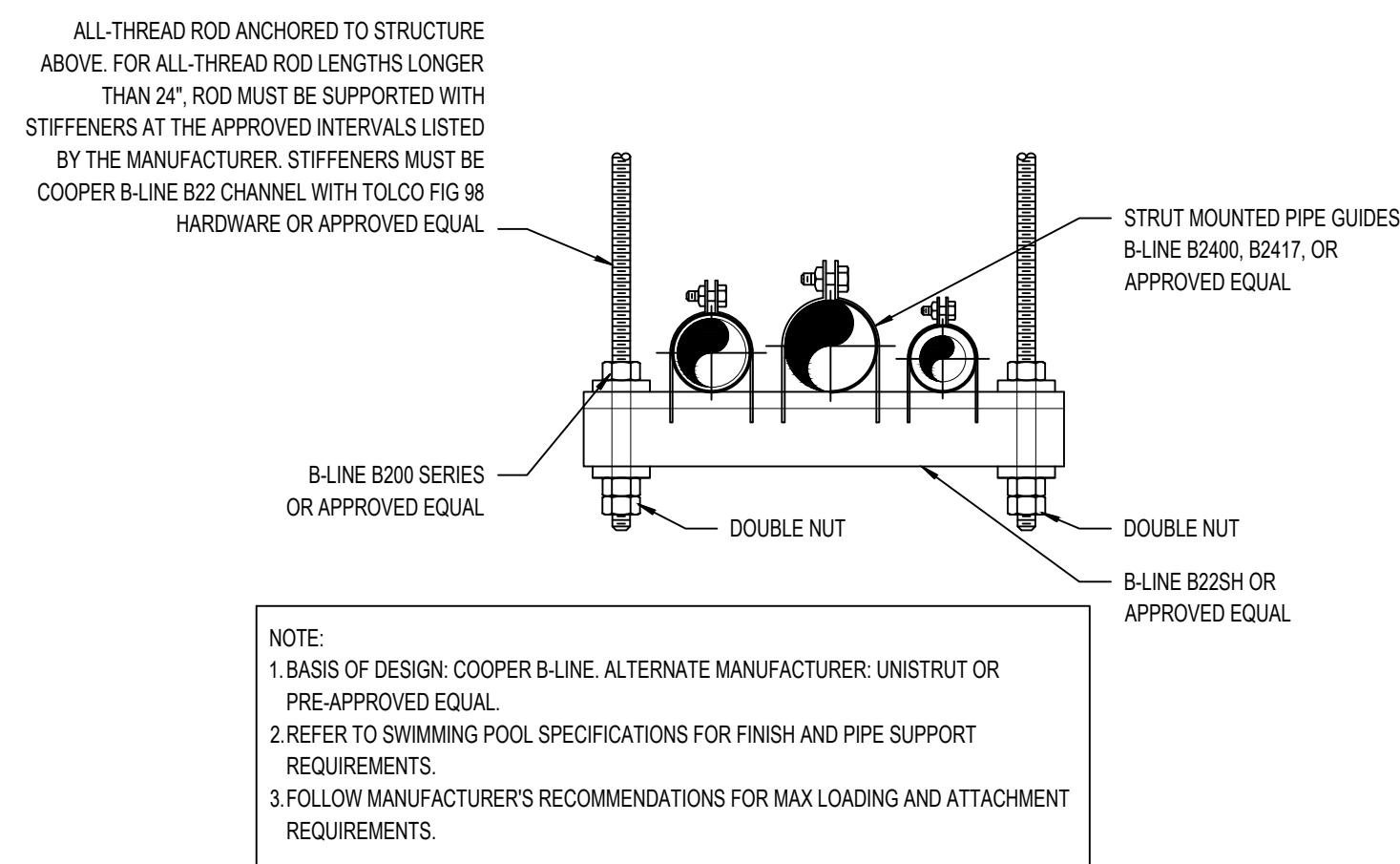

⑤ TRAPEZE HANGER  
3\"/>

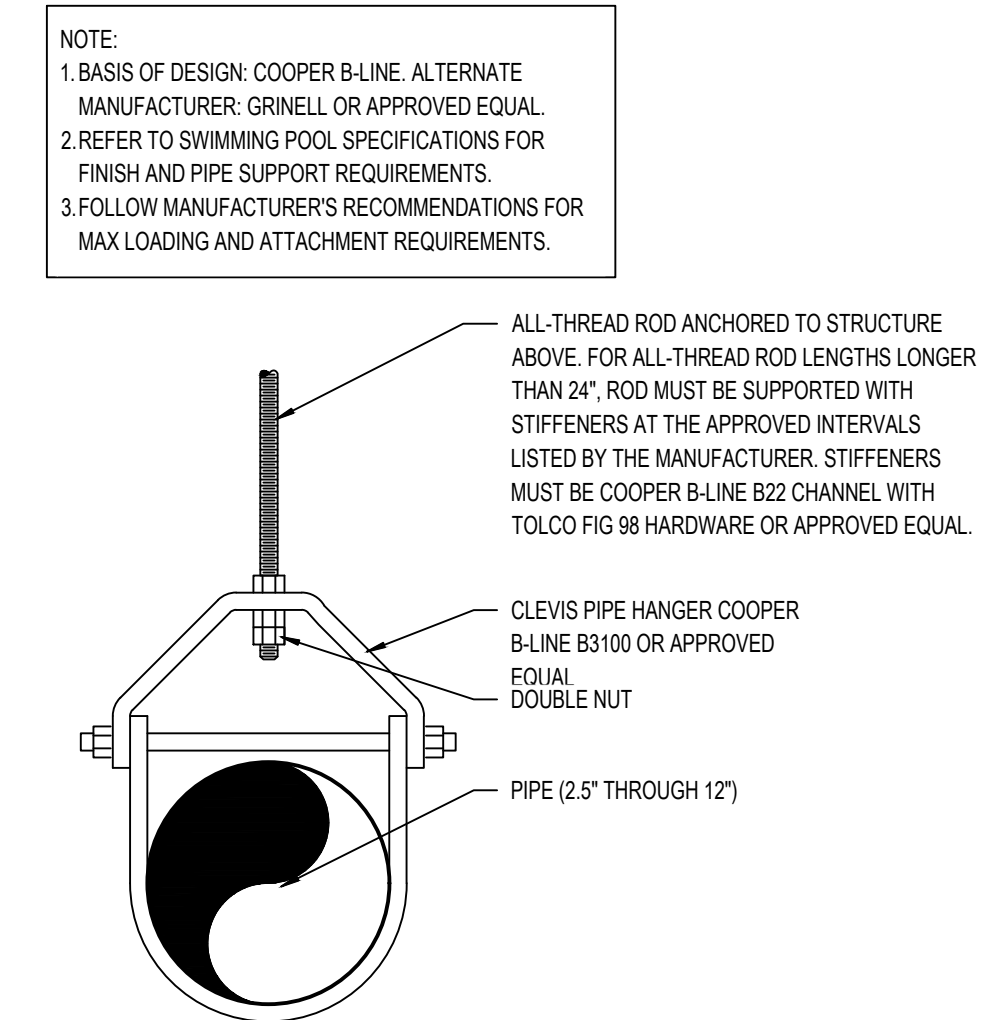

② CLEVIS PIPE HANGER  
1 1/2\"/>

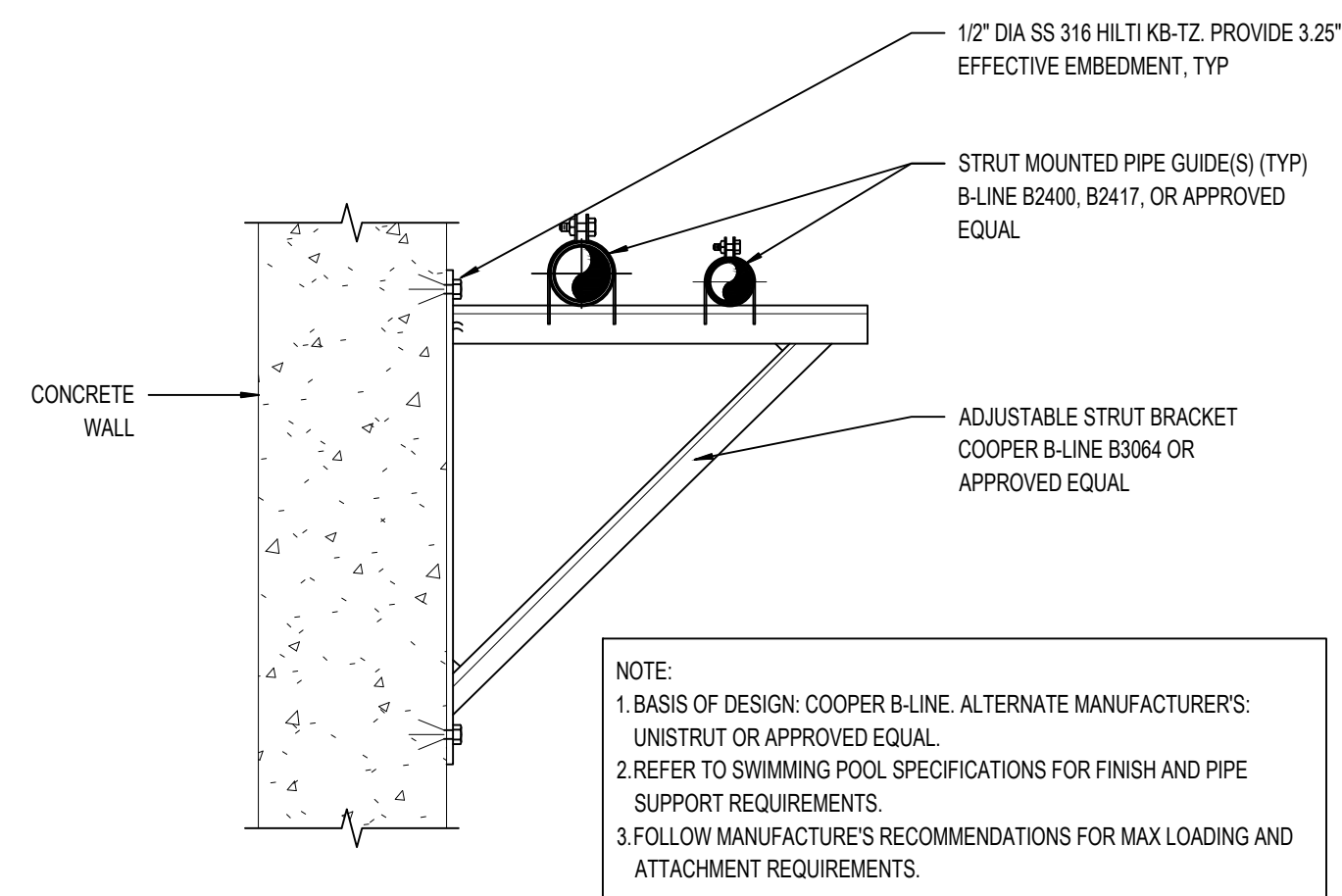

⑥ ADJUSTABLE STRUT BRACKET  
3\"/>

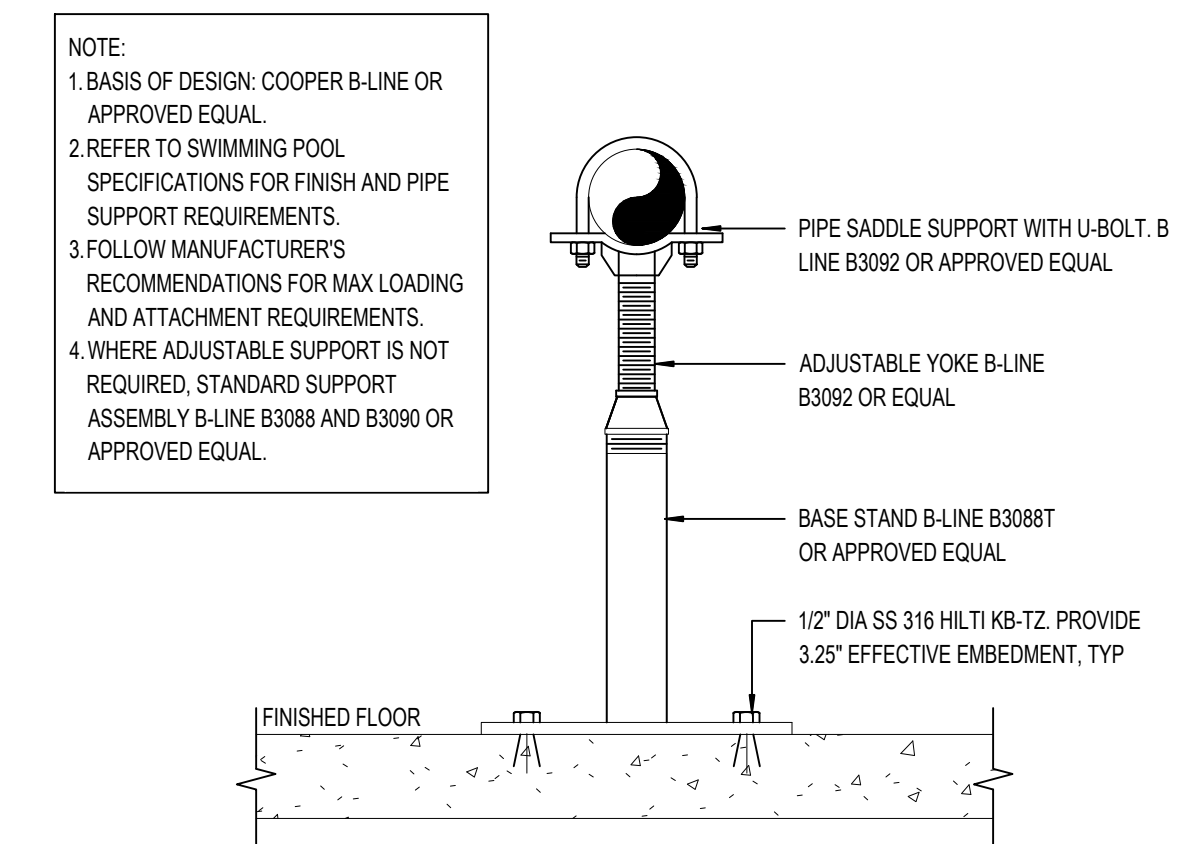

③ PIPE SUPPORT  
3\"/>

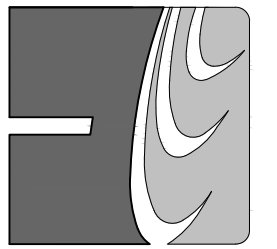

Professional Seal



Drawn: KAS  
Checked: CJR  
Checked: CCH

No.	Description	Date
01	100% CD	06/15/2026

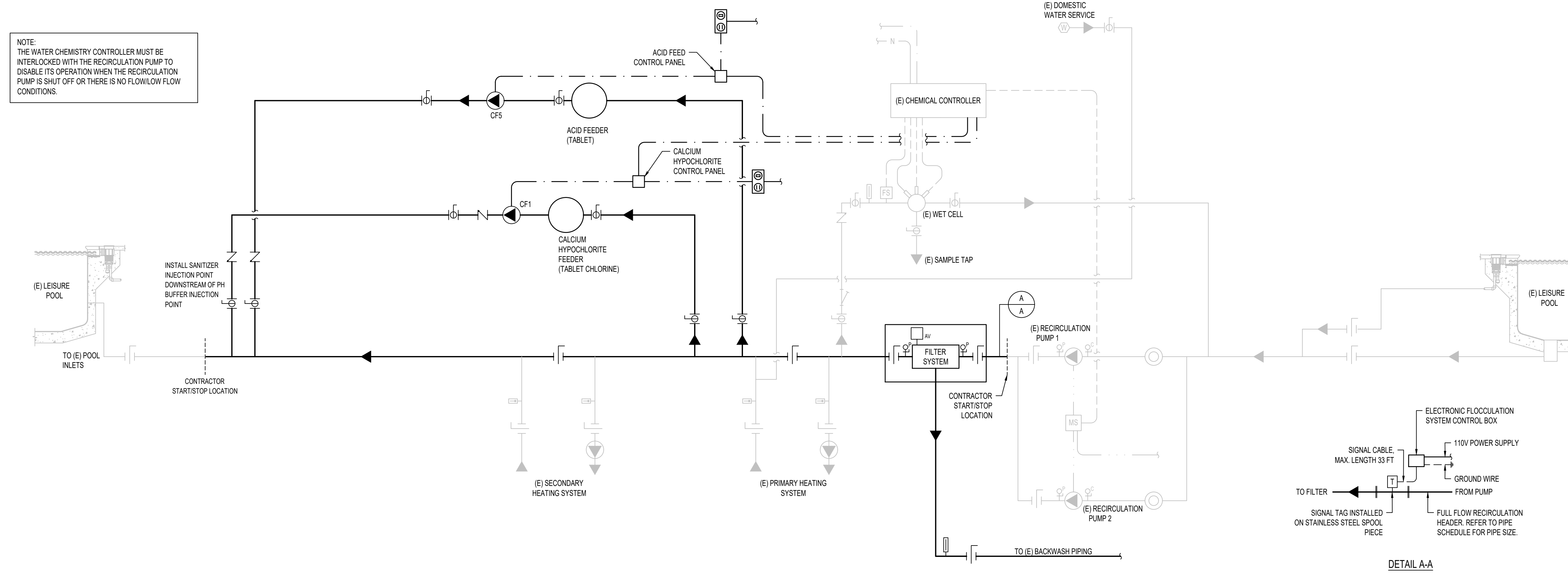

1 LEISURE POOL SYSTEMS SCHEMATIC NTS

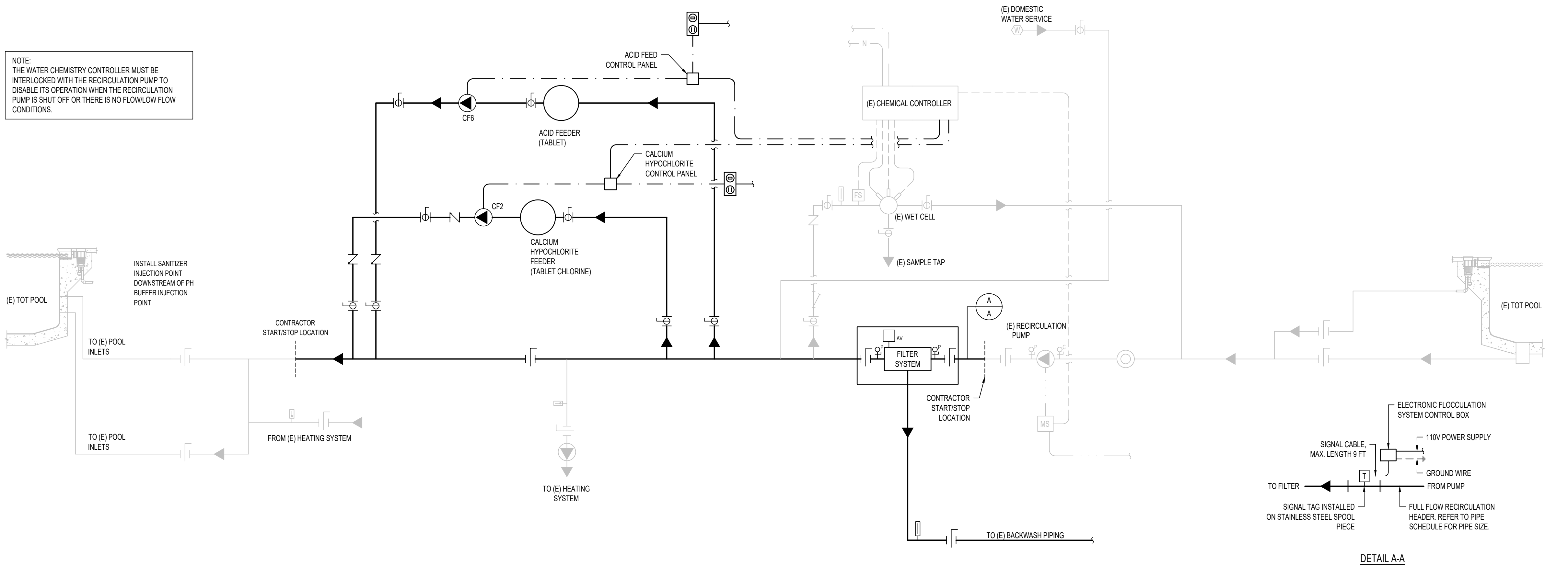

2 TOT POOL SYSTEMS SCHEMATIC NTS

**SCHEMATIC LEGEND**

LEGEND	ITEM
▲	FLOW DIRECTION
⌞	BUTTERFLY VALVE
⊘	BALL VALVE
⊘	MODULATING FLOAT VALVE
⊘	SOLENOID VALVE
⊘	CHECK VALVE
⊘	THREE WAY VALVE
⊘	PUMP
⊘	HAIR AND LINT STRAINER
⊘	"Y" STRAINER
⊘	IN-LINE UV STRAINER
FMS	FLOW METER SENSOR
FS	FLOW SWITCH
⊘	IMPACT FLOW METER
⊘	VENTURI FLOW METER
⊘	WATER METER
⊘	AUTOMATIC AIR VENT
⊘	AIR VENT
⊘	AIR INLET
⊘	PRESSURE GAUGE AND PETCOCK
⊘	COMPOUND GAUGE AND PETCOCK
⊘	DIGITAL TEMP SENSOR
⊘	THERMOMETER
⊘	PNEUMATIC ACTUATOR
⊘	FLOW CONTROL VALVE
⊘	COMBINATION SWITCH/RECEPTACLE
⊘	DUPLEX OUTLET
⊘	AUTOMATIC PUMP SHUT-OFF DEVICE
⊘	VARIABLE FREQUENCY DRIVE
⊘	REMOTE START/STOP
⊘	EMERGENCY STOP
⊘	VARIABLE FREQUENCY DRIVE BYPASS
⊘	MOTOR STARTER
⊘	ELECTRONIC FLOCCULATION SIGNAL TAG
⊘	15 MINUTE TIMER SWITCH
---	LOW VOLTAGE CONTROL
---	WATER LINE
---	1 PHASE POWER
---	3 PHASE POWER
---	CO <sub>2</sub> LINE
---	NETWORK LINE BY ELECTRICAL
---	GAS LINE



Drawn:	KAS	
Checked:	CJR	
Checked:	CCH	
No.	Description	Date
01	100% CD	06/15/2026

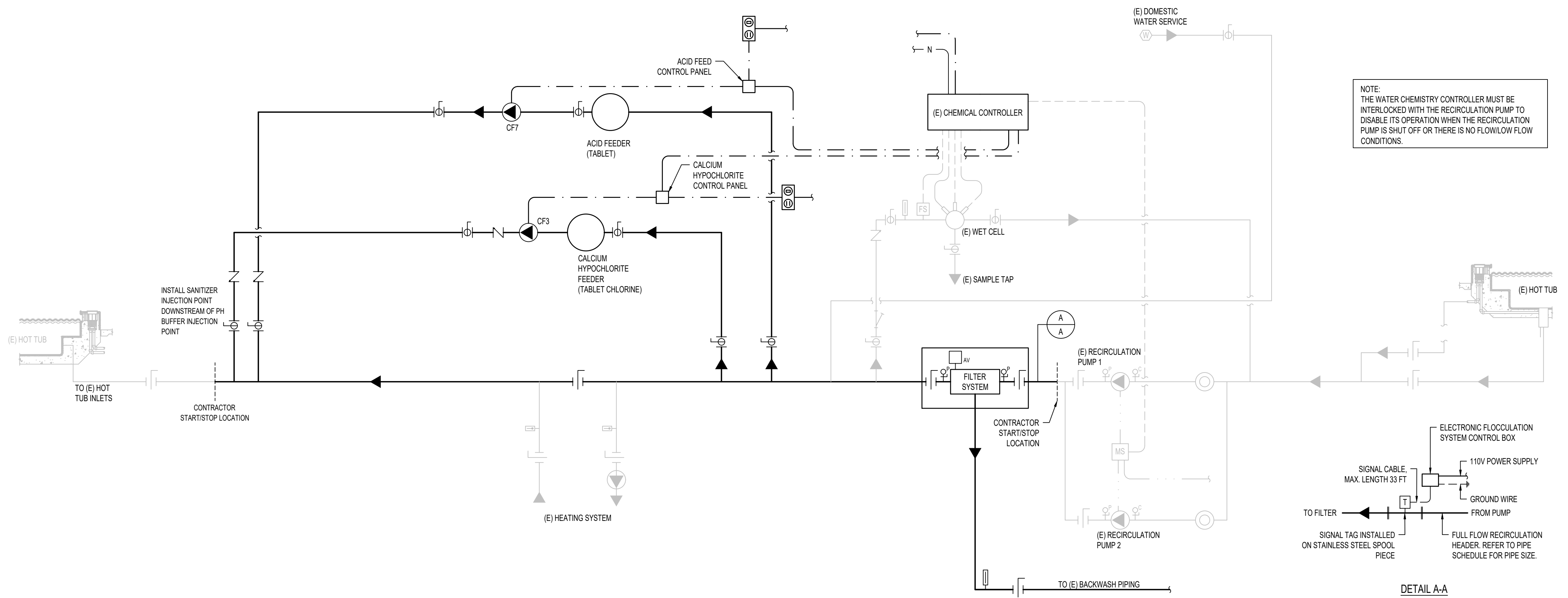

NOTE:  
THE WATER CHEMISTRY CONTROLLER MUST BE INTERLOCKED WITH THE RECIRCULATION PUMP TO DISABLE ITS OPERATION WHEN THE RECIRCULATION PUMP IS SHUT OFF OR THERE IS NO FLOW/LOW FLOW CONDITIONS.

DETAIL A-A

SCHEMATIC LEGEND	
LEGEND	ITEM
▲	FLOW DIRECTION
⊘	BUTTERFLY VALVE
⊚	BALL VALVE
⊚	MODULATING FLOAT VALVE
⊚	SOLENOID VALVE
⊚	CHECK VALVE
⊚	THREE WAY VALVE
⊚	PUMP
⊚	HAIR AND LINT STRAINER
⊚	"Y" STRAINER
⊚	IN-LINE UV STRAINER
FMS	FLOW METER SENSOR
FS	FLOW SWITCH
IFM	IMPACT FLOW METER
VFM	VENTURI FLOW METER
W	WATER METER
AV	AUTOMATIC AIR VENT
AV	AIR VENT
AV	AIR INLET
P	PRESSURE GAUGE AND PETCOCK
C	COMPOUND GAUGE AND PETCOCK
⊚	DIGITAL TEMP SENSOR
⊚	THERMOMETER
A	PNEUMATIC ACTUATOR
⊚	FLOW CONTROL VALVE
⊚	COMBINATION SWITCH/RECEPTACLE
⊚	DUPLEX OUTLET
AFSD	AUTOMATIC PUMP SHUT-OFF DEVICE
V	VARIABLE FREQUENCY DRIVE
R	REMOTE START/STOP
E	EMERGENCY STOP
BYP	VARIABLE FREQUENCY DRIVE BYPASS
MS	MOTOR STARTER
T	ELECTRONIC FLOCCULATION SIGNAL TAG
⊚	15 MINUTE TIMER SWITCH
---	LOW VOLTAGE CONTROL
---	WATER LINE
---	1 PHASE POWER
---	3 PHASE POWER
---	CO <sub>2</sub> LINE
N	NETWORK LINE BY ELECTRICAL
G	GAS LINE

1 HOT TUB SYSTEMS SCHEMATIC  
NTS

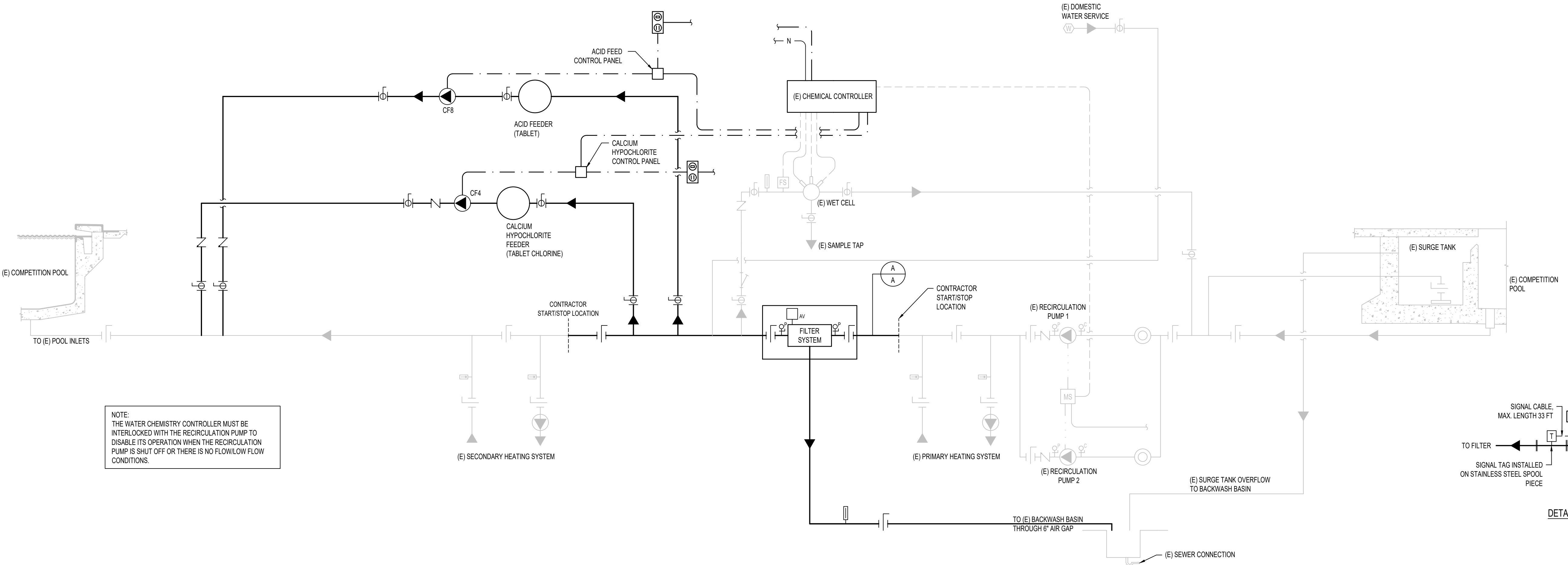

NOTE:  
THE WATER CHEMISTRY CONTROLLER MUST BE INTERLOCKED WITH THE RECIRCULATION PUMP TO DISABLE ITS OPERATION WHEN THE RECIRCULATION PUMP IS SHUT OFF OR THERE IS NO FLOW/LOW FLOW CONDITIONS.

DETAIL A-A

2 COMPETITION POOL SYSTEMS SCHEMATIC  
NTS



Drawn:	KAS	
Checked:	CJR	
Checked:	CCH	
No.	Description	Date
01	100% CD	06/15/2026