



Invitation to Tender

CITY OF KENORA

INVITATION TO TENDER / ADVERTISEMENT

Sealed Tenders for:
Bridge maintenance repairs across eighteen (18) bridge structures in Kenora

Tender Number: 312-003-26

Will be received
by:

City of Kenora
(the "City")

at:

1 Main Street South
Kenora, ON P9N 3X2
Attention: Kelly Galbraith, Deputy City Clerk

Time and date for Tender Closing is:

11:00:00 a.m. CST/CDT on June 25, 2026 (the "Tender Closing")

1. The work to be undertaken generally involves, but is not necessarily limited to: bridge repairs as set out in Part Four (4), attached to these Instructions to Tenders.
2. The CITY's consultant for the Project is Stantec.
3. The Successful Bidder shall achieve substantial performance of the Work for the Project by November 20, 2026.
4. The drawings and specifications for the Project can be obtained from Tino Mpofu, City of Kenora Project Manager, at tmpofu@kenora.ca.
5. All written inquiries regarding the technical aspects of the drawings and specifications for the Work shall be emailed to Tino Mpofu, City of Kenora Project Manager, at tmpofu@kenora.ca, however the bidder(s) acknowledge and agree that the CITY does not have an obligation to provide a response to any written inquiry and that it is in the sole and unfettered discretion of the CITY to provide any written response to a written inquiry. Telephone inquiries and email inquiries will not be replied to.
6. Submission of a tender by a Bidder gives the CITY the right to require the Bidder to execute the contract to perform the Work as set out within the tender documents. Tenders may not be withdrawn after the Tender Closing and will be irrevocable and open for acceptance by the CITY for a period of sixty (60) days following the end of the day of the Tender Closing. The Successful Bidder will be notified in writing of the award of the Tender when the CITY delivers a letter of intent to the Successful Bidder.



PART 1: INSTRUCTIONS TO TENDERERS

**CITY OF KENORA
Bride Maintenance Repairs
ITT# 312-003-26**

TABLE OF CONTENTS

PART 1 – INSTRUCTIONS TO TENDERERS

PAGES

1.1	Description	01-01
1.2	Submission of Tender	01-01
1.3	Tendering Details	01-01
1.4	Scope of Work	02-02
1.5	Tender Document review	02-02
1.6	Tender Form and Unit Price Schedule	02-03
1.7	Freedom of Information Act	03-03
1.8	Tender Documents	03-03
1.9	Variation in Tender Documents and No Implied Obligations	04-04
1.10	Addenda	04-04
1.11	Tender	04-05
1.12	Tender Deposit	05-05
1.13	Performance and Labour Material Bonds	05-06
1.14	Insurance	06-06
1.15	Relevant Experience & Project Team	06-06
1.16	Traffic Management Strategy	06-06
1.17	Work Schedule	06-07
1.18	Commencement and Completion of Work	07-07
1.19	Site Conditions	07-08
1.20	Prime Cost and Contingency Sums	08-08
1.21	Permits and Inspection	08-08
1.22	Successful Tenderer	08-08
1.23	Tender Evaluation Criteria	08-09
1.24	Workers' Compensation	09-10
1.25	Registration	10-10
1.26	Tenders Exceeding Budget	10-10
1.27	Certificate of Recognition ("C.O.R.") Safety Program Requirement	10-11
1.28	Canadian Free Trade Agreement	11-11
1.29	Acceptance or Rejection of Tenders	11-11
1.30	Law of Forum of Tender	11-11
1.31	Acceptance Period	12-12



1.32	Drawing List	12-12
------	--------------	-------

PART 1.1	CCDC 4 - 2023	13-43
-----------------	----------------------	--------------

PART 2 – TENDER FORMS	PAGES
------------------------------	--------------

Tender Form & Schedule of Prices	44-46
----------------------------------	-------

Appendices to Tender Form	46-46
---------------------------	-------

Supplements to Tender Form – Team Resumes	46-46
---	-------

Form C: Alternatives	47-47
----------------------	-------

Declaration Statement	48-48
-----------------------	-------

PART 3 – TECHNICAL SPECIFICATIONS	PAGES
--	--------------

01	General	49-59
----	---------	-------

02	Mobilization, Demobilization, and Site Work	60-60
----	---	-------

03	Traffic Control and Pedestrian Accommodation	61-64
----	--	-------

04	Concrete Repairs	65-84
----	------------------	-------

05	Supply and Place Reinforcing Steel	85-87
----	------------------------------------	-------

06	Supply and Installation of Galvanic Anodes	88-90
----	--	-------

07	Overhead Concrete Repairs	91-92
----	---------------------------	-------

08	Asphalt and Waterproofing Membrane Repair	93-97
----	---	-------

09	Timber Planks and Wood Treatment	98-100
----	----------------------------------	--------

10	Clear Vegetation from Embankments	101-101
----	-----------------------------------	---------

11	Bridge Joint Seal Replacement	102-105
----	-------------------------------	---------

12	Signage	106-107
----	---------	---------

13	Paving Stone Sidewalk Repairs	108-110
----	-------------------------------	---------

14	Cleaning Corroded Steel	111-111
----	-------------------------	---------

15	Wall Pack Light Replacement	112-112
----	-----------------------------	---------

16	Waste Transfer Station Repairs	113-114
----	--------------------------------	---------

17	Miscellaneous Maintenance	115-117
----	---------------------------	---------

18	Utility Conduit Repair	118-118
----	------------------------	---------

19	Glued Laminated Timber Repairs	119-119
----	--------------------------------	---------

20	Measurement and Payment	120-126
----	-------------------------	---------



APPENDICES

Appendix A – Kenora Health & Safety Policy

Appendix B – DFO Interim Code of Practice

Appendix C – Drawings

Appendix D – Tender Checklist



SECTION 1 INSTRUCTIONS TO TENDERERS

1.1 DESCRIPTION

- .1 The City of Kenora (the "CITY") is seeking tenders for **Bridge Maintenance Repairs** (the "Work") as more particularly set out in Part 3 – Technical Specs and Appendix "A" & "C" attached to these Instructions to Tenderers.

1.2 SUBMISSION OF TENDERS

- .1 The CITY will receive sealed tenders until: **11:00:00 A.M. CDT Thursday June 25, 2026** ("Tender Closing").
- .2 Each Tender shall be addressed to the CITY in a sealed envelope clearly marked with the Tenderer's name, address and tender number. The sealed envelope containing the Tender shall be delivered before the Tender Closing to the CITY in accordance with the Invitation to Tender and the Instructions to Tenderers at:

**City of Kenora
1 Main Street South
Kenora, ON P9N 3X2
Attention: Kelly Galbraith, Deputy City Clerk**

- .3 Emailed and faxed tenders will NOT be accepted and will be returned to the Tenderer unopened.
- .4 Inquiries are permitted until **Wednesday June 17, 2026, at 16:00:00 CDT** and are to be directed to the below via email.
 - a. David MacLaggan
David.MacLaggan@stantec.com

CC
 - b. Tino Mpofu
tmpofu@kenora.ca
- .5 The deadline for issuance of addenda by the City or the Consultant shall be **Friday June 19, 2026, at 16:30:00 CDT**. Any addenda posted after this date shall result in an extension to the tender closing date by an equal number of days.
- .6 In the event of a dispute or issue about whether or not a tender complies with the Instructions to Tenderers, the Consultant reserves the right to retain and open a copy of the tender in question in order to seek and obtain a legal opinion in relation thereto. The opening of a tender does not in any way constitute an admission by the Consultant as to the compliance, or not, of the subject tender.

1.3 TENDERING DETAILS

- .1 Digital copies of the tender and addenda documents will be posted on the City of Kenora Website and on MERX.
 - a. The Owner is City of Kenora
 - b. The Consultant is Stantec Consulting Ltd.
 - i. Note the term Consultant and Contract Administrator shall both be read to mean the party providing contract administration services for the Work.

1.4 SCOPE OF WORK

- .1 The work to be done under the Contract shall include the labour, equipment, and materials required to complete the maintenance works specified in the Contract documents. This work generally consists of, but is not limited to, the following:
 - a. Mobilization, demobilization, and site work.
 - b. Provision for design and implementation of temporary traffic control and pedestrian accommodation as needed.
 - c. Provision for design and implementation of temporary access scaffolding and/or platforms.
 - d. Concrete repairs.
 - e. Asphalt and waterproofing membrane repairs.
 - f. Bridge surface, joint, and embankment cleaning.
 - g. Timber plank replacement.
 - h. Clearing of vegetation on embankments.
 - i. Joint repairs.
 - j. Installation of new signs.
 - k. Paving stone sidewalk repairs.
 - l. Cleaning corroded steel.
 - m. Replacing lights, beacon, and light pole assemblies.
 - n. Miscellaneous bolt maintenance/replacement.
 - o. Steel edge armouring repair.
 - p. Miscellaneous maintenance.
 - q. Pressure grouting.
 - r. Utility conduit repairs.
 - s. Removal of all containment tarps, platforms and scaffolding.
 - t. Final site clean up.

1.5 TENDER DOCUMENT REVIEW

- .1 Investigate the drawings and local conditions prior to providing a tender.
- .2 Compare tender documents to existing work in-place conditions and report any discrepancies to the Consultant.
- .3 Tender documents examination can be obtained at the following locations as noted below:
 - a. MERX
 - b. City of Kenora Website

1.6 TENDER FORM AND UNIT PRICE SCHEDULE

- .1 Each Tenderer shall submit a complete tender on the Tender Form and Unit Price Schedule which forms part of the Tender Documents with the blank spaces filled in. The tender sum must be written in words as well as figures, and must be for a sum in Canadian Dollars including all tariffs, freight, duties and taxes other than the Harmonized Sales Tax which must be shown as a separate amount unless otherwise specifically stipulated (hereinafter referred to as the "Tender Sum"). In the event of a discrepancy between an amount written in words and an amount written in figures, the amount written in words shall be deemed the intended amount. Tenders shall be written in English.
- .2 The Tender Form and Unit Price Schedule must be completed in their entirety. All blank spaces shall be filled with a numerical value or text, as applicable. The entry of "zero" or "\$0.00" in any field within the Tender Form or Unit Price Schedule shall be deemed an acceptable response and shall not, in and of itself, render the Tender incomplete.

- .3 Notwithstanding the foregoing, the City shall be entitled to accept a Tender in such form as the City in its sole and unfettered discretion deems acceptable irrespective of irregularities whether of a trivial or substantial nature, or whether the Tender is noncompliant in a trivial or substantial manner.
- .4 The City shall not be obligated to accept Tenders that are unsigned, incomplete, conditional, illegible, unbalanced, obscure, contain irregularities of any kind, or contain mathematical or calculation errors of any kind. On Unit Price Tenders, if there is a discrepancy found between the unit price and the extended amount, the unit price shall be deemed to represent the intention of the Tenderer. Discrepancies between words and figures will be resolved in favour of the words. Discrepancies between the indicated sum of any figures and the correct sum thereof will be resolved in favour of the correct sum. Any discrepancies between the Tender Form and a post Tender Closing submission required by the Tender Documents will be resolved in favour of the post Tender submission.
- .5 Tenders shall not be withdrawn, modified or clarified after being delivered in accordance with the Tender Documents unless such withdrawal, modification or clarification is made in writing and actually received by Kelly Galbraith, Deputy City Clerk prior to the Tender Closing. Any withdrawal, modification or clarification of the Tender must be followed by a letter of confirmation signed and sealed in the same manner as the Tender and delivered to the address for the City in the Invitation to Tender within 48 hours of the Notice of the Withdrawal, Modification or Clarification.

1.7 FREEDOM OF INFORMATION AND PROTECTION OF PRIVACY ACT

- .1 All documents submitted to the CITY will be subject to the protection and disclosure provisions of Ontario's Freedom of Information and Protection of Privacy Act ("FOIP"). FOIP allows persons a right of access to records in the CITY's custody or control. It also prohibits the CITY from disclosing the Tenderer's personal or business information where disclosure would be harmful to the Tenderer's business interests or would be an unreasonable invasion of personal privacy as defined in sections 1.20 and 1.24 of FOIP. Tenderers are encouraged to identify what portions of their submissions are confidential and what harm could reasonably be expected from its disclosure. However, the CITY cannot assure Tenderers that any portion of the Tenderer's documents can be kept confidential under FOIP.

1.8 TENDER DOCUMENTS

- .1 The documents for the tender are:

- Cover Sheet
- Invitation to Tender and Instructions to Tenderers, Part 1
- Proposed CCDC 4 – 2023 Contract
- Tender Forms and Schedule of Prices, Part 2
- Technical Specifications, Part 3
- Appendix A – City of Kenora Health & Safety Policy
- Appendix B – Fisheries and Oceans Canada: Code of Practice
- Appendix C – Drawings
- Appendix D – Tender Submission Checklist
(hereinafter collectively referred to as the "Tender Documents")

By submitting its Tender, the Tenderer acknowledges and agrees that it has received and reviewed the Tender Documents.

1.9 VARIATION IN TENDER DOCUMENTS AND NO IMPLIED OBLIGATIONS

- .1 The Tenderer shall carefully examine the Tender Documents. Any errors, omissions, discrepancies or clauses requiring clarification shall be reported in writing to the CITY at least 7 working days prior to the Tender Closing. Where necessary the CITY shall respond to reported errors, omissions, discrepancies or clauses requiring clarification by way of Addenda.
- .2 Should a Tenderer fail to report any such errors, omissions, discrepancies or clauses requiring clarification at least 7 working days prior to the Tender Closing, the CITY shall be the sole judge as to the intent of the Tender Documents.
- .3 No implied obligation of any kind by or on behalf of the CITY shall arise from anything in the Tender Documents, and the express covenants and agreements contained in the Tender Documents and made by the CITY, are and shall be the only covenants and agreements that apply.
- .4 Without limiting the generality of Article 1.9.3, the Tender Documents supersede all communications, negotiations, agreements, representations and warranties either written or oral relating to the subject matter of the Tender made prior to the Tender Closing, and no changes shall be made to the Tender Documents except by written Addenda.

1.10 ADDENDA

- .1 Any changes to the Tender shall be in writing in the form of Addenda. Any Addenda issued to the Tender shall form part of the Tender Documents, whether or not the receipt of same has been acknowledged by a Tenderer, and the cost for doing the work therein shall be included in the Tender Sum. Verbal representations shall not be binding on the CITY nor form part of the Tender Documents. Technical inquiries into the meaning or intent of the Tender Documents must be submitted in writing to the persons identified in Article 1.2.3 of the Instructions to Tenderers.

1.11 TENDER

- .1 Tenderers submitting Tenders shall be actively engaged in the line of work required by the Tender Documents and shall be able to refer to work of a similar nature performed by them. They shall be fully conversant with the general technical phraseology in the English language of the lines of work covered by the Tender Documents.
- .2 Each Tenderer shall review the Tender Documents provided by the CITY and confirm that it is in possession of a full set of Tender Documents when preparing its Tender.
- .3 Tenders shall be properly executed in full compliance with the following requirements:
 - a. The signatures of persons executing the Tender must be in their respective handwriting; and
 - b. If the Tender is made by a limited company, the full name of the company shall be accurately printed immediately above the signatures of its duly authorized officers and **the corporate seal shall be affixed**;
 - c. If the Tender is made by a partnership, the firm name or business name shall be accurately printed above the signature of the firm and the Tender shall be signed by a partner or partners who have authority to sign for the partnership;
 - d. If the Tender is made by an individual carrying on business under the name other than its own, its business name together with its name shall be printed immediately above its signature or

- e. If the Tender is made by a sole proprietor who carries on business in its own name, the proprietor shall print its name immediately below its signature.
- .4 Tenders received from agents representing principals must be accompanied by a Power of Attorney signed by the said principals showing that the agents are duly authorized to sign and submit the Tender and have full power to execute the Contract on behalf of their principals. The execution of the Contract will bind the principals and have the same effect as if it were duly signed by the principals.

1.12 TENDER DEPOSIT

- .1 The Tenderer is required to submit with its Tender, a Consent of Surety and a Bid Bond in a form acceptable to the CITY, or in lieu of a Bid Bond, a Tenderer may submit, along with a Consent of Surety, a certified cheque or an irrevocable letter of credit in favour of the CITY equal to 10% of the Tender Sum as a guarantee that, if awarded the contract for the Work, the Tenderer will execute a contract and the Labour and Material Payment, and Performance Bonds referred to in Article 1.13 within the specified time frames.
- .2 The Bid Bonds, certified cheques or irrevocable letters of credit of the unsuccessful Tenderers shall be returned as soon as possible after the Contract has been duly executed by the Successful Tenderer.
- .3 The CITY will not pay any interest on money furnished as security.
- .4 The Bid Bond and Consent of Surety shall be issued by a Surety Company licensed in the Province of Ontario and satisfactory to the CITY.

1.13 PERFORMANCE AND LABOUR MATERIAL BONDS

- .1 The Successful Tenderer shall be required to furnish at its own expense a Performance Bond and Labour and Materials Payment Bond. For the purposes of this Article, both of these bonds shall be referred to as the "Bonds".
- .2 The Performance Bond shall guarantee the faithful performance of the Contract, and in default thereof, shall protect the CITY against any losses or damage arising by reason of failure of the Successful Tenderer to faithfully perform the Contract.
- .3 The Bonds are to be issued by a Surety Company licensed in the Province of Ontario and satisfactory to the CITY in the amount of 50% of the Contract Price for the Performance Bond and 50% of the contract price for the Labour and Materials Payment Bond.
- .4 The Performance Bond shall remain in force as a Maintenance Bond for the Warranty Period as defined in the Contract. For Contract values not including Harmonized Sales Tax greater than \$500,000 the Bonds must be provided using Form 31 and Form 32 under Section 85.1 of the Construction Act, Ontario.
- .5 The Bonds shall be in the form set out in the Tender Documents or in such other form as may be acceptable to the CITY.
- .6 The CITY may consider alternate forms of security in lieu of the Bonds. The Tenderer shall make known any alternative form of security it wishes the CITY to consider and obtain the CITY's approval prior to submitting a Tender.
- .7 The Successful Tenderer shall provide all required Bonds to the CITY no later than 5 working days after receipt of the Letter of Intent from the CITY provided in accordance with Article 1.20. The Bonds must be received prior to the execution of the contract.

- .8 The Successful Tenderer shall supply all required Bonds before any Work is undertaken by the Successful Tenderer.
- .9 No payment shall be made by the CITY to the Successful Tenderer for any of the Work performed by the Successful Tenderer until the required Bonds have been provided.

1.14 INSURANCE

- .1 The Tender shall be accompanied by a Certificate of Insurance, certifying that the insurance as required by the Contract, is in place or, if the required insurance is not in place, by a Letter of Insurability or Undertaking of Insurance in standard form from the Tenderer's Insurance Broker certifying that the required insurance will be issued to the Tenderer if the Tenderer is the Successful Tenderer.
- .2 The Successful Tenderer shall be required to secure and maintain at its own expense the insurance provided for in the Contract.
- .3 The Successful Tenderer shall provide all required insurance to the CITY no later than 5 working days after receipt of a Letter of Intent from the CITY provided in accordance with Article 1.20.

1.15 RELEVANT EXPERIENCE & PROJECT TEAM

- .1 The Tender shall include a brief written summary of the Contractor's experience with similar construction projects. The summary shall highlight experience with multi-site projects and implementation of traffic management strategies.
- .2 The Tender shall include resumes highlighting relevant experience of key personnel proposed for the Work, including but not limited to the Project Manager, Project Coordinator, and Site Superintendent

1.16 TRAFFIC MANAGEMENT STRATEGY

- .1 The Tender shall include a brief written description of the Contractor's proposed traffic management approach.
- .2 The submission shall, at a minimum, address:
 - a. overall strategy for minimizing disruption to traffic and public access;
 - b. approach to staging of lane closures and coordination across multiple bridge sites;
 - c. consideration of peak periods, including weekends and high-traffic seasons;
 - d. approach to maintaining safe and efficient traffic flow during construction.
- .3 Detailed traffic control plans are not required at the time of Tender.

1.17 WORK SCHEDULE

- .1 The Tender shall be accompanied by a detailed Work Schedule in the form of a Gantt Chart.
- .2 The Work Schedule shall, at a minimum, include:
 - a. proposed commencement and completion dates for each bridge structure;
 - b. sequencing and coordination of work across all bridges included in the Contract;

- c. identification and duration of all lane closures and traffic restrictions, in accordance with applicable traffic control requirements;
- d. phasing and timing of all subcontracted work;
- e. identification of major milestones; and
- f. identification of long lead items
- g. any other activities necessary to clearly demonstrate the Contractor's plan to complete the Work within the Contract Time.

1.18 COMMENCEMENT AND COMPLETION OF THE WORK

- .3 The Successful Tenderer shall commence the Work 10 Working Days following contract execution and shall achieve substantial completion of the Work as defined in the contract by **November 20, 2026**.

1.19 SITE CONDITIONS

- .1 The Tenderer is responsible for inspecting the site(s) of the Work and for making whatever inquiries or arrangements necessary for it to become fully informed of the nature of the site(s) of the Work, including the soil structure and topography of the site(s), and of the Work to be performed and all matters which may in any way affect the Work. Without limiting the foregoing, by the submission of its Tender, the Tenderer acknowledges that it has investigated and satisfied itself as to:
 - a. the nature of the Work;
 - b. the location and all conditions relating to the location of the Work including, but not limited to, accessibility, general character, surface and sub-surface conditions, soil structure, utilities, road, uncertainties of seasonal weather and all other physical, topographical, geological and geographic conditions;
 - c. the general character, conditions, laws and restrictions applicable to the Work that might affect the performance of the Work;
 - d. all environmental risks, conditions, laws and restrictions applicable to the Work that might affect the Work; and
 - e. the magnitude of the work required to execute and complete the Work.
- .2 The Tenderer is fully responsible for obtaining all information required for the preparation of its Tender and for the execution of the Work. The CITY is not responsible for undertaking any investigations to assist the Tenderer. Any information, plans, drawings, shop drawings or existing equipment or facilities, photos of the original construction, reports or other documents which are not included or referred to in the Tender Documents (the "Non-Tender Information"), form no part of this Tender. The CITY and the CITY's Consultants assume no responsibility of any kind whatsoever arising from or relating to its failure to include or refer to such Non-Tender Information. Tenderers who obtain or rely upon such Non-Tender Information or other documents, do so entirely at their own risk.
- .3 The Tenderer's obligation to become familiar with the information described in Article 1.14.1 is not lessened or discharged by reason of any technical reports, including soils reports or data, test hole drilling reports or other soils information, made available or supplied in conjunction with the tendering process. Any technical reports so provided are for information only and neither the CITY nor the CITY's Consultants accept or assume any responsibility for the contents or accuracy of such technical reports and the Tenderer

agrees that the CITY, the CITY's Consultants and their representatives shall not be liable in any way to the Tenderer in respect of such technical reports. The Tenderer further agrees that it shall not rely upon any oral information provided to it by the CITY, the CITY's Consultants or their representatives.

- .4 Compensation will not be made for failure to make proper site investigations or to fully understand the nature of the work.

1.20 PRIME COST AND CONTINGENCY SUMS

- .1 The Tenderer shall include in its Tender Sum any prime cost sums or contingency sums. The Harmonized Sales Tax shall be shown as a separate amount.

1.21 PERMITS AND INSPECTIONS

- .1 The Tenderer shall include in its Tender Sum the cost of permits and inspections required by any governmental or other authority having jurisdiction or as required to fully perform the Work in accordance with the Contract.

1.22 SUCCESSFUL TENDERER

- .1 Award of Contract by the CITY occurs once the Tenderer receives a Letter of Intent executed by Greg Breen, Director of Infrastructure & Operations of the CITY.
- .2 Following the receipt of the Letter of Intent, the Successful Tenderer shall provide the Performance Bond and Labour and Material Payment Bond within the time required in Article 1.13.7. The Successful Tenderer shall also provide a Certificate of Insurance unless previously provided.
 - a. Upon the Successful Tenderer complying with the requirements of both Articles 1.22.2 and 1.22.4, the certified cheque or Bid Bond or irrevocable letter of credit, as the case may be, shall be returned to the Successful Tenderer.
 - b. If the Successful Tenderer fails to comply with either or both of the requirements of Articles 1.22.2 and 1.22.4, the certified cheque or Bid Bond or irrevocable letter of credit, as the case may be, shall be forfeited to the CITY as compensation for damages the CITY may suffer.
- .3 The forfeiture of a Successful Tenderer's certified cheque or Bid Bond or irrevocable letter of credit shall not be construed as a waiver of any rights or remedies which the CITY may have against such Tenderer for loss or damages incurred or suffered in excess of the amount of such certified cheque or Bid Bond or irrevocable letter of credit.
- .4 Within 5 working days of receipt of the Contract from the CITY, the Successful Tenderer shall duly execute the Contract and return the Contract to the CITY.

1.23 TENDER EVALUATION CRITERIA

- .1 Each Tender will be evaluated with a cost per point methodology on the basis of the criteria listed below and the CITY will have the sole and unfettered discretion to award up to the maximum number of points for each criterion as listed below. By submitting a Tender, the Tenderer acknowledges and agrees that the CITY has, and it is hereby entitled to exercise, the sole and unfettered discretion to award the points for the evaluation of the noted criteria.
- .2 By submitting its Tender, each Tenderer acknowledges and agrees that it waives any right to contest in any legal proceedings, the decision of the CITY to award points in respect of the criteria noted below. The criteria for evaluation are as follows:

- .3 The Tender will be evaluated on lowest price.

Criteria	Weight	Description
Work Schedule & Sequencing	40	Evaluation of proposed schedule, including coordination of work across multiple bridges, critical path, and ability to complete within Contract Time.
Traffic Management & Public Impact	20	Approach to minimizing disruption to traffic, including lane closures, staging, and consideration of peak summer/tourism periods.
Safety	15	
Relevant Experience & Project Team	25	Experience with similar bridge rehabilitation projects, particularly those involving staged construction and live traffic. Includes key personnel.
Total	100	

- .4 The CITY's selection of the successful Tenderer be based on which Tenderer has provided a Bid on terms which the CITY determines, in its sole and unfettered discretion, to be most beneficial or most advantageous to the CITY based on any criteria that may be employed by the CITY from time to time. The lowest or any Bid will not necessarily be accepted. After the selection of a Tenderer, the CITY has, in its sole and unfettered discretion, the right to negotiate with that Tenderer and, as part of that negotiation, to negotiate changes, amendments, or modifications to the Bid as submitted, without offering other Tenderers the opportunity to amend their Bids. The CITY shall incur no liability to any Tenderer as a result of these discussions, negotiations, or modifications. By submitting its Bid, each Tenderer waives its right to contest in any action, application, case or legal proceeding (in any court) the decision of the CITY to conduct any negotiation or the decision by the CITY of which Tenderer has submitted the most advantageous Bid. Both the CITY and the Tenderer expressly agree and acknowledge that all statements made by either side in the course of any negotiation are without prejudice and strictly confidential.
- .5 The CITY reserves the right to accept a Bid other than the lowest Bid without stating reasons.

1.24 WORKERS' COMPENSATION

- .1 Each Tenderer is to submit with its Tender, a letter of account from the Workplace Safety and Insurance Board – Ontario. This letter is to be current and must be dated no earlier than 21 calendar days prior to the Tender Closing. If the Contractor is not located in Ontario, the Contractor shall provide proof of good standing with the Workplace Safety and Insurance Board in their home province.
- .2 The Tenderers who do not have an account with the Workplace Safety and Insurance Board – Ontario shall provide with their Tender evidence of a subcontractor or other company that will carry such coverage on their behalf.
- .3 If the Tenderer is performing work in any exempt industry within the meaning of the Workplace Safety and Insurance Act (the "WSIB Act") and does not carry coverage, the Tenderer acknowledges that:
- a. The CITY is subject to a deeming order under s. 14(2) of the WSIB Act (the "Deeming Order"); and

- b. The Deeming Order states that all of the Tenderer's employees, directors, proprietors, partners or employees are deemed to be CITY employees for the purposes of the WSIB Act while performing work for the CITY; and
 - c. The effect of the Deeming Order is that the Tenderer's employees, directors, proprietors and partners who are injured while performing work for the CITY under the Contract, have no right to sue anyone and are limited to a claim under the WSIB Act.
- .4 The Tenderer shall communicate the existence and effect of the Deeming Order to all of its employees, directors, proprietors, partners or employees.
- .5 The CITY may reject any Tender which fails to comply with the provisions set out in Article 1.24.

1.25 REGISTRATION

- .1 Prior to commencing the Work, the Successful Tenderer shall obtain all authorizations required by the laws of the Province of Ontario and of the Country of Canada enabling it to carry on business to complete the Work required under the Contract. Failure to be properly authorized shall entitle the CITY to forthwith terminate the Contract without compensation.

1.26 TENDERS EXCEEDING BUDGET

- .1 In addition to the rights contained within Article 1.26 herein, if the Tender Sum of every Tenderer exceeds the amount the CITY has budgeted for the Work, the CITY may reject all Tenders or attempt to negotiate a lower price with the Tenderer who, in the sole and unfettered discretion of the CITY, has submitted the most advantageous Tender.
- .2 Each Tenderer acknowledges and agrees that the CITY has the sole and unfettered discretion to employ any criteria in order to determine the Tender most advantageous to the CITY, that the CITY has no obligation to neither disclose such criteria nor employ the criteria listed outlined in Article 1.23 Tender Evaluation Criteria.
- .3 By submitting its Tender, each Tenderer waives its right to contest in any action, application, case or legal proceeding in any court, the decision which the CITY may pursue under Article 1.26.1 and Article 1.26.2 herein.
- .4 If the Tender Sum of every Tenderer exceeds the amount budgeted for the Work and the CITY negotiates with the Tenderer who has submitted the Tender considered most advantageous to the CITY:
- a. All statements made by either side in the course of negotiation are without prejudice and confidential;
 - b. In particular, the CITY's attempt to negotiate with such Tenderer does not constitute a rejection of its Tender; and
 - c. The CITY will not attempt to obtain a lower price for the same work that the Tenderer originally bid on, but may attempt to obtain a lower price for an altered or reduced scope of work. In no event will the CITY be obliged to disclose the amount budgeted for the Work.

1.27 CERTIFICATE OF RECOGNITION ("C.O.R.") SAFETY PROGRAM REQUIREMENT

- .1 All Contractors must possess a valid Certificate of Recognition (COR) or recognized equivalent for an accredited workplace safety and health program in accordance with The Workplace Safety and Health Act as noted in Article 1.24.

- .2 The Contractor shall be the Prime Contractor and shall serve as and have the duties of the Prime Contractor in accordance with the Occupational Health and Safety Act (Ontario).
- .3 At the preconstruction meeting, provide the Consultant and Owner's representative with a copy of the Contractor's site-specific Health and Safety Plan and signed attestation.
- .4 Observe construction safety measures of National Building Code 2020 Part 8 Safety Measures at Construction and Demolition Sites, Ontario Occupational Health and Safety Act, Workplace Safety and Insurance Board Ontario, and the City of Kenora Safety requirements. In case of conflict or discrepancy, the more stringent requirements shall apply.

1.28 CANADIAN FREE TRADE AGREEMENT

- .1 The provisions of the Canadian Free Trade Agreement ("CFTA") apply to this Tender.

1.29 ACCEPTANCE OR REJECTION OF TENDERS

- .1 As it is the purpose of the CITY to obtain the Tender most suitable and most advantageous to the interests of the CITY, and notwithstanding anything else contained within the Tender Documents, the CITY reserves the right, in its sole and unfettered discretion, to reject or accept any Tender, including the right to reject all Tenders. Without limiting the generality of the foregoing, any Tender which
 - a. is incomplete, obscure, irregular or unrealistic;
 - b. is non-compliant in a trivial/immaterial or substantial/material manner, or conditional;
 - c. has erasures or corrections;
 - d. omits a price on any one or more items in the Tender;
 - e. fails to complete the information required in the Tender;
 - f. is accompanied by an insufficient certified cheque, irrevocable letter of credit or by a Bid Bond in an unsatisfactory form, may at the CITY's sole and unfettered discretion be rejected or accepted. Further, a Tender may be rejected or accepted on the basis of the CITY's unfettered assessment of its best interest, which includes the CITY's unfettered assessment as to a Tenderer's past work performance for the CITY or for anyone else or as to a Tenderer's financial capabilities, completion schedule, or ability to perform the Work, or the CITY's desire to reduce the number of different contractors on the location of the Work at any given time. The CITY reserves the right to negotiate after Tender Closing time with the Tenderer that the CITY deems has provided the most advantageous Tender; in no event will the CITY be required to offer any modified terms to any other Tenderer prior to entering into a Contract with the successful Tenderer and the CITY shall incur no liability to any other Tenderers as a result of such negotiation or modification.

1.30 LAW AND FORUM OF TENDER

- .1 The law to be applied in respect of the Tender Documents and the Contract shall be the law of the Province of Ontario and all civil actions commenced in relation to the Tender Documents or Contract shall be adjudicated by the Courts of the Province of Ontario and by submitting Tenders, Tenderers are taken to have agreed to attorn to the jurisdiction of the Courts of the said Province.

1.31 ACCEPTANCE PERIOD

- .1 The Tender shall be irrevocable and open for acceptance by the Consultant for the period of time contained in the Invitation to Tender, namely, sixty (60) days following the end of the day of the Tender Closing. The time and date of the Tender Closing is as defined in the Invitation to Tender.

1.32 DRAWING LIST

DWG NO.	TITLE
---------	-------

OSIM Bridge Maintenance Repairs

G-001	Title Page & Drawing Index
G-002	General Notes, Abbreviations, & Standard Repair Details
S-101	Bay Street Overpass – Existing Conditions & Repair Details
S-102	CPR Pedestrian Bridge – General Arrangement
S-103	CPR Pedestrian Bridge – Existing Stair Framing Plans & Repair Details
S-104	Darlington Bay Bridge – Existing Conditions & Repair Details
S-105	Eighth Avenue Bridge – Existing Conditions & Repair Details – Sheet 1 of 2
S-106	Eighth Avenue Bridge – Existing Conditions & Repair Details – Sheet 2 of 2
S-107	First Avenue Bridge – Existing Conditions & Repair Details – Sheet 1 of 2
S-108	First Avenue Bridge – Existing Conditions & Repair Details – Sheet 2 of 2
S-109	Matheson Street Bridge – Existing Conditions & Repair Details – Sheet 1 of 2
S-110	Matheson Street Bridge – Existing Conditions & Repair Details – Sheet 2 of 2
S-111	Parson Street Bridge – Existing Conditions & Repair Details
S-112	Seventh Avenue Bridge – Existing Conditions & Repair Details
S-113	Waste Transfer Station – Elevations & Section
S-114	Waste Transfer Station – Sections & Details
S-115	Winnipeg River East Bridge – Existing Conditions & Repair Details
S-116	Winnipeg River West Bridge – Existing Conditions & Repair Details – Sheet 1 of 2
S-117	Winnipeg River West Bridge – Existing Conditions & Repair Details – Sheet 2 of 2
S-118	Portage Bay Walkway Bridge – Existing Conditions & Repair Details

END OF SECTION

Lake of the Woods
KENORA



PART 2: TENDER FORMS

**CITY OF KENORA
Bride Maintenance Repairs
ITT# 312-003-26**

SECTION 1 TENDER FORMS

TENDER NUMBER: 312-003-26

TENDER TITLE: BRIDGE MAINTENANCE REPAIRS

WE, _____
(COMPANY)

OF _____
(BUSINESS ADDRESS)

HAVING EXAMINED THE TENDER DOCUMENTS AS ISSUED BY: THE CITY OF KENORA (THE "CITY"), AND HAVING VISITED THE SITE(S) OF WHERE THE WORK IS REQUIRED TO BE UNDERTAKEN; HEREBY OFFER TO ENTER INTO A CONTRACT TO PERFORM THE WORK REQUIRED BY THE TENDER DOCUMENTS FOR THE TENDER SUM AS FOLLOWS:

1. Bridge Maintenance Repairs \$ _____

2.

(Tender Sum written in words)

3. Ontario Harmonized Sales Tax (HST = 13%) \$ _____

4. Total Tender Sum (Summation of Items 1 & 3 above) \$ _____

5.

(Total including HST written in words)

IN CANADIAN FUNDS, WHICH PRICE INCLUDES ANY SPECIFIED CASH AND CONTINGENCY ALLOWANCES AND THE APPLICABLE TAXES IN FORCE AT THIS DATE AND EXCEPT AS MAY BE OTHERWISE PROVIDED IN THE TENDER DOCUMENTS.



The Unit Price Schedule shall be completed in accordance with the Tender Documents, any errors will be corrected as identified in Article 3.0.

SCHEDULE OF PRICES

Bridge Maintenance Repairs

ITEM NO.	DESCRIPTION	UNIT	APPROX. QTY.	UNIT PRICE	AMOUNT
1	Mobilization, Demobilization, and Site Work	L.S.	1	\$	\$
2	Signs, Traffic Control, and Minimizing Traffic Obstructions	L.S.	1	\$	\$
3	Construction Layout	L.S.	1	\$	\$
4	Concrete Repairs	sq.m	93	\$	\$
5	Asphalt Repairs	sq.m	360	\$	\$
6	Timber Plank Replacement	L.S.	1	\$	\$
7	Clear Vegetation from Embankments	L.S.	1	\$	\$
8	Joint Seal Replacements	l.m.	29	\$	\$
9	Replace Signs	each	3	\$	\$
10	Paving Stone Sidewalk Repair	sq.m	5	\$	\$
11	Cleaning Corroded Steel	L.S.	1	\$	\$
12	Wall Pack Light Replacement	L.S.	1	\$	\$
13	Waste Transfer Station Edge Armouring	l.m.	16	\$	\$
14	Miscellaneous Maintenance	L.S.	1	\$	\$
15	Utility Conduit Repair	L.S.	1	\$	\$
16	Glued Laminated Timber Repairs	L.S.	1	\$	\$

SUB-TOTAL BID (CAD) \$

HST (CAD) \$

TOTAL BID PRICE BRIDGE MAINTENANCE REPAIRS (CAD) \$



**Refer to the technical specifications and drawings for further clarification as these items require follow-up inspection prior to repair development and subsequent pricing.*

SECTION 2 APPENDICES TO TENDER FORMS

- .1 The information required by the Instructions to Tenderers is provided in the attached Appendices and forms an integral part of this Tender.

SUPPLEMENTS TO TENDER FORM

In order to aid the Owner in evaluating the tender, tenderers are to submit their teams resumes as requested.



SUPPLEMENTS TO TENDER FORM

FORM C: Alternatives

List any material, equipment, or construction method proposed as an alternate to the material specified, together with all costs and supporting information required in accordance with the "INSTRUCTIONS TO TENDERERS". Attach supporting description and technical data to the Tender. Use separate sheet if space below is not sufficient.

NOTE: Indicate "N/A" or "none" if no alternatives are submitted at the time of tendering.

Name of Item to be Substituted	Specification Reference	Alternative	Addition to Total Tender Price	Deduction from Total Tender Price

NOTE: Failure of the tenderer to complete FORM C may be grounds for rejecting the Tender.

Signature of Witness

Signature of Tenderer (Seal)

Seal



DECLARATIONS:

- .1 We hereby acknowledge and declare that:
 - a. we agree to perform the Work in compliance with the required completion schedule stated in the Contract;
 - b. no person, firm or corporation other than the undersigned has any interest in this Tender or in the proposed Contract for which this Tender is made;
 - c. the Tender Security is attached to this Tender. We specifically acknowledge and agree that the Tender Security may be forfeited to the City pursuant to the terms set forth in the Instructions to Tenderers;
 - d. we hereby acknowledge and confirm that the City has the right to accept any tender or to reject any or all tenders in accordance with the Instructions to Tenderers;
 - e. this Tender is open to acceptance for a period of sixty (60) days from the date of Tender Closing.

Signatures:

Signed, sealed and submitted for and on behalf of:

Company:

(Name)

(Street Address or Postal Box Number)

(City, Province & Postal Code)

(Apply SEAL above)

Signature:

Name & Title:

(Please Print or Type)

Witness:

Dated at _____ this _____ day of _____, 20____



Lake of the Woods
KENORA



PART 3: TECHNICAL SPECIFICATIONS

**CITY OF KENORA
Bride Maintenance Repairs
ITT# 312-003-26**

SECTION 1 GENERAL

1.1 WORK INCLUDED

- .1 The Work, unless specifically stated otherwise, shall include the furnishing of all material, product, plant, labor, and transportation necessary to complete the Work. The intent is that the Contractor provides a complete job.
- .2 The Work shall not be deemed complete until all components are placed in operation by the Contractor, and are operating to the satisfaction of the Contract Administrator.
- .3 Any minor items of the Work not called for in the Specifications or shown on the Drawings but clearly required to meet the intent of design and normally provided for the proper operation of the Work shall be provided as if specifically called for in the Contract Documents.
- .4 The use of the word "provide" means "supply and install"; or "supply labor and materials for the installation of". It does not mean supply only.
- .5 Where there is an ambiguity between a Standard and any term of these Contract Documents, the Contract Administrator shall, in the first instance, give an interpretation of the intent of the Contract.

1.2 PERMITS, LICENSES, REGULATIONS, AND ACTS

- .1 The Contractor shall be responsible for obtaining and paying for any and all permits or licenses as may be required for any portion of this contract. The Contractor shall be responsible for meeting the requirements of all permits and licenses granted, as well as compliance with all applicable Acts and Regulations.
- .2 The Contractor shall ensure compliance on their part and on the part of all of Subcontractors with Fisheries and Oceans Canada, and the Canadian Navigable Waters Act.

1.3 ENVIRONMENTAL PROTECTION

- .1 All Contractor activities must conform to the applicable environmental protection laws and regulations. Appendix B provides DFO's Interim Code of Practice: Bridge Repair and Maintenance to avoid causing harm to fish and provides general advice to comply with these Acts. This document shall only be considered as advice, and it shall be the Contractor's responsibility to adhere to all required laws, acts, and regulations.
- .2 Applicable codes and standards related to the Environmental Protections, particularly with regards to Ontario Provincial Standards.
- .3 Any work adjacent to waterways or which may result in sediment or debris entering the waterway will require the Contractor to implement control measures to contain the debris or control the sediment. Such measures shall be installed prior to the commencement of construction.
- .4 Protect trees and plants on site and adjacent properties with removal only as approved by the Contract Administrator.



1.4 CONSTRUCTION SCHEDULE

- .1 Upon award of the Contract, the Contractor shall provide the Consultant with a detailed work schedule at least twenty (20) Working Days prior to the commencement of any Work on site. The Construction Schedule shall be in critical path method format showing all the principal phases of the WORK. No Progress Payment Claim shall be certified until an acceptable Construction Schedule has been received and approved by the Consultant.
- .2 The Construction Schedule, as stated above, will be held as a baseline. The Construction Schedule shall be updated every two weeks against actual progress of the work by the Contractor. The updated Construction Schedules do not relieve the Contractor from the obligation of the Completion Date.
- .3 If, in the opinion of the Consultant, the Construction Schedule is inadequate as a control tool or if it does not show the work being fully completed by the Contract Completion Date, the Consultant may reject it, and the Contractor shall provide a Construction Schedule and work program that is acceptable to the Consultant.
- .4 The Contractor shall require written permission from the City of Kenora for any work to be performed between the hours of 21:00 and 07:00. Such work shall conform to all applicable laws and by-laws.
- .5 The Contractor's schedule shall identify anticipated periods of lane restrictions during the Work.

1.5 PROJECT MEETINGS

1.5.1 PRE-CONSTRUCTION START UP MEETING

- .1 A preconstruction meeting will be arranged by the Consultant after the award of Contract.
- .2 The Consultant will give five (5) Working Days advance notice of meeting dates, times and locations to all parties.
- .3 The Contractor shall have in attendance the Superintendent, the Contractor's Project Manager and representatives of the subcontractors if requested by the Consultant.
- .4 The Owner will have a representative in attendance.
- .5 The Consultant's representative will chair the meeting and record and distribute the minutes
- .6 The meeting will be held virtually via Microsoft Teams.
- .7 The agenda for the Preconstruction Meeting shall include, but is not limited to, the following:
 - a. Confirm representatives of the Owner, Contractor, Subcontractors and Resident Consultant personnel on the worksite.
 - b. Establish project protocols for communication, reporting, inspection, etc.
 - c. Owner-supplied products
 - d. Contract modification procedures



- e. Payment procedures
- f. Construction progress meetings
- g. Construction progress schedule
- h. Submittals schedule and procedures
- i. Quality requirements, including testing and inspection procedures
- j. Contractor's mobilization
- k. Clear up any ambiguities or questions of interpretation of the Work known at that time.
- l. Occupational Health and Safety relationships and responsibilities.
- m. Review and discuss Contractor's site safety plan.
- n. Cleaning and waste management
- o. Close out procedures and submittals
- p. Discuss other responsibilities of the Owner, the Contractor, and the Consultant

1.5.2 CONSTRUCTION PROGRESS MEETING

- .1 Progress meetings will be held on a bi-weekly basis or more frequently if requested by the Consultant.
- .2 The Consultant will prepare meeting agendas, chair meetings, record and distribute the minutes
- .3 The Consultant will record in the meeting minutes significant decisions and identify action items and action dates by attendees.
- .4 The Consultant will distribute copies of minutes within three (3) Working Days after each meeting to meeting attendees and any affected parties who may not be in attendance
- .5 Contractor to ensure that Subcontractors attend as and when appropriate to the progress of the Work
- .6 The Contractor shall submit a Submittal Tracking Log prior to each progress meeting. The log shall identify all submittals, including but not limited to shop drawings, inspection reports, and Requests for Information (RFIs), and shall include the date of submission, current status, and identification of any submittals that may impact the Work Schedule, including anticipated dates of impact.
- .7 Agenda for each meeting shall include the following, as a minimum:
 - a. Approval of minutes of previous meeting.
 - b. Work progress since previous meeting.
 - c. Field observations, including any problems, difficulties, or concerns.
 - d. Construction progress schedule.
 - e. Traffic Impacts



- f. Submittals schedule.
- g. Proposed changes in the Work.
- h. Requests for information.
- i. Upcoming inspections and testing activities, including those required for quality control
- j. Site safety issues.
- k. Other business.

1.6 COMMUNICATION PLAN

- .1 The City of Kenora shall be included in all project communications and meetings that may impact scope, schedule, cost, traffic management, or public operations.
- .2 The Contractor shall ensure that the Owner is copied on all written project correspondence, including but not limited to:
 - a. Requests for Information (RFIs)
 - b. Site Instructions (SIs)
 - c. Change Notices (CCNs), Change Directives (CDs), and Change Orders (COs)
 - d. Inspection reports and deficiency lists
 - e. Schedule submissions and updates
 - f. Traffic control plans and updates
 - g. Notices of delay or disruption
- .3 The Contractor shall provide written notice to the Contract Administrator and Owner a minimum of fifteen (15) Working Days in advance of any planned work that will impact traffic flow, lane closures, or public access. Such notice shall include the proposed timing, duration, and extent of the impact. The Contractor shall not implement any traffic restrictions or changes to public access without prior review and approval by the Contract Administrator and coordination with the Owner.
- .4 All public-facing communications, including notices related to traffic disruptions or closures, shall be coordinated with and approved by the Owner prior to issuance.

1.7 FIELD ENGINEERING

- .1 The Contractor shall be responsible for setting all temporary benchmarks required to complete the Work.
- .2 Throughout the course of the work, the Contractor shall confirm the accuracy of their temporary benchmarks. Claims will not be entertained for work installed incorrectly due to survey error.
- .3 The Contractor shall be responsible for the true and proper layout of the work and for the correctness of the location, levels, dimensions, and alignment of all aspects of the work.



The Contractor shall provide all required instruments and competent personnel for performing all layouts.

- .4 Should any error appear or arise in location, levels, dimensions, and/or alignments during the WORK, the Contractor shall promptly rectify such errors to the satisfaction of the Consultant at their own expense.
- .5 The Consultant shall be notified at least two (2) Working Days prior to any Work being commenced in order to have the option to check and review all elevations and layouts at the Consultant's discretion.

1.8 TEMPORARY FACILITIES AND CONTROLS

- .1 The Owner will allow the Contractor to set a worksite within the right of way. The limits of the worksite have not been noted on the Drawings.
- .2 The Contractor shall have agreements in place with landowners for any work requiring access onto private property. Such agreements shall be the responsibility of the Contractor. Copies of these agreements shall be provided to the Consultant. It shall be the responsibility of the Contractor to confirm the extents and locations of all private property lines adjacent to the proposed works.
- .3 The Contractor shall have exclusive use and control of the worksite, provided that the Contractor shall permit access to the Owner, the Consultant, and other contractors for purposes of inspections, reviews, tests and carrying out work related to the work.
- .4 Contractor's use of the worksite for storage is limited to the areas within the right of way.
- .5 During the Contractor's use of a particular area of the worksite to execute the work, the Contractor shall be responsible primarily for security and for ensuring compliance with Health and Safety Regulations.
- .6 The Contractor shall be responsible for access to the worksite by means of temporary roads, tote roads, or agreements with the appropriate authorities or landowners to use existing means of access.
- .7 The Contractor shall return the areas of the worksite used for construction access, laydown, storage, etc. to the condition before the construction commenced or as agreed upon in the applicable landowner agreement.
- .8 The Contractor shall provide and pay all costs for natural gas, gasoline and other fuels, water, electricity and lighting, telephone, heating and ventilating, sanitary facilities, fire protection, temporary plants, temporary enclosures, false work, temporary construction supports, temporary excavation, access roads, and tree protection as required to complete the Work.
- .9 The Contractor shall be responsible for location, protection, temporary support, removal, or replacement of existing utilities and structures, or for repair of any damage which may occur during construction including all required designs.
- .10 Existing utilities that exist near or are attached to the bridges shall be safely supported and protected by the Contractor through the duration of the work and to the satisfaction of the utility Owner(s) and the Consultant.
- .11 The Contractor shall pay all costs and be responsible for establishing locations and state of use of all existing utilities that may affect the Work. The Contractor shall make



-
- satisfactory arrangements with the utilities companies involved for the location, protection, and inspection of existing utilities.
- .12 The Contractor shall pay all the costs involved in protection of utilities, inspection of utilities, and all costs due to delays because of existing utilities and structures.
 - .13 The Contractor shall provide for the uninterrupted flow of all water courses, sewers, and drains encountered during the WORK.
 - .14 Access shall be maintained to all existing structures such as valves, hydrants, meter chambers and control structures at all times during construction.
 - .15 If interruption of service provided by an existing utility is necessary, the planned shut down shall be approved by the Owner of the utilities.
 - .16 Unless otherwise specified, the Contractor shall make arrangements for relocation of existing utilities that the Consultant requests to be relocated; and the actual relocation shall be constructed by the Owner of the utility. The Contractor will be reimbursed the invoiced cost of the relocation. No extra payment is permitted for delays, or standby time.
 - .17 Controls:
 - a. Perform the Work in conformity with all municipal by laws with respect to noise, hours of work, night work, and holiday work.
 - b. Perform the Work in a manner that will not produce an objectionable amount of dust. Dust control measures shall be paid for by the Contractor.
 - c. Perform the Work in conformance with the applicable sections of the Provincial Regulations with respect to air and water pollution control requirements.
 - .18 Disposal of Wastes:
 - a. Burying of rubbish and waste on the worksite is not permitted.
 - b. Disposal of waste or volatile materials into waterways, storm or sanitary sewers is not permitted.
 - c. Pumping or draining water containing silt in suspension into waterways, sewers, or drainage systems is prohibited.
 - d. Abide by requirements of Statute, Bylaw, and Regulations respecting disposal of wastes.
 - e. Obtain required Permits for waste disposal.
 - .19 Do not operate construction equipment in waterways, nor remove borrow material nor dump fill material into waterways, except as approved and permitted by the appropriate authorities. The regulatory approvals must be strictly followed when working adjacent to the waterway.
 - .20 The Contractor shall maintain haul routes. They shall be kept open to traffic and shall be clean at all times. Any damage done to the haul routes by the Contractor shall be repaired as approved by the Consultant and all costs shall be borne by the Contractor.
 - .21 Obtain permits as required to use public roads or streets for haul routes.



- .22 Special care shall be taken to avoid damage to all existing adjacent structures or properties during the course of the work. Any damage caused by the Contractor to the existing adjacent structures or properties shall be repaired at their own expense and to the satisfaction of the Consultant.

1.9 HEALTH AND SAFETY POLICY

- .1 The Contractor shall adhere to the City of Kenora Health and Safety Policy and shall be responsible for all site safety aspects of the Work.
- .2 During construction, health and safety meetings shall be conducted as required by the Occupational Health and Safety Act (OHSA).

1.10 MEASUREMENT FOR PAYMENT

- .1 Notify the Consultant sufficiently in advance of operations to allow required measurements for payment. Unless otherwise specified, measurements shall be taken in accordance with the General and Supplementary Conditions.

1.11 DOCUMENTS REQUIRED ON SITE

- .1 Maintain at the worksite at least one copy of each of the following:
- a. Contract drawings
 - b. Specifications
 - c. Addenda
 - d. Change Orders, Field Orders, Notices
 - e. Reviewed Shop Drawings
 - f. Modifications to the Contract
 - g. Field Test Reports
 - h. Construction Schedule
 - i. Manufacturer's Installation and Application Instructions
 - j. Occupational Health and Safety Regulations and Workers' Compensation Board Regulations
 - k. Environmental Applications, Authorizations or Assessments
 - l. Have readily available any referenced or specified Standards.

1.12 MATERIAL AND INSTALLATION

- .1 Material and product supplied and installed shall be new and shall conform to these Specifications and to the specified standards.
- .2 Workmanship shall be the best quality, executed by workers experienced, and skilled in their respective trades.



- .3 Ensure full cooperation among all trades and coordination of the WORK with continuous supervision.
- .4 Use product for which replacement parts and service are readily available.
- .5 Unless otherwise specified, comply with the manufacturer's / supplier's instructions for material or product and installation methods.
- .6 Provide metal fastenings and accessories in the same texture, colour, and finish as the base metal in which they occur. Prevent electrolytic action between dissimilar metals. Use non-corrosive fasteners, anchors, and spacers for securing exterior Work, or Work that may be located in a corrosive atmosphere.
- .7 Space anchors within limits of load bearing or shear capacity and ensure that they provide positive permanent anchorage. Space fasteners evenly and lay out neatly.

1.13 DELIVERY AND STORAGE OF MATERIALS

- .1 Deliver, store, and maintain packaged material and product with manufacturer's seals and labels intact.
- .2 Prevent damage and soiling of material and product and store in accordance with instructions of the manufacturer / supplier.
- .3 Provide suitable areas or buildings where storage is weatherproof, if the manufacturer / supplier recommends dry areas.
- .4 Comply with Workplace Hazardous Materials Information Systems requirements.
- .5 Material that is improperly stored resulting in damage due to the Contractor's negligence shall be replaced at the Contractor's expense.

1.14 QUALITY CONTROL

1.14.1 CONTRACTORS RESPONSIBILITIES

- .1 The Contractor shall be totally responsible for the quality of material and product which the Contractor provides and for the work.
- .2 The Contractor shall be responsible for quality control and shall perform such inspections and tests as are necessary to ensure that the Work conforms to the requirements of the Contract Documents.
- .3 During the progress of the Work, a sufficient number of tests shall be performed by the Contractor to determine that material, product, and installation meet the specified requirements.
- .4 Minimum requirements regarding quality control are specified in various sections of the Specifications, however, the Contractor shall perform as many inspections and tests as are necessary to ensure that the work conforms to the requirements of the Contract Documents.
- .5 Testing shall be in accordance with pertinent codes and regulations, and with selected standards of the American Society for Testing and Materials (ASTM) and Canadian Standards Association (CSA).



1.14.2 INDEPENDENT TESTING

- .1 The Contractor shall retain the services of an independent testing agency under supervision of a registered Professional Engineer, and pay the cost of testing services for quality control including, but not limited to, the following:
 - a. Sieve analysis of sands and aggregates to be supplied to the work.
 - b. Aggregates and mix designs for asphaltic concrete.
 - c. Aggregates and mix designs for Portland Cement concrete.
 - d. Standard Proctor Density curves for all granular materials.
 - e. Compaction control tests for all granular and asphaltic materials.
 - f. Slump, air content, and strength tests for concrete.
 - g. Any product testing that is required and is specified under various sections of the Specifications.

1.14.3 INSPECTION, HOLD POINTS & REPORTING

- .1 The Contractor shall provide reasonable advance notice to the Consultant of all inspection and testing activities to allow for observation of the Work.
- .2 The Contractor shall not proceed with or conceal any portion of the Work requiring inspection or testing until such inspection or testing has been completed and reviewed by the Consultant.
- .3 The Contractor shall promptly process and distribute all required copies of test reports and test information within two (2) Working Days of receipt. Any product that does not meet required specifications shall be replaced at the Contractor's expense. Performing such work is not cause of an extension of the Contract Time.

1.14.4 NON-CONFORMANCE

- .1 Any Work or material that does not conform to the Contract Documents shall be identified and reported to the Consultant immediately. The Contractor shall not proceed with dependent Work until the non-conformance has been addressed to the satisfaction of the Consultant.
- .2 When tests on product, material, or completed portions of the work carried out by the Contractor or the Contractor's testing agency or by the Owner's testing agency yield results not meeting the requirements of the Contract Documents, the Contractor, in addition to carrying out remedial Work or replacement of the Product or Material shall cover all costs for retesting of the remedied Work and the replacement Product and Material. Retesting shall be at the Contractor's expense.
- .3 If the Contractor fails or refuses to do remedial Work or replace unacceptable material or product, the Consultant may refuse to certify payment and the Owner may refuse to make payment, in addition to any other remedies the Owner may have.



1.15 SHOP DRAWINGS

- .1 The Contractor shall arrange for the preparation of clearly identified Shop Drawings and submit one (1) electronic PDF Shop Drawing to be reviewed by the Consultant.
- .2 Shop Drawings shall be coordinated with the Submittal Schedule and Submittal Tracking Log.
- .3 Shop Drawings shall be in accordance with the International System of Units (S.I.) metric units.
- .4 Prior to submission to the Consultant, the Contractor shall review all Shop Drawings. The Contractor's review of each Shop Drawing shall be indicated by stamp, with the date and signature of a responsible person.
- .5 The Contractor shall submit Shop Drawings to the Consultant for review a minimum of fifteen (15) Working Days in advance of the Work requiring the Shop Drawings. Submittals shall be made in an orderly sequence and in sufficient time to avoid delays to the Work.
- .6 At the time of submission, the Contractor shall notify the Consultant in writing of any deviations in the Shop Drawings from the requirements of the Contract Documents.
- .7 The Consultant's review shall be for conformity to the design concept and for general arrangement only and such review shall not relieve the Contractor of responsibility for errors or omissions in the Shop Drawings or of responsibility for meeting all requirements of the Contract Documents.
- .8 The Contractor shall make any changes to the Shop Drawings which the Consultant may require consistent with the Contract Documents and resubmit unless otherwise directed by the Consultant.
- .9 Where the Contractor is required, either by law, regulation or by the Contract to provide engineering design, they shall use the services of a Professional Engineer registered in the Province of Ontario and shall submit Shop Drawings bearing the Seal and Signature of that Registered Professional Engineer.

1.16 REQUESTS FOR INFORMATION

- .1 All Requests for Information (RFIs) shall be submitted by the Contractor to the Contract Administrator.
- .2 Each RFI shall be clearly identified and shall include, at a minimum:
 - a. Project name and contract number;
 - b. Reference to applicable drawing(s) and specification section(s);
 - c. A clear description of the question or issue;
 - d. The Contractor's proposed solution, where applicable;
 - e. Identification of any potential impact to scope, schedule or cost.
- .3 RFIs shall be submitted within two (2) Working Days of the Contractor becoming aware of the need for clarification. The Contractor shall not delay submission of RFIs where such delay may impact the Work.



-
- .4 The Contract Administrator will review RFIs and respond within a reasonable timeframe. The Contractor shall allow sufficient time in the Construction Schedule for RFI review and response.
 - .5 The Contractor shall maintain an up-to-date RFI log and include it as part of the Submittal Tracking Log submitted at each progress meeting.

1.17 CONTRACT CLOSE-OUT

- .1 Maintain the working area in a clean and orderly manner as the Work progresses, and upon completion of construction, remove all waste Materials, and all temporary facilities from the Worksite.
- .2 Haul surplus or salvage materials that are the property of the Owner to the Owner's storage site. Remove surplus or salvaged materials belonging to the Contractor from the worksite.
- .3 Clean haul routes and restore haul roads to their preconstruction condition.
- .4 Broom clean paved surfaces; rake clean other surfaces of ground.
- .5 The Contractor shall notify the Consultant when the Work is considered for Substantial Performance. The Contractor shall accompany the Consultant on the Substantial Performance walk-through.
- .6 The Contractor shall comply with the Consultant's instructions for correction of items of Work listed to be corrected in conformance with the Contract Documents.

1.18 WARRANTY INSPECTION

- .1 The Consultant shall arrange and conduct with the Owner and the Contractor a warranty inspection at the site prior to the expiration of the warranty period.

1.19 MEASUREMENT AND PAYMENT

- .1 Refer to Section 20 Measurement and Payment.

END OF SECTION



SECTION 2 MOBILIZATION, DEMOBILIZATION, AND SITE WORK

2.1 DESCRIPTION

- .1 This Specification shall cover the Mobilization, Demobilization, and Site Work required for the Work of this project. The Work to be done by the Contractor under this Specification shall include the furnishing of all superintendence, overhead, labour, materials, equipment, tools, supplies, and all things necessary for and incidental to the satisfactory performance and completion of all work as hereinafter specified.

2.2 SCOPE OF WORK

- .1 Mobilization, Demobilization, and Site Work shall include the Contractor's costs of mobilization at the beginning of the Work and the costs of demobilization at the end of the Work.
- .2 Included in Mobilization, Demobilization, and Site Work are such items as permits, moving personnel, bonding and insurance, lodging expenses, materials, and equipment to and from the site, setting up temporary facilities, temporary land use agreements, temporary utilities, and all site preparation for performing the Work.
- .3 All costs associated with site cleanup, general grading, and restoration to the original condition of the Site and any disturbed areas upon completion shall be included herein this pay item.
- .4 All regulatory body required costs (material, labour) shall be included herein this pay item.
- .5 The Contractor shall be responsible for obtaining all utility clearances and the costs associated with the clearances shall be included herein this pay item.
- .6 The Contractor shall be responsible for all rail flagger and rail access requirements for the construction of the works, as required, and the cost associated with, but not limited to, the flagging, coordination, and clearances shall be included herein this pay item.
- .7 The supply and placement of any and all erosion protection and silt fence barriers shall be considered a part of this pay item.
- .8 This pay item shall include final site clean-up, grading, seeding and revegetation, and placement of Erosion Control Blanket (ECB) required to restore the worksite to preconstruction condition.

2.3 MEASUREMENT AND PAYMENT

- .1 Refer to Section 20 Measurement and Payment.

END OF SECTION



SECTION 3 TRAFFIC CONTROL AND PEDESTRIAN ACCOMMODATION

3.1 DESCRIPTION

- .1 This Specification shall cover all operations relating to the provision of traffic control and pedestrian accommodation for single-lane, two-way traffic operation at the bridge locations.
- .2 The work to be done by the Contractor under this Specification shall include the furnishing of all superintendence, overhead, labour, materials, equipment, tools, supplies, and all things necessary for and incidental to the satisfactory performance and completion of all work as hereinafter specified.

3.2 SCOPE OF WORK

- .1 Traffic control and pedestrian accommodation shall include supply, installation, operation, relocation, maintenance, and removal of all traffic control devices, portable temporary traffic signals, pedestrian accommodation devices, as well as the provision of flag persons. The provision and implementation of traffic control shall be in accordance with the Ontario Traffic Manual (OTM) Book 7 except as otherwise specified herein and directed / approved by the Contract Administrator.
- .2 At least fifteen (15) Working Days prior to restricting traffic, notify the following:
 - a. Roadway Authority
 - b. Public Works Departments
 - c. Utilities Companies
 - d. Fire Department
 - e. Police Department
 - f. Ambulance
- .3 The Contractor shall prepare and submit a Traffic Control and Pedestrian Accommodation Plan to the Consultant for review and comment at least fifteen (15) Working days prior to proceeding with on-site traffic control and pedestrian accommodation. The Contractor shall coordinate the Work with the Consultant, and the Owner to reduce traffic and pedestrian problems.
- .4 The Contractor shall be responsible for all construction zone barriers, barricades, warning signs, detours, fences, flag persons, and all other devices required to protect the public. All applicable safety standards will be followed. Under no circumstances will hand painted lettering, diagrams, or symbols be permitted.
- .5 No lane restrictions, closures nor boat access restrictions shall be permitted on Fridays, Saturdays and Sundays.
- .6 No lane restrictions, closures nor boat access restrictions shall be permitted on public and statutory holidays. These holidays are noted below:
 - a. Victoria Day – Monday May 18, 2026 (no closures or restrictions from Friday May 15 to Monday May 18)



- b. Canada Day – Wednesday July 1, 2026
 - c. Civic Holiday – Monday August 3, 2026 (no closures or restrictions from Friday July 31 to Monday August 3, 2026)
 - d. Labour Day – Monday September 7, 2026 (no closures or restrictions from Friday September 4 to Monday September 7, 2026)
 - e. National Day for Truth and Reconciliation – Wednesday September 30, 2026
 - f. Thanksgiving – Monday October 12, 2026 (no closures or restrictions from Friday October 9 to Monday October 12, 2026)
 - g. Remembrance Day – Wednesday November 11, 2026
 - h. Christmas Day – Friday December 25, 2026 (no closures or restrictions from Friday December 25 to Monday December 28, 2026)
- .7 No lane closures shall be permitted on Lakeview Drive on Wednesdays.
- .8 The Contractor may submit proposals for full bridge closures; however, all such proposals are subject to the sole discretion and written approval of the City.
- .9 If required to complete the work, the Contractor shall design, supply, install, and remove temporary traffic signals at each end of the bridge(s) throughout the duration of construction, which will allow for one, two-way traffic lane to function to accommodate traffic in both directions.
- a. The Contractor shall be responsible for traffic signal timing design and shall make required adjustments in the field to properly accommodate the flow of traffic.

3.2.1 ALLOWABLE LANE RESTRICTIONS BY BRIDGE

- .1 For Bay Street Overpass:
- a. A minimum of one, two-way traffic lane must be maintained at all times. Traffic flow shall be managed with either traffic signals or through flag person operations.
- .2 For Darlington Bay Bridge:
- a. A minimum of one, two-way traffic lane must be maintained at all times. Traffic flow shall be managed with either traffic signals or through flag person operations.
- .3 For Eighth Avenue Bridge:
- a. A minimum of one, two-way traffic lane must be maintained at all times. Traffic flow shall be managed with either traffic signals or through flag person operations.
- .4 For First Avenue Bridge:
- a. A minimum of one, two-way traffic lane must be maintained at all times. Traffic flow shall be managed with either traffic signals or through flag person operations.
- .5 For Matheson Street Bridge:
- a. A minimum of one, two-way traffic lane must be maintained at all times. Traffic flow shall be managed with either traffic signals or through flag person operations.



- b. A minimum of one pedestrian sidewalk must be maintained at all times.
- .6 For Parson Street Bridge:
 - a. A minimum of one, two-way traffic lane must be maintained at all times. Traffic flow shall be managed with either traffic signals or through flag person operations.
- .7 For Seventh Avenue Bridge:
 - a. A minimum of one, two-way traffic lane must be maintained at all times. Traffic flow shall be managed with either traffic signals or through flag person operations.
 - b. Pedestrian accommodations to cross the bridge shall be provided throughout the duration of the WORK. Pedestrian accommodation shall consider the requirements needed to properly protect the public from the Construction activities, hazards, and traffic. The width of the pedestrian accommodation shall match the existing sidewalk and shall provide universal access
- .8 For Waste Transfer Station:
 - a. The Contractor shall coordinate with the City in terms of timing for repairs based on the City's operation schedule for the facility.
- .9 For Winnipeg River East Branch Bridge:
 - a. A minimum of one, two-way traffic lane must be maintained at all times. Traffic flow shall be managed with either traffic signals or through flag person operations.
 - b. Pedestrian accommodations to cross the bridge shall be provided throughout the duration of the WORK. Pedestrian accommodation shall consider the requirements needed to properly protect the public from the Construction activities, hazards, and traffic. The width of the pedestrian accommodation shall match the existing sidewalk and shall provide universal access.
- .10 For Winnipeg River West Branch Bridge:
 - a. A minimum of one, two-way traffic lane must be maintained at all times. Traffic flow shall be managed with either traffic signals or through flag person operations.
 - b. Pedestrian accommodations to cross the bridge shall be provided throughout the duration of the WORK. Pedestrian accommodation shall consider the requirements needed to properly protect the public from the Construction activities, hazards, and traffic. The width of the pedestrian accommodation shall match the existing sidewalk and shall provide universal access.

3.3 MATERIALS AND EQUIPMENT

- .1 The Contractor shall be responsible for the supply, safe storage, and handling of all materials and equipment set forth in this Specification.
- .2 All materials shall be handled and stored in a careful and workmanlike manner, to the satisfaction of the Consultant.
- .3 All traffic control devices (signage, channelization devices, barricades), portable temporary traffic signals, and flag persons shall be in accordance with the OTM Book 7, and as specified herein.



3.4 CONSTRUCTION METHODS

.1 General

- a. The Contractor shall supply and install traffic control devices and portable temporary traffic signals and have them ready for putting into operation before the work affecting vehicle and pedestrian traffic begins. The Contractor shall coordinate and undertake the installation and operation of all required traffic control devices, portable temporary traffic signals, and temporary concrete barriers. Traffic control signs shall be temporarily covered or laid down until such time as needed to be visible for the work affecting traffic.
- b. Prior to setting up and after removing the traffic control installation for single-lane two-way traffic operation, both lanes of traffic must remain open at all times with the exception of temporary single lane closures as may be required by the Contractor for purposes such as loading/unloading.

.2 Maintenance

- a. The Contractor shall be responsible for the maintenance of all traffic control devices and portable temporary traffic signals for the entire duration of the work to ensure the traffic control devices and portable temporary traffic signals are functioning as required to provide for safe traffic operation throughout the worksite at all times. The Contractor shall regularly inspect the traffic control devices and portable temporary traffic signals to ensure proper and safe conditions and shall designate personnel to undertake such inspections and implement corrective measures as required. Such regular inspection shall be undertaken at all times during the course of the work including times when work is being undertaken at the site as well as during times when the work is temporarily shut down such as off-work hours, weekends and holidays.
- b. The Contractor shall supply and install all signage and utilize flag persons as required in accordance with OTM Book 7. The Contractor shall submit and confirm the actual on-site sign locations with the Consultant prior to proceeding with installation.

3.5 MEASUREMENT AND PAYMENT

- .1 Refer to Section 20 Measurement and Payment.

END OF SECTION



SECTION 4 CONCRETE REPAIRS

4.1 DESCRIPTION

- .1 This Specification shall cover the preparation of concrete for, and all concrete repairs and concreting operations related to, the construction of cement concrete works for the Bay Street Overpass, the Darlington Bay Bridge, the Eighth Avenue Bridge, the Matheson Street Bridge, the Parson Street Bridge, the Waste Transfer Station, the Winnipeg River East Branch Bridge, and the Winnipeg River West Branch Bridge, as specified herein.
- .2 The Work to be done by the Contractor under this Specification shall include the furnishing of all superintendence, overhead, labour, materials, equipment, tools, supplies and all things necessary for and incidental to the satisfactory performance and completion of all work as hereinafter specified.

4.2 SCOPE OF WORK

- .1 General
 - a. Concrete Repairs includes the partial or full depth removal of existing concrete and the placement of new concrete on the following components:
 - i. Bay Street Overpass: Soffit
 - ii. Darlington Bay Bridge: Deck Top
 - iii. Eighth Avenue Bridge: Concrete End Dams
 - iv. Matheson Street Bridge: Deck Top
 - v. Parson Street Bridge: Ballast Wall
 - vi. Waste Transfer Station: Exterior Wall and Armouring
 - vii. Winnipeg River East Branch Bridge: Approach Slab, Deck Top, Concrete End Dam, and Concrete Curb/Sidewalk
 - viii. Winnipeg River West Branch Bridge: Deck Top and Concrete End Dam
- .2 Concrete shall be removed within areas of delamination, spalls and/or deterioration. If it is determined a Type 2 Concrete Repair is required, the concrete to be removed may be sound below the delamination or spall, however, shall be removed to a minimum of 25 mm below the existing reinforcing steel as shown on the Drawings. If it is determined a Type 1 Concrete Repair is required, the concrete shall be removed to the middle of exposed rebar as shown on the Drawings. The Contractor shall confirm and further determine the areas of delaminated and/or poor concrete that needs to be removed and repaired. The Consultant will measure and confirm the identified areas determined by the Contractor. For each site, the Contractor shall provide scaffolding to access the areas of concrete that need to be removed for inspection and verification, as required.
- .3 Upon completion of removal, the Contractor shall sand blast clean the existing reinforcing steel, install additional reinforcing steel as required and form and install new concrete. Direction will be provided by the Contract Administrator for the additional reinforcing steel requirements based on the observed condition upon removal and sand blasting.



- .4 Costs for the reinforcing are incidental to the reinforcing steel pay item. All other costs to complete this work, shall be included herein this pay item.

4.3 MATERIALS

.1 General

- a. The Contractor shall be responsible for the supply, safe storage, and handling of all materials set forth in this Specification.
- b. All aggregates shall be handled to prevent segregation and inclusion of any foreign substances, and to obtain uniformity of materials. The two sizes of coarse and fine aggregates, and aggregates secured from different sources, shall be piled in separate stockpiles. The site of the stockpiles shall be cleaned of all foreign materials and shall be reasonably level and firm or on a built-up platform. If the aggregates are placed directly on the ground, material shall not be removed from the stockpile within 150 mm of the ground level. This material shall remain undisturbed to avoid contaminating the aggregate being used with the ground material.
- c. The potential for deleterious alkali-aggregate reactivity shall be assessed in accordance with CSA Standard Test Method A23.2-27A. Current (less than 18 months old) test data evaluating the potential alkali-silica reactivity of aggregates tested in accordance with CSA Standard Test Method A23.2-1 4A or CSA A23.2-25A is required.
- d. Petrographic analysis when performed shall be in accordance with MTO (Ministry of Transportation Ontario) Lab Test Method LS 609. The (weighted) petrographic number shall not exceed 130.

.2 Handling and Storage

- a. All materials shall be handled and stored in a careful and workmanlike manner, to the satisfaction of the Contract Administrator. Storage of materials shall be in accordance with CSA Standard CAN/CSA A23.1.

.3 Testing and Approval

- a. All materials supplied under this Specification shall be subject to inspection and testing by the Contract Administrator or by the Testing Laboratory designated by the Contract Administrator. There shall be no charge to the City for any materials taken by the Contract Administrator for testing purposes.
- b. All materials shall conform to CSA Standard CAN/CSA A23.1.
- c. All testing of materials shall conform to CSA Standard CAN/CSA A23.2.
- d. All materials shall be approved by the Contract Administrator at least twenty-one (21) calendar days before any construction is undertaken. If, in the opinion of the Contract Administrator, such materials, in whole or in part, do not conform to the specification detailed herein or are found to be defective in manufacture or have become damaged in transit, storage or handling operations, then such material shall be rejected by the Contract Administrator and replaced by the Contractor at their own expense.

.4 Concrete Aggregate

- a. The Contractor shall furnish in writing to the Contract Administrator the location of the sources where aggregate will be obtained such that it may be inspected and tentatively



approved by the Contract Administrator. Changes in the source of aggregate supply during the course of the Contract will not be permitted without notification in writing to and the expressed approval of the Contract Administrator.

.5 Fine Aggregate

- a. Fine aggregate shall consist of sand having clean, hard, strong, durable, uncoated grains free from injurious amounts of dust, soft or flaking particles, shale, alkali, organic matter, load or other deleterious substances.
- b. Fine aggregate shall be well-graded throughout and shall conform to the following grading requirements:

Concrete Repairs	
Sieve Size	Percent of Total Dry Weight Passing Each Sieve
10 mm	100%
5 mm	95 – 100%
2.5 mm	80 – 100%
1.25 mm	50 – 90%
630 µm	25 – 65%
315 µm	10 – 35%
160 µm	2 – 10%

- c. For Concrete, the fineness modulus of fine aggregate shall not be less than 2.3 or more than 3.1 unless otherwise approved by the Contract Administrator.

.6 Coarse Aggregate

- a. Standard coarse aggregate shall be used for all the concrete described and required in this Specification.
- b. Standard coarse aggregate shall consist of natural gravel, crushed stone, or other approved materials of similar characteristics, having clean, hard, strong, durable, uncoated particles, free from injurious amounts of soft, friable, thin, elongated, or laminated pieces, alkali, organic, or other deleterious matter. Coarse aggregate shall be well graded throughout and shall conform to the grading requirements in the following table.

Concrete Repairs	
Sieve Size	Percent Passing by Weight
10 mm	85% - 100%
5 mm	10% - 30%
2.5 mm	0% - 10%
1.25 mm	0% - 5%

- c. Concrete shall have a maximum nominal size of coarse aggregate shall be 20 mm and meet the grading requirements of CAN/CSA A23.1, Table 11, Group I. Coarse aggregate shall be uniformly graded and not more than 2% shall pass a 75 um sieve. Coarse aggregate shall consist of crushed stone or gravel or a combination thereof,



having hard, strong, durable particles free from elongation, dust, shale, earth, vegetable matter or other injurious substances. Coarse aggregate shall be clean and free from alkali, organic or other deleterious matter; shall have a minimum of two fractured faces; and shall have an absorption not exceeding 3%.

.7 Cement

- a. All cement, unless hereinafter specifically stated, shall be Type GU Normal Portland Cement.
- b. Cementitious materials shall conform to the requirements of CAN/CSA A3001 and shall be free from lumps.
- c. Should the Contractor choose to include a silica fume admixture in the concrete mix design, the substitution of silica fume shall not exceed 8% by mass of cement.
- d. Should the Contractor choose to include fly ash in the concrete mix design, the fly ash shall be Class CI or F and the substitution shall not exceed 30% by mass of cement.
- e. Cementitious materials shall be stored in a suitable weather-tight building that shall protect these materials from dampness and other destructive agents. Cementitious materials that have been stored for a length of time resulting in the hardening, or the formation of lumps, shall not be used in the Work.

.8 Water

- a. Water used for mixing concrete shall be clean and free from injurious amounts of oil, acid, alkali, organic matter or other deleterious substances. It shall be equal to potable water in physical and chemical properties

.9 Admixtures

- a. No admixtures, other than Air-Entraining Agent and Water Reducing Agent, as specified below, shall be used without the written authorization of the Contract Administrator, unless otherwise specified in these Specifications. It shall be the Contractor's responsibility that each admixture is compatible with all other constituent materials, with respect to the proper performance of the admixture as well as with respect to the proper performance of the other constituents in the presence of the admixture.
 - i. Air Entraining Agent:
The air entraining agent shall conform to the requirements of ASTM Standard C260 and shall produce a satisfactory air-void system and an air content within the ranges specified in CSA Standard CAN/CSA-A23.1 for each class of concrete.
 - ii. Water Reducing Agent:
The water reducing agent shall be Type WN and shall conform to the requirements of ASTM Standard C494.
 - iii. Corrosion Inhibitor:
Corrosion inhibitor shall be MCI 2005 NS at a dosage of 1 L/m³, or equal as accepted by the Contract Administrator.
 - iv. Superplasticizing Agent (High-Range Water Reducer):



Superplasticizing agent shall conform to the requirements of ASTM Standard C494. The agent shall be free of chlorides and shall not affect the air-entraining agent's ability to produce a satisfactory air-void system.

v. Shrinkage Reducing Agent:

Shrinkage reducing admixture shall conform to the requirements of ASTM Standard C157. An approved product is Tetraguard AS20 by Masterbuilders

.10 Patching Mortar

- a. The patching mortar shall be made of the same material and of approximately the same proportions as used for the concrete, except that the coarse aggregate shall be omitted and the mortar shall consist of not more than 1 part cement to 2 parts sand by damp loose volume. White Portland Cement shall be substituted for a part of the grey Portland Cement on exposed concrete to produce a colour matching the colour of the surrounding concrete, as determined by a trial patch. The quantity of mixing water shall be no more than necessary for handling or placing.

.11 Formwork

- a. Unless otherwise indicated on the Drawings, all formwork shall comply as follows:
- i. Formwork materials shall conform to CSA Standard CAN/CSA A23.1 and American Concrete Publication SP 4 "Formwork for Concrete".
 - ii. Form sheeting plywood shall be exterior Douglas Fir, concrete form grade, conforming to CSA 0121, a minimum of 20 mm thick.
 - iii. Boards used for formwork shall be fully seasoned and free from defects such as knots, warps, cracks, etc., which may mark the concrete surface.
 - iv. No formwork accessories will normally be allowed to be left in place within 50 mm of the surface following form removal. However, if the Contract Administrator does permit these items to be left in place, they must be made from a non-rusting material or galvanized steel; and they shall not stain, blemish, or spall the concrete surface for the life of the concrete.
 - v. Forms for exposed surfaces may be either new plywood or steel as authorized by the Contract Administrator.
 - vi. Studding shall be spruce or pine and shall have such dimensions and spacing that they shall withstand without distortion, all the forces to which the forms will be subjected.
 - vii. Walers shall be spruce or pine, with minimum dimensions of 100 mm x 150 mm. Studding shall be spruce or pine, with minimum dimensions of 50 x 150.
 - viii. All forms are incidental to these works and must be removed by the Contractor once adequate strength and curing of the concrete has been achieved.

.12 Plain Formliner

- a. Plain formliner shall be Zemdrain by Dupont, or equal as accepted by the Contract Administrator. This formliner shall be used on all exposed formed surfaces.

.13 Non-Shrink Grout



- a. Where non-shrink grout is used, it shall be Sternson M-bed Standard, CPD Non-Shrink Grout or Sika 212 Non-Shrink Grout. The minimum compressive strength of the grout at 28 days shall be 40 MPa.

.14 Epoxy Grout

- a. Where epoxy grout is used, it shall be Sika Talygrout 100, or equal as accepted by the Consultant.

.15 Flexible Joint Sealant

- a. Flexible joint sealant for all horizontal, vertical, and sloping joints shall be guaranteed non-staining, grey polyurethane, accepted by the Contract Administrator and applied in strict accordance with the details shown on the Drawings and the Manufacturer's instructions including appropriate primers if recommended. Approved products are Vulkem 116 by Mameco, Sonolastic NP1 by Sonneborn, Sikaflex-1a by Sika, Bostik 915 by Bostik, or equal as accepted by the Contract Administrator.

.16 Curing Blankets

- a. Curing blankets for wet curing shall be 100 percent polyester, 3 mm thick, white in colour. An approved product is "Mirafi Geotextile P150". Alternately, a 10 oz burlap, 5 mil polyethylene, curing blanket white in colour shall be used; "Curelap" manufactured by Midwest Canvas, together with a second layer of burlap, or equal as accepted by the Contract Administrator.

.17 Bonding Agents

- a. Bonding agent to bond new concrete to existing concrete areas shall be SikaTop Armatec-110 EpoCem or equal as accepted by the Contract Administrator. Polyvinyl acetate-based latexes shall not be permitted. Planicrete AC by MAPEI is approved for use as a latex bonding agent on concrete greater than 28 days in age.

4.4 CONCRETE DESIGN REQUIREMENTS

.1 Mix Design Statement

- .2 The Contractor shall provide the Contract Administrator with a Mix Design Statement, certifying the constituent materials and mix proportions that will be used in the Portland Cement Concrete. The Contractor shall include, in the certification, the following information:

- i. List the product name and source of all proposed constituent materials of the concrete including cement, coarse aggregate, fine aggregate, water, water reducing agent, and air entraining admixture. A statement is required indicating that the constituent materials proposed for each mix design are compatible with each other, thereby providing concrete with long-term durability capabilities.
- ii. Supply recent records of each mix design for concrete quality control tests including slump, total air content, and 7 and 28-day compressive strengths. The Contractor shall supply reasonable evidence that the mix designs submitted will produce concrete with the specified strength, workability and yield.
- iii. When previously satisfactory strength data on the proposed mix is not available, the Contract Administrator may require the preparation of field trial



batches such that the concrete be tested prior to construction. Such field trial batches shall be carried out in similar conditions and using similar equipment, batching, and mixing procedures as will be used in the actual construction. The number of trial batches required shall be determined by the Contract Administrator and shall depend on the class of concrete materials.

- iv. Supply recent test information, on coarse aggregates of water absorption and abrasion.
 - v. Supply recent information, if available on coarse aggregate alkali-silica reactivity.
 - vi. Supply recent information on tests performed on Portland Cement.
 - vii. Supply any other information deemed applicable.
- .3 The Contractor shall perform the following tests and submit the results to the Contract Administrator prior to the start of construction.
- i. Determine the gradation of fine and coarse aggregates in accordance with CSA Test Method A23.2 2A. Results shall be within acceptable limits specified herein.
 - ii. The Contractor shall submit test data showing that the Contractor's proportioning and mixing equipment, procedures and concrete mix constituent materials can produce a satisfactory air-void system in the hardened concrete. Prior to site mobilization, the Contractor shall prepare and cast representative test specimens of each type of concrete using the same proportioning and mixing equipment and procedures, and the same concrete admixtures as will be employed for the supply and placement of each type of concrete.
- b. As a minimum, the air-void system testing program to be carried out by the Contractor prior to site mobilization must include the following:
- i. Date test specimen cast.
 - ii. Air temperature during casting.
 - iii. Concrete temperature during placement.
 - iv. Air content of the plastic concrete as determined in accordance with CSA Standard Test Method A23.2 4C, "Air Content of Plastic Concrete by the Pressure Method".
 - v. Slump of the plastic concrete as determined in accordance with CSA Standard Test Method A23.2 5C, "Slump of Concrete".
 - vi. Total air-void content, specific surface, spacing factor, and air-paste ratio of the air-void system in the hardened concrete, as determined in accordance with CSA Standard Test Method A23.2 17C, "Microscopical Determination of Air-Void Content and Parameters of the Air-Void System in Hardened Concrete".
 - vii. Density of the hardened concrete.
 - viii. Brand and dosage rate of air-entraining and water-reducing admixtures and any other admixtures used in the test specimens.



- ix. The test specimen concrete will be considered to have a satisfactory air-void system when the average of all tests shows a spacing factor not exceeding 230 microns with no single test greater than 260 microns.
- x. Determine the water-soluble chloride ion content of the hardened concrete in accordance with CSA Test Method A23.2 4B prior to the start of construction.
- xi. All testing shall be carried out by a CSA certified concrete testing laboratory.
- xii. The cost for batching, casting, and testing trial batch specimens shall be incidental to the Supply and Placement of Concrete. No measurement or separate payment will be made for this Work.

.4 Concrete Strength and Workability

- a. The Mix Design Statement shall be submitted to the Contract Administrator at least twenty-one calendar (21) days prior to the delivery of any concrete to the job site. Once accepted by the Contract Administrator, all concrete shall be supplied in accordance with this Statement, which shall be called the Job Mix Formula.
- b. No changes in the Job Mix Formula will be permitted without following the above procedure.
- c. Proportioning of fine aggregate, coarse aggregate, cement, water and air entraining agent shall be such as to yield concrete having the required properties as follows:
 - i. Minimum 28-day strength 30 MPa.
 - ii. Concrete is to be a class of exposure of C-1 with an air content category of 1.
 - iii. The minimum compressive strength of the in-place concrete shall be 30 MPa before it may be subjected to freezing temperatures.
- d. Acceptance of a water reducing agent, superplasticizer (high-range water reducer), or shrinkage reducing admixture is at the discretion of the Contract Administrator.
- e. To avoid the need for mechanical vibration, self-compacting concrete will be considered as a possible alternative to superplasticized concrete if proposed by the Contractor. To be accepted, such concrete must be capable of completely filling the forms and working fully around all reinforcing steel without segregation of the aggregate and without producing voids or honeycombing. The strength characteristics listed above must also be met. Acceptance of any proposed alternate concrete mix design is at the discretion of the Contract Administrator.
- f. The concrete admixture representative shall be present during batching. The workability shall be suitable for the Contractor's approved placement procedures, and to fill all voids.
- g. The Contractor shall submit the proposed mix designs at least two weeks before the commencement of concrete placing operations.

.5 Concrete Supply

- a. Unless otherwise specified in these Specifications of the Contract, only the use of a certified ready mixed concrete plant will be permitted and accepted by the Contract Administrator. Concrete shall be proportioned, mixed and delivered in accordance with the requirements of CSA Standard CAN/CSA A23.1, "Production of Concrete", except



that the transporting of ready mixed concrete in non-agitating equipment is not permitted without the written permission of the Contract Administrator.

- b. Unless otherwise directed by the Contract Administrator, the discharge of ready mixed concrete shall be completed within one and a half (1.5) hours after the introduction of the mixing water to the cement and aggregates.
- c. The Contractor shall maintain all equipment used for handling and transporting the concrete in a clean condition and proper working order.

4.5 EQUIPMENT

.1 General

- a. All equipment shall be of a type accepted by the Contract Administrator. The equipment shall be in good working order, kept free from hardened concrete or foreign materials, and shall be cleaned at frequent intervals.
- b. The Contractor shall have sufficient standby equipment available on short notice at all times.

.2 Vibrators

- a. The Contractor shall have sufficient numbers of concrete vibrators and experienced operators on site to properly consolidate all concrete in accordance with ACI 309. The type and size of vibrators shall be appropriate for the particular application, the size of the pour, and the amount of reinforcing and shall conform to standard construction procedures.
- b. The Contractor shall have standby vibrators available at all times during the pour.

.3 Miscellaneous Equipment

- a. The Contractor shall provide all miscellaneous equipment as required to properly and thoroughly execute and complete all operations related to the supply and placement of concrete.

4.6 CONSTRUCTION METHODS

.1 General

- a. It is intended that this Specification cover the areas to be repaired as indicated approximately on the Drawings. The extent of concrete repairs shall be confirmed with the Contract Administrator in the field prior to commencing the Work.

.2 Preparation

- a. Concrete shall be removed to the limits shown on the Drawings and as confirmed in the field by sounding of the concrete repair area to locate all delaminated areas and mark area off to square or rectangular shapes. All marked areas are to be approved by the Contract Administrator.
- b. Contractor shall prevent damage to adjacent areas on the structure. If the safety of the structure and / or existing structures or services appears to be endangered during structural removal operations, the Contractor shall cease operations and notify the Contract Administrator immediately.



- c. Sawcut around the perimeter of the designated repair areas to 25 mm beyond the closest reinforcing bar, which shall remain intact and uncut. The Contractor shall immediately notify the Contract Administrator if damage to existing reinforcing bars has occurred during the saw cut procedure. Sawcut overlaps at corners of repair areas are not permitted.
 - d. Undercut concrete within the designated repair areas to a depth of 25 mm below the innermost reinforcing bar using a maximum 6 kg chipping hammer. Concrete shall be completely removed from around the reinforcing bars. Ensure the sides of the removal area are straight and square to form a square butt joint with the patch material. There must be 25 mm minimum clear distance between the surface of the concrete and any reinforcing bar after concrete removal. If this cannot be achieved within the designated repair depth, the Contract Administrator may direct additional concrete removal.
 - e. After completion of concrete removals, satisfactory to the Contract Administrator, all resulting concrete and reinforcing steel surfaces shall be sandblasted to remove residual dust, debris, fractured concrete, and contaminants that will inhibit proper bonding. Sandblasting shall be followed by a high pressure water wash to remove all residues. High pressure wash with a minimum pressure of 34.5 MPa (5,000 psi). Existing sound concrete shall be roughened to a 6 mm amplitude.
 - f. The Contractor shall erect screens or hoardings around the work area as required and as directed by the Contract Administrator to protect adjacent property, vehicles, and pedestrians during operations. The Contractor shall take all necessary precautions to ensure that materials does not fall onto active roadways, sidewalks, or waterways.
 - g. In no case shall the Contractor be permitted to use removal equipment, or other equipment or methods which may cause damage to any remaining structural elements or to any new construction. In the event that any element is damaged, the Contractor shall repair such element at his own expense to the satisfaction of the Contract Administrator.
 - h. All sandblasted materials shall be blown out of the repair area, cleaned up, and removed off and away from the project site.
 - i. Repair any over demolition and reinforcing steel damage to the satisfaction of the Contract Administrator.
- .3 Permeable Formwork Liner
- a. Permeable formwork liner shall be used on all exposed surfaces, except on soffit surfaces, or surfaces where an architectural form finish is specified.
 - b. The permeable formwork liner shall be used for only one (1) application.
 - c. The supply, setup, application, and removal of permeable formwork liner shall be considered incidental to the placement of concrete, and no separate measurement or payment shall be made for this Work.
- .4 Anode Installation
- a. Following preparation, install embedded galvanic anodes as indicated on the drawings and directed by the Contract Administrator. Refer to the anode specification section.
- .5 Installation of Reinforcement
- a. Install replacement reinforcing bars as shown on the construction drawings. If necessary, the Contract Administrator may direct that the extent of concrete removal



for a given repair area be increased to achieve the minimum lap length required between the replacement bars and the remaining existing bars.

- b. Remove and replace the existing reinforcing bars if, after blasting, a section loss of 15% or greater of the bar cross-section has occurred or if damaged by the construction activities. Replaced reinforcing bars shall be of the same type and size as the existing bars and spliced with a minimum lap length as follows.

Bar Designation	Tension Lap
10M	400 mm
15M	600 mm
20M	800 mm
25M	1200 mm
30M	1500 mm

- c. If reinforcing steel is found to be corroded, extend the area of removal as directed by the Contract Administrator such that a minimum of 150 mm of non-corroded reinforcing bar is exposed for inspection.
- d. Refer to the reinforcing steel specifications.

.6 Concrete Placement

- a. Prior to installing forms or placing concrete, provide access for the Contract Administrator to inspect the concrete substrate in the repair area. The Contract Administrator, in his discretion, may require additional concrete removal based on the condition of the substrate.
- b. The Contract Administrator must be notified at least two (2) Working Days prior to concrete placement so that an adequate inspection may be made of formwork, shoring, reinforcement, and related Works. Placement without prior notification will not be allowed.
- c. Equipment for mixing or conveying concrete shall be thoroughly flushed with clean water before and after each pour. Water used for this purpose shall be discharged outside the forms. Pumping of concrete will be allowed only on permission from the Contract Administrator and all equipment and processes are subject to this acceptance.
- d. The existing concrete substrate shall be in a saturated surface-dry condition at the time of concrete placement. If necessary, as determined by the Contract Administrator, the Contractor shall erect screens to shade the freshly placed concrete from direct sunlight or wind to prevent excessive rapid drying of the concrete.
- e. For localized repairs where forms are not open at the top, the forms shall be vented at their highest point to allow for air to escape during placement of concrete.
- f. Concrete shall be conveyed from the mixer to the place of final deposit by methods, which will prevent segregation and a marked change in consistency.
- g. Runways for concrete buggies shall be supported directly by the formwork and not on reinforcement.



- h. Before depositing any concrete, all debris shall be removed from the space to be occupied by the concrete, and any mortar splashed upon the reinforcement or forms shall be removed.
 - i. Placing of concrete shall be continuous once started. No concrete shall be placed on concrete which has sufficiently hardened to cause the formation of seams of "cold joints" within the section. If placing must be interrupted, construction joints shall be located where shown on the Drawing or as accepted by the Contract Administrator.
 - j. Concrete shall be placed as nearly as possible in its final position. Rakes or mechanical vibrators shall not be used to transport concrete.
 - k. The maximum drop of free concrete into the forms shall not be greater than 1.5 m otherwise rubber tubes or pouring ports spaced not more than 1.5 m vertically and 2.5 m horizontally shall be used. The Contractor shall obtain the Contract Administrator's acceptance prior to pouring concrete of all placing operations.
 - l. All concrete, during and immediately after depositing, shall be consolidated by mechanical vibrators so that the concrete is thoroughly worked around the reinforcement, around embedded items and into the corners of forms, eliminating all air or stone pockets which may cause honeycombing, pitting, or planes of weakness. Mechanical vibrators shall have a minimum frequency of 7000 revolutions per minute immersed.
 - m. Vibrators shall be inserted systematically into the concrete at intervals such that the zones of influence of the vibrator overlap (generally 300 to 900 mm). Apply the vibrator at any point until the concrete is sufficiently compacted (5 to 15 seconds), but not long enough for segregation to occur. Spare vibrators in working condition shall be kept on the job Site during all placing operations.
 - n. Concrete shall not be placed during rain or snow unless adequate protection is provided for formwork and concrete surfaces.
 - o. Cure concrete in accordance with the curing procedures described herein this Specification.
 - p. After curing, provide access to the Contract Administrator for inspection of the repair areas. If any defects such as delamination are found, the defective area shall be removed and redone to the satisfaction of the Contract Administrator.
 - q. Following curing, supply and apply concrete sealer to all new and existing concrete surfaces in accordance with the requirements described herein this Specification.
- .7 Cleanup
- a. The Contractor will be required to pick up and remove from the site all debris created by the repair procedures to the satisfaction of the Contract Administrator.
- .8 Formwork and Shoring
- a. Formwork shall be designed, erected, braced and maintained to safely support all vertical and lateral loads until such loads can be supported by the concrete all in accordance with CSA Standard CAN/CSA S269.3.
 - b. As a maximum, the following spacings shall apply, for studding and waling:
20 mm plywood: studding - 400 mm centre to centre



Walers - 760 mm centre to centre

- c. Forms shall be clean before use. Plywood and other wood surfaces shall be sealed against absorption of moisture from the concrete by a factory applied liner.
- d. Form accessories to be partially or wholly embedded in the concrete, such as ties and hangers, shall be commercially manufactured types. The portion remaining within the concrete shall leave no metal within 50 mm of the surface when the concrete is exposed to view. Spreader cones on ties shall not exceed 25 mm in diameter.
- e. All exposed edges shall be chamfered 25 mm unless otherwise noted on the Drawings.
- f. Slots, recesses, chases, sleeves, inserts, bolts, hangers and other items shall be formed or set in coordination and cooperation with the trade concerned. No openings shall be made in structural members, which are not shown on the structural Drawings without the prior approval of the Contract Administrator.
- g. Shores shall be provided with positive means of adjustment (jacks or wedges). All settlement shall be taken up before or during concreting as required.
- h. Mud sills of suitable size shall be provided beneath shores, bedded in sand or stone, where they would otherwise bear on soil. The soil below shores must be adequately prepared to avoid settlements during or after concreting. Shores must not be placed on frozen ground.
- i. Brace shores horizontally in two directions and diagonally in the same two vertical planes so that they can safely withstand all dead and moving loads to which they will be subjected.
- j. The loads and lateral pressures outlined in Part 3, Section 102 of "Recommended Practice for Concrete Formwork", (ACI 347) and wind loads as specified by the National Building Code shall be used for design. Additional design considerations concerning factors of safety for formwork elements and allowable settlements outlined in Section 103 of the above reference shall apply.
- k. Formwork shall have sufficient strengths and rigidity so that the resultant finished concrete conforms to the shapes, lines and dimensions of the members shown on the Drawings.
- l. Formwork shall be constructed to permit easy dismantling and stripping and such that removal will not damage the concrete. Provision shall be made in the formwork for shores to remain undisturbed during stripping where required.
- m. Forms shall be constructed and maintained so that the completed work is within minus 3 mm or plus 6 mm of the dimensions shown on the Drawings.
- n. Formwork shall be cambered, where necessary to maintain the specified tolerances, to compensate for anticipated deflections in the formwork due to the weight and pressure of the fresh concrete and due to construction loads.
- o. Forms shall be sufficiently tight to prevent leakage of grout or cement paste.
- p. Form panels shall be constructed so that the contact edges are kept flush and aligned.
- q. Where required by the Contract Administrator, the Contractor shall cast test panels not using less than two panels of representative samples of the forms they proposes for reuse and shall strip them after 48 hours for the Contract Administrator to judge the type of surface produced.



- r. All form lumber, studding, etc., becomes the property of the Contractor when the Work is finished, and it shall be removed from the concrete and the site by the Contractor after the concrete is set, free of extra charge, and the entire site left in a neat and clean condition.
- s. It shall be permissible to use the forms over again where possible to a maximum of 3 uses, provided they are thoroughly cleaned and in good condition after being removed from the former portions of the Work. The Contract Administrator shall be the sole judge of their condition and his decision shall be final regarding the use of them again.

.9 Finishing of Concrete Surfaces

- a. All unformed concrete surfaces shall be finished as outlined hereinafter.
- b. Screeding of all unformed concrete surfaces shall be performed by the sawing movement of a straightedge along wood or metal strips or from edges that have been accurately set at required elevations.
- c. Screeding shall be done on all concrete surfaces as a first step in other finishing operations. Screeding shall be done immediately after the concrete has been vibrated.
- d. After screeding, the concrete shall not be worked further until ready for floating. Floating shall begin when the water sheen has disappeared. The surface shall then be consolidated with hand floats. Concrete surfaces after floating shall have a uniform, smooth, granular texture.

.10 General Curing

- a. The use of curing compound will not be allowed.
- b. Freshly finished concrete shall be covered and kept moist by means of wet polyester blankets immediately following finishing operations and shall be maintained in that condition at above 10°C for a curing period of at least seven (7) consecutive days thereafter.
- c. Concrete shall be protected during the curing period from the harmful effects of sunshine, drying winds, surface dripping, or running water, vibration, and mechanical shock. Concrete shall be protected from freezing until at least 24 hours after the end of the curing period.
- d. Changes in temperature of the concrete shall be uniform and gradual and shall not exceed 3°C in one hour or 20°C in 24 hours.
- e. Surfaces of concrete which are protected by formwork that is left in place for seven (7) days shall not require any additional curing. If forms are removed in less than seven (7) days the concrete shall receive a moist curing as described since the concrete was placed.

4.7 FORM REMOVAL

- .1 The Contract Administrator must be notified at least 24 hours prior to form removal and give approval prior to beginning work.
- .2 The concrete forms shall remain in place a minimum of three (3) days, unless otherwise accepted by the Contract Administrator.



- .3 The minimum strength of concrete in place for safe removal of soffit forms for horizontal or inclined members shall be 30 MPa, with the added provision that the member shall be of sufficient strength to safely carry its own weight, together with super-imposed construction loads, and that the forms shall stay in place a minimum of five days unless otherwise accepted by the Contract Administrator.
- .4 Field-cured test specimens representative of the cast-in-place concrete being stripped, will be tested as specified in this Specification to verify the concrete strength.

4.8 PATCHING OF FORMED SURFACES

- .1 Immediately after forms have been removed but before any repairing or surface finishing is started, the concrete surface shall be inspected by the Contract Administrator. Any repair or surface finishing started before this inspection may be rejected and required to be removed.
- .2 All formed concrete surfaces shall have bolts, ties, struts, and all other timber or metal parts not specifically required for construction purposes cut back seventy-five (75) mm from the surface before patching.
- .3 Minor surface defects caused by honeycombing, air pockets greater than 5 mm in diameter and voids left by strutting and tie holes shall be repaired by removing the defective concrete to sound concrete, dampening the area to be patched and then applying patching mortar. A slurry grout consisting of water and cement, shall be well brushed onto the area to be patched. When the slurry grout begins to lose the water sheen, the patching mortar shall be applied. It shall be struck off slightly higher than the surface and left for one hour before final finishing to permit initial shrinkage of the patching mortar, it shall be touched up until it is satisfactory to the Contract Administrator. The patch shall be cured as specified in this Specification. The final colour shall match the surrounding concrete.
- .4 All objectionable fins, projections, offsets, streaks, or other surface imperfections shall be removed by means acceptable to the Contract Administrator. Cement washes of any kind shall not be used.
- .5 Concrete surfaces shall have a normal finish. Concrete shall be cast against forms, which will produce plane surfaces with no bulges, indentations, or protuberances other than those shown on the Drawings. The arrangement of panel joints shall be kept to a minimum. Panels containing worn edges, patches, or other defects which will impair the texture of concrete surfaces shall not be used.

4.9 COLD WEATHER CONCRETING

- .1 The requirements of this section shall be applied to all concreting operations during cold weather; if the mean daily temperature falls below 5°C during placing or curing.
- .2 The Contract Administrator will advise the Contractor, in writing, as to the degree of heating of water and aggregates.
- .3 Supplementary equipment as required below shall be at the job site if concrete is likely to be placed in cold weather.
- .4 Formwork and reinforcing steel shall be heated to at least 5°C before concrete is placed.
- .5 The temperature of the concrete shall be maintained at not less than 10°C for 7 days or 15°C for 5 days or 20°C for 3 days after placing. The concrete shall be kept above freezing temperature for at least a period of 9 days. In no case, shall the heating be removed until



the concrete has reached a minimum compressive strength which will be specified by the Contract Administrator as determined from compressive strength tests on specimens cured under the same conditions as the concrete Works in question.

- .6 Aggregates shall be heated to a temperature of not less than 20°C and not more than 65°C. Water shall be heated to a temperature between 55°C and 65°C. The temperature of the concrete at the time of placing in the forms shall be within the range specified in CSA Standard CAN/CSA A23.1 for the thickness of the section being placed.
- .7 When the mean daily temperature may fall below 5°C, a complete housing of the Work, together with supplementary heat shall be provided.
- .8 Combustion-type heaters may be used if their exhaust gases are vented outside the enclosures and not allowed to come into contact with concrete surfaces. Fire extinguishers must be readily at hand wherever combustion-type heaters are used.
- .9 When the ambient temperature is below 15°C, the housing shall be constructed so as to allow the concrete to be placed without the housing having to be opened. If the mixing is done outside of the housing, the concrete shall be placed by means of hoppers installed through the housing. The hoppers are to be plugged when not in use.
- .10 When the ambient temperature is equal to or above 15°C, the Contractor will be permitted to open small portions of the housing for a limited time to facilitate the placing of the concrete.
- .11 Before depositing any of the concrete, the Contractor shall show that enough heating equipment is available to keep the air temperature surrounding the forms within the specified range. This shall be accomplished by bringing the temperature inside of the housing to the specified 20°C at least 12 hours prior to the start of the concrete placing.
- .12 The Contractor shall supply all required heating apparatus and the necessary fuel. When dry heat is used, a means of maintaining atmospheric moisture shall be provided.
- .13 Sufficient standby heating equipment must be available to allow for any sudden drop in outside temperatures and any breakdowns, which may occur in the equipment.
- .14 The Contractor shall keep a curing record of each concrete pour. The curing record shall include date and location of the pour, mean daily temperature, temperatures above and below the concrete within the enclosure, temperatures of the concrete surface at several points and notes regarding the type of heating, enclosure, unusual weather conditions, etc. This record shall be available for inspection by the Contract Administrator at all times, and shall be turned over to the Contract Administrator at the end of concreting operations.

4.10 HOT WEATHER CONCRETING

- .1 The requirements of this section shall be applied during hot weather, i.e. air temperatures above 25°C during placing.
- .2 Concrete shall be placed at as low a temperature as possible, preferably below 15°C but not above 27°C. Aggregate stockpiles may be cooled by water sprays and sun shades.
- .3 Ice may be substituted for a portion of the mixing water, providing it has melted by the time mixing is completed.
- .4 Form and conveying equipment shall be kept as cool as possible before concreting by shading them from the sun, painting their surfaces white and/or the use of water sprays.



- .5 Sun shades and wind breaks shall be used as required during placing and finishing.
- .6 Work shall be planned so that concrete can be placed as quickly as possible to avoid "cold joints".
- .7 The Contract Administrator's acceptance is necessary before the Contractor may use admixtures such as retardants to delay setting, or water reducing agents to maintain workability and strength, and these must then appear in the Mix Design Statement submitted to the Contract Administrator.
- .8 Curing shall follow immediately after the finishing operation.
- .9 When the air temperature is at or above 25°C, or when there is probability of its rising to 25°C during the placing period, facilities shall be provided for protection of the concrete in place from the effects of hot and/or drying weather conditions. Under severe drying conditions, as defined below the formwork, reinforcement, and concreting equipment shall be protected from the direct rays of the sun or cooled by fogging and evaporation.
- .10 The temperature of the concrete as placed shall be as low as practicable and in no case greater than that shown below for the indicated size of the concrete section.

Thickness of Section, m	Temperatures (°C)	
	Minimum	Maximum
Less than 0.3	10	27
0.3 – 1	10	27
1.2	5	25

- .11 Moderate Drying Conditions:
 - a. When surface moisture evaporation exceeds 0.75 kg/m²/h, windbreaks shall be erected around the sides of the structural element.
- .12 Severe Drying Conditions
 - a. When surface moisture evaporation exceeds 1.0 kg/m²/h, additional measures shall be taken to prevent rapid loss of moisture from the surface of the concrete. Such additional measures shall consist of the following:
 - i. Erecting sunshades over the concrete during finishing and placing operations.
 - ii. Lowering the concrete temperature.
 - iii. Applying fog spray immediately after placement and before finishing. Care shall be taken to prevent accumulation of water that may reduce the quality of the cement paste.
 - iv. Beginning the concrete curing immediately after trowelling.
 - b. The nomograph, Figure D1, Appendix D of CSA Standard CAN/CSA A23.1 shall be used to estimate surface moisture evaporation rates.
- .13 Construction Joints
 - a. Construction joints shall be located only where shown on the Drawings or as otherwise accepted in writing by the Contract Administrator. Construction joints shall be at right



angles to the direction of the main reinforcing steel. All reinforcing steel shall be continuous across the joints.

- b. The face of joints shall be cleaned of all laitance and dirt, after which an epoxy adhesive bonding agent shall be applied. Forms shall be re-tightened and all reinforcing steel shall be thoroughly cleaned at the joint prior to concreting.

4.11 QUALITY CONTROL

.1 Inspection

- a. All workmanship and all materials furnished and supplied under this Specification are subject to close and systematic inspection and testing by the Contract Administrator including all operations from the selection and production of materials through to final acceptance of the specified Work. The Contractor shall be wholly responsible for the control of all operations incidental thereto notwithstanding any inspection or acceptance that may have been previously given. The Contract Administrator reserves the right to reject any materials or works, which are not in accordance with the requirements of this Specification.

.2 Access

- a. The Contract Administrator shall be afforded full access for the inspection and control testing of concrete and constituent materials, both at the site of Work and at any plant used for the production of concrete, to determine whether the concrete is being supplied in accordance with this Specification.

.3 Materials

- a. All materials supplied under this Specification shall be subject to testing and acceptance by the Contract Administrator.

.4 Concrete Quality

- a. Quality control tests will be used to determine the acceptability of the concrete supplied by the Contractor. All costs for testing shall be covered by the Contractor.
- b. The Contractor shall provide, without charge, the samples of concrete and the constituent materials required for quality control tests and provide such assistance and use of tools and construction equipment as is required.
- c. The frequency and number of concrete quality control tests shall be in accordance with the requirements of CSA Standard CAN/CSA-A23.1.
- d. An outline of the quality tests is as follows:
 - i. Slump tests shall be made in accordance with CSA Standard test method CAN/CSA A23.2 5C, "Slump of Concrete". If the measured slump falls outside the limits specified herein this specification, a second test shall be made.
 - ii. In the event of a second failure, the Contract Administrator reserves the right to refuse the use of the batch of concrete represented.
 - iii. Air content determinations shall be made in accordance with CSA Standard test method CAN/CSA A23.2 4C, "Air Content of Plastic Concrete by the Pressure Method". If the measured air content falls outside the limits specified



herein this Specification, a second test shall be made at any time within the specified discharge time limit for the mix.

- iv. In the event of a second failure, the Contract Administrator reserves the right to reject the batch of concrete represented.
- v. The air-void system shall be proven satisfactory by data from tests performed in accordance with CSA Test Method CAN/CSA A23.1-17C. The spacing factor, as determined on concrete cylinders moulded in accordance with CSA Standard test method CAN/CSA A23.2-3C, shall be determined prior to the start of construction on cylinders of concrete made with the same materials, mix proportions, and mixing procedures as intended for the project. If deemed necessary by the Contract Administrator to further check the air void system during construction, testing of cylinders may be from concrete as delivered to the job site and will be carried out by the Contract Administrator. The concrete will be considered to have a satisfactory air-void system when the average of all tests shows a spacing factor not exceeding 230 microns with no single test greater than 260 microns.
- vi. Samples of concrete for test specimens shall be taken in accordance with CSA Standard Test Method CAN/CSA-A23.2-1C, "Sampling Plastic Concrete".
- vii. Test specimens shall be made and cured in accordance with CSA Standard Test Method CAN/CSA A23.2 3C, "Making and Curing Concrete Compression and Flexure Test Specimens".
- viii. Compressive strength tests at twenty-eight (28) days shall be the basis for acceptance of all concrete supplied by the Contractor. For each twenty-eight (28) day strength test, the strength of two companion standard cured test specimens shall be determined in accordance with CSA Standard Test Method CAN/CSA A23.2 9C, "Compressive Strength of Cylindrical Concrete Specimens", and the test result shall be the average of the strengths of the two specimens. A compressive strength test at seven (7) days shall be taken, the strength of which will be used only as a preliminary indication of the concrete strength, a strength test being the strength of a single standard cured specimen.
- ix. Compressive strength tests on specimens cured under the same conditions as the concrete works shall be made to check the strength of the in place concrete so as to determine if the concrete has reached the minimum compressive strength as specified herein this Specification and also to check the adequacy of curing and/or cold weather protection. At least two (2) field cured test specimens will be taken to verify strength of the in place concrete. For each field cured strength test, the strength of a single field cured test specimen shall be determined in accordance with CSA Standard test method CAN/CSA A23.2-9C, "Compressive Strength of Cylindrical Concrete Specimens", and the test result shall be the strength of the specimen.

.5 Corrective Action

- a. If the results of the tests indicate that the concrete is not of the specified quality, the Contract Administrator shall have the right to implement additional testing, as required, to further evaluate the concrete at the Contractor's expense. The Contractor shall, at his own expense, correct such work or replace such materials found to be defective under this Specification in an approved manner to the satisfaction of the Contract Administrator.



4.12 MEASUREMENT AND PAYMENT

- .1 Refer to Section 20 Measurement and Payment.

END OF SECTION



SECTION 5 SUPPLY AND PLACE REINFORCING STEEL

5.1 DESCRIPTION

- .1 This Specification shall cover all operations relating to the supply, fabrication, and placement of concrete reinforcement, and associated bar accessories, as specified herein and as shown on the Drawings. This specification applies to both new reinforcing and existing reinforcing that is being replaced due to damage and/or corrosion section loss.
- .2 The work to be done by the Contractor under this Specification shall include the furnishing of all superintendence, overhead, labour, materials, equipment, tools, supplies, and all other ancillary items necessary for and incidental to the satisfactory performance and completion of all Work as hereinafter specified.

5.2 MATERIALS

- .1 General
 - a. The Contractor shall be responsible for the supply, safe storage, and handling of all materials set forth in this Specification.
- .2 Handling and Storage of Materials
 - a. All materials shall be handled in a careful and workmanlike manner, to the satisfaction of the Contract Administrator. Storage of materials shall be in accordance with the requirements of CSA Standard CAN3-A23.1, Storage of Materials, latest edition, except as otherwise specified herein.
 - b. The Contractor shall handle and store the reinforcing steel in a manner that ensures it is not damaged or contaminated with dirt or other materials.
 - c. The reinforcing steel shall not be placed directly on the ground. Timber pallets or other suitable supports shall be placed under the reinforcing steel to keep them free from dirt and mud and to provide easy handling.
- .3 Reinforcing Steel
 - a. Reinforcing steel shall be deemed to include all reinforcing bars, tie-bars, supports, tie wire, and dowels.
 - b. All reinforcing steel shall be black steel and conform to the requirements of latest edition of CSA Standard CAN/CSA G30.18, Grade 400 MPa, Billet-Steel Bars for Concrete Reinforcement. If, in the opinion of the Contract Administrator, any reinforcing steel provided for the concrete works exhibit flaws in the manufacture or fabrication, such material shall be immediately removed from the site and replaced with acceptable reinforcing steel.
 - c. Reinforcing deformations shall conform to the requirements of ASTM A615M. All hooks and bends shall be bent using pin diameters and dimensions recommended by RSIC.
 - d. All reinforcing steel shall be straight and free from paint, oil, millscale, and injurious defects. Rust, surface seams, or surface irregularities will not be cause of rejection, provided that the minimum dimensions, cross-sectional area, and tensile properties of a hand wire-brushed specimen are not less than the requirements of CSA Standard CAN/CSA G30.18.



.4 Bar Accessories

- a. Bar accessories shall be of a type acceptable to the Contract Administrator. They shall be made from a non-rusting material or galvanized steel, and they shall not stain, blemish, or spall the concreted surface for the life of the concrete. Bar chairs are to be PVC; galvanized bar chairs are not acceptable.
- b. Bar accessories are not included in the Drawings and shall include bar chairs, spacers, clips, wire ties, wire (18 gauge minimum), or other similar devices and are to be acceptable to the Contract Administrator. The supplying and installation of bar accessories shall be deemed to be incidental to the supplying and placing of reinforcing steel.

.5 Epoxy

- a. Epoxy for epoxy grouting reinforcing bars into the existing concrete shall be Hilti HIT-RE 500 V3.

5.3 CONSTRUCTION METHODS

.1 Fabrication of Reinforcing Steel

- a. Reinforcing steel shall be fabricated in accordance with the latest edition of CSA Standard CAN/CSA G30.18, to the lengths and shapes as shown on the Drawings.

.2 Placing of Reinforcing Steel

- a. Reinforcing steel shall be placed accurately in the positions shown on the Drawings and shall be retained in such positions by means of a sufficient number of bar accessories so that the bars shall not be moved out of alignment during or after the depositing of concrete. The Contract Administrator's decision in this matter shall be final.
- b. Reinforcing steel shall be free from all foreign material in order to ensure a positive bond between the concrete and steel. The Contractor shall also remove any dry concrete, which has been deposited on the steel from previous concrete placement operations before additional concrete may be placed. Intersecting bars shall be tied positively at each intersection.
- c. Splices in reinforcing steel shall be made only where indicated on the Drawings. Prior approval of the Contract Administrator shall be obtained where other splices must be made. Welded splices will not be permitted.
- d. Existing reinforcement shall be replaced with new when the existing reinforcing steel has section loss of 15% or greater. The replacement reinforcing shall be placed accurately and in-line with existing reinforcing and shall be of the same type and size. Laps, when required shall be typical Class B splices for reinforcing steel.
- e. When required, the replacement reinforcing steel shall be drilled and epoxy grouted into the existing concrete with a minimum embedment depth of 300 mm, as specified on the Drawings, or as directed by the Contract Administrator.
- f. Reinforcing steel shall not be straightened or re-bent in a manner that will injure the metal. Bars with bends not shown on the Drawings shall not be used. Heating of reinforcing steel will not be permitted without prior approval of the Contract Administrator. A minimum of twenty-four (24) hours advance notice shall be given to



the Contract Administrator prior to the placement of any concrete to allow for inspection of the reinforcement.

.3 Quality Control

a. Inspection

All workmanship and all materials furnished and supplied under this Specification are subject to close and systematic inspection and testing by the Contract Administrator including all operations from the selection and production of materials through to final acceptance of the specified Work. The Contractor shall be wholly responsible for the control of all operations incidental thereto notwithstanding any inspection or acceptance that may have been previously given. The Contract Administrator reserves the right to reject any materials or works, which are not in accordance with the requirements of this Specification.

b. Access

The Contract Administrator shall be afforded full access for the inspection and control testing of reinforcing steel; both at the Site of Work and at any plant used for the fabrication of the reinforcing steel, to determine whether the reinforcing steel is being supplied in accordance with this Specification.

c. Quality Testing

The Contractor shall submit certificates and mill test results for the material to be supplied. Traceability is required for all reinforcing.

Quality control testing will be used to determine the acceptability of the reinforcing steel supplied by the Contractor.

The Contractor shall provide, without charge, the samples of reinforcing steel required for quality control tests and provide such assistance and use of tools and construction equipment as is required.

5.4 MEASUREMENT AND PAYMENT

- .1 Refer to Section 20 Measurement and Payment.

END OF SECTION



SECTION 6 SUPPLY AND INSTALLATION OF GALVANIC ANODES

6.1 DESCRIPTION

- .1 This Specification shall cover furnishing all labour, tools, materials, equipment and services necessary to properly install embedded galvanic anodes.
- .2 Embedded galvanic anodes are designed to provide localized corrosion protection. When placed at the appropriate spacing along the perimeter of concrete patches or along the interface between new / existing concrete, the anodes mitigate active corrosion and the formation of new corrosion sites in the adjacent existing concrete.

6.2 MATERIALS

- .1 General
 - a. The Contractor shall be responsible for the supply, safe storage, and handling of all materials set forth in this Specification.
- .2 Handling and Storage of Materials
 - a. All materials shall be handled in a careful and workmanlike manner, to the satisfaction of the Contract Administrator. Storage of materials shall be in accordance with the manufacturer's recommendations.
- .3 Embedded Galvanic Anodes
 - a. Embedded galvanic anodes shall be Anode Type 1A Class P with the following nominal dimensions: 125 mm x 25 mm x 25 mm. The anodes shall be pre-manufactured with a nominal 60 grams of zinc in compliance with ASTM B418 Type II cast around a pair of uncoated, non-galvanized steel tie wires and encased in a highly alkaline cementitious shell with a pH of 14 or greater.
 - b. The anode unit shall contain no added sulfate nor shall it contain added chloride, bromide or other constituents that are corrosive to reinforcing steel. Anode units shall be supplied with integral unspliced wires for directly tying to the reinforcing steel. Embedded galvanic anodes shall be Vector Corrosion Technologies Galvashield XPT or approved equal.
 - c. Application for galvanic anode approved equals shall include verification of the following information:
 - i. The zinc anode is alkali-activated with an alkaline cementitious shell with a pH of 14 or greater.
 - ii. Contain no added constituents corrosive to reinforcing steel or detrimental to concrete, e.g. chloride, bromide, sulfate, etc.
 - iii. Documented test results from field installations showing that the anodes have achieved a minimum of 10 years in service.
 - iv. A minimum of ten projects of similar size and application
 - v. Anode units shall be supplied with solid zinc core (ASTM B418) cast around uncoated non-spliced steel tie wires for wrapping around the reinforcing steel



and twisting to provide a durable steel to steel connection between the tie wire and the reinforcing steel.

- vi. Third party product evaluation, such as from Concrete Innovations Appraisal Service, BBA, etc.

.4 Repair Materials

- a. Repair mortars, concrete and bonding agents shall be Portland cement-based materials with suitable electrical conductivity less than 15,000 ohm-cm. Non-conductive repair materials such as epoxy, urethane, or magnesium phosphate shall not be permitted. Repair materials with significant polymer modification and/or silica fume content may have high resistivity. Insulating materials such as epoxy bonding agents shall not be used unless otherwise called for in the design.
- b. If higher resistance repair materials are used, or the resistivity is unknown, use Galvashield Embedding Mortar to create a conductive bridge to the substrate prior to repair material installation.
- c. All reinforcing steel shall conform to the requirements of latest edition of CSA Standard CAN/CSA G30.18, Grade 400 MPa, Billet-Steel Bars for Concrete Reinforcement.

.5 Storage

- a. Deliver, store, and handle all materials in accordance with manufacturer's instructions. Anode units shall be stored in dry conditions in the original unopened containers in a manner to avoid exposure to extremes of temperature and humidity.

6.3 CONSTRUCTION METHODS

.1 Concrete Removal

- a. Preparation and removal of deteriorated concrete shall be performed in accordance with Section 4 Concrete Repairs.

.2 Cleaning and Repair of Reinforcing Steel

- a. Clean exposed reinforcing steel of rust, mortar, etc. to provide sufficient electrical connection and mechanical bond.
- b. If significant reduction in the cross section of the reinforcing steel has occurred, replace or install supplemental reinforcement as directed by the Contract Administrator in accordance with the drawings and Section 5 Supply and Place Reinforcing Steel.
- c. Secure loose reinforcing steel by tying tightly to other bars with steel tie wire.
- d. Verify electrical continuity of all reinforcing steel, including supplemental steel.
- e. If the reinforcing steel is to receive a barrier coating, do not coat the reinforcing steel within 25 mm of the anode and do not apply coating to any surface of the anode or the steel tie wires.

.3 Galvanic Anode Installation

- a. Install anode units and repair material immediately following preparation and cleaning of the steel reinforcement.



- b. Galvanic anodes shall be installed in a grid pattern throughout the entire repair area at a maximum spacing of 500 mm.
 - c. Place the galvanic anodes as close as possible to the patch edge while still providing sufficient clearance between anodes and substrate to allow the repair material to fully encase the anode with a minimum concrete or mortar cover over the anode of 25 mm. If necessary, increase the size of the repair cavity to accommodate the anodes.
 - i. Place the anode such that it is attached to a single bar or at the intersection between two bars and secure to each clean bar.
 - ii. If less than 25 mm of concrete cover is expected, place anode beneath the bar and secure to clean reinforcing steel.
 - d. The tie wires shall be wrapped around the cleaned reinforcing steel at least one full turn in opposite directions and then twisted tight to create a secure electrical connection and allow no anode movement during concrete placement.
 - e. If repair materials with resistivity greater than 15,000 ohm-cm are to be used or if the resistivity is unknown, pack Galvashield Embedding Mortar, or approved equal, between the anode and the substrate concrete to create a conductive grout bridge ensuring no voids exist.
 - f. Confirm electrical connection between anode tie wire and reinforcing steel by measuring DC resistance (ohm) or DC potential (mV) with a multi-meter.
 - g. Electrical connection is acceptable if the DC resistance measured with the multi-meter is 1 ohm or less or the DC potential is 1 mV or less.
 - h. Confirm electrical continuity of the exposed reinforcing steel within the repair area. If necessary, electrical continuity shall be established by tying discontinuous steel to continuous steel using steel tie wire.
 - i. Electrical continuity between test areas is acceptable if the DC resistance measured with multi-meter is 1 ohm or less or the potential is 1 mV or less.
- .4 Concrete Mortar Replacement
- a. If the repair procedures require the concrete surface to be saturated with water, do not damage the anode nor allow the anode units to be soaked for greater than 20 minutes.
 - b. Complete the repair with the repair material, taking care not to damage, loosen or leave voids around the anode.

6.4 MEASUREMENT AND PAYMENT

- .1 Refer to Section 20 Measurement and Payment.

END OF SECTION



SECTION 7 OVERHEAD CONCRETE REPAIRS

7.1 DESCRIPTION

- .1 This Specification shall cover the preparation, repairs, and operations related to the repair of concrete soffit for the Bay Street Bridge as specified herein.
- .2 The Work to be done by the Contractor under this Specification shall include the furnishing of all superintendence, overhead, labour, materials, equipment, tools, supplies, and all other ancillary items necessary for and incidental to the satisfactory performance and completion of all Work as hereinafter specified.

7.2 SCOPE OF WORK

- .1 Overhead concrete repairs include the partial removal of existing unsound concrete and the placement of new mortar on the Bay Street Bridge soffit as shown on the Drawings.

7.3 MATERIALS

- .1 Products shall be delivered, stored and handled in accordance to the manufacturer's recommendations and/or specification.
- .2 Products shall be protected from water, humidity and excessive cold and heat throughout delivery, storage, placement and curing.
- .3 Products that are damaged or contaminated shall not be used.
- .4 If the manufacturer's recommendations and/or specification are not available, the Contract Administrator shall be contacted to provide delivery, storage and handling recommendations.
- .5 Repair Mortar shall be Sika MonoTop 623 F or equivalent as accepted by the Contract Administrator.

7.4 CONSTRUCTION METHODS

- .1 Preparation
 - a. All operations shall only be carried out when the air and concrete surface temperature is higher than 5 °C.
 - b. Concrete shall be high-pressure waterblasted, chipped, or shall be removed by other appropriate mechanical means and be removed within areas of delamination, spalls and or deterioration to sound concrete. The Contractor shall confirm and further determine the areas of delaminated and / or poor concrete that needs to be removed and repaired. The Contract Administrator will measure and confirm the identified areas determined by the Contractor.
 - c. Remove all dirt, oil, grease, and other bond inhibiting materials from surface before mortar installation.
 - d. The existing concrete should be in a saturated surface dry condition prior to installation of mortar with no standing water or glistening water films during application.



- e. Mix product according to manufacturer's instructions.
- .2 Installation
- a. Installing and forming the mortar shall be completed according to manufacturer's instructions.
 - b. The edges of the mortar shall be flush with the existing soffit and fascia so as to create a seamless transition from the existing concrete to the mortar, as deemed acceptable by the Contract Administrator.
 - c. Repaired areas that are not flush with the adjacent soffit and fascia concrete will be rejected and shall be repaired by the Contractor at no additional cost to the Contract.
 - d. Forms for soffit patches shall not be removed until the full design strength has been reached.

7.5 MEASUREMENT AND PAYMENT

- .1 Refer to Section 20 Measurement and Payment.

END OF SECTION



SECTION 8 ASPHALT AND WATERPROOFING MEMBRANE REPAIR

8.1 DESCRIPTION

- .1 This Specification shall cover all operations relating to the supply, and installation of asphaltic products for the remediation of asphalt and waterproofing membrane between concrete bridge decks and asphalt overlay.
- .2 The work to be done by the Contractor under this Specification shall include the furnishing of all superintendence, overhead, labour, materials, equipment, tools, supplies, and all things necessary for and incidental to the satisfactory performance and completion of all Work as hereinafter specified.

8.2 SCOPE OF WORK

- .1 This Specification shall cover all operations relating to the patching of the damaged asphalt and waterproofing membrane at the Darlington Bay Bridge, the Eighth Avenue Bridge, the Matheson Street Bridge, the Winnipeg River East Branch Bridge, and the Winnipeg River West Branch Bridge, as shown on the Drawings.

8.3 MATERIALS

- .1 Products shall be delivered, stored and handled in accordance with the manufacturer's recommendations and/or specification.
- .2 Products shall be protected from water, humidity, and excessive cold and heat throughout delivery, storage, placement and curing.
- .3 Products that are damaged or contaminated shall not be used.
- .4 If the manufacturer's recommendations and/or specification are not available, the Contract Administrator shall be contacted to provide delivery, storage and handling recommendations.
- .5 Primer Coat
 - a. Bemalastic 910 or approved equivalent water proofing shall be used.
 - b. Used in conjunction with the asphalt membrane, shall be primer cut-back with an equal volume of gasoline type solvent or an acceptable alternative cut-back asphalt product. The primer shall conform to CAN/CGSB-37-GP-9M
 - c. Used in conjunction with the protection board, shall be SS-1 emulsion diluted with an equal volume of water. The SS-1 emulsion shall conform to OPSS 1103.
- .6 Asphalt Membrane
 - a. Bemalastic 1213 BDM or approved equivalent shall be used.
 - b. Shall be two-ply hot applied rubberized asphalt conforming to OPSS 1213 and shall be supplied to the job site in cakes in the manufacturer's sealed and labelled containers ready for melting and application.
- .7 Protection Board



- a. Vibraflex or approved equivalent shall be used.
 - b. Protection board shall be 3.6 mm thick x 1000 mm x 1500 mm.
 - c. Tolerance: Thickness +/- 0.4 mm; Length +/- 150 mm; Width +/- 150 mm.
- .8 Asphalt
- a. Quality of asphaltic pavement placed shall follow and adhere to the OPSS 1150 – Material Specification for Hot Mix Asphalt Mix Type HL4.
- .9 Hot Poured Sealant
- a. Sealant shall be hot poured rubberized asphalt sealant in accordance with OPSS 1212.

8.4 CONSTRUCTION METHODS

.1 Preparation

- a. All operations shall only be carried out when the air and concrete surface temperature is at 2°C or higher.
- b. Sawcut around the existing damaged asphalt area to the dimensions shown on the drawings. Sawcut down to the protection board but not damaging the waterproofing membrane below.
 - i. Sawcut shall be 250 mm beyond the asphalt damage limits in the transverse direction and 500 mm beyond the asphalt damage limits in the longitudinal direction.
 - ii. Contractor to verify asphalt removal limits with Contract Administrator prior to completing the work.
- c. Remove and dispose of the asphalt taking care to not damage the perimeter of waterproofing membrane below the undamaged asphalt area.
- d. Remove waterproofing membrane below the area of damaged asphalt. A minimum of 150 mm of existing undamaged waterproofing membrane shall remain around the outside perimeter of the damaged area.
- e. Any repairs or remedial work to the deck top which may be required prior to abrasive blast cleaning and not provided for in the Contract shall be the preformed by the Contractor and shall be administered under “Extra Work” procedures of the General Conditions.
- f. Blast clean the concrete to expose sound, laitance-free concrete. All dirt and debris shall be swept off and disposed of before tack coating. Immediately prior to the application of the tack coat, the concrete surface shall be cleaned with a jet of oil-free compressed air to remove all dust and any other foreign material.

.2 Installation

- a. The primer coat shall be applied when the concrete is dry and clean. The mixture shall be applied at the rate of 0.25 L/m². Shall be applied with approved equipment which will provide a uniform application at the required rate. Waterproofing equipment will not be permitted upon the primer coat until it has fully cured.



- b. Apply primer coat and allow to cure according to manufacturer requirements, lapping existing undamaged membrane by a minimum of 150 mm.
- c. The application rate shall be such that the primer material will be absorbed into the concrete, resulting in a surface that is dull and black in appearance. The application of an excessive amount of primer as indicated by a shiny black surface shall be avoided.
- d. The first layer of nominal 5 mm hot applied asphalt membrane shall be applied when the primer coat has cured completely, free of any surface moisture and dirt.
- e. Cakes of asphalt membrane shall be melted on the job site in the mechanically agitated heating and mixing kettle. The unit shall keep the contents continuously agitated until the material can be drawn free flowing and lump free from the mixing kettle at a temperature within the range recommended by the manufacturer.
- f. The first layer of membrane shall be applied within the temperature range recommended by the manufacturer, to the clean, primer coated concrete deck, so as to form a uniform film having a nominal thickness of 5 mm lapping existing undamaged membrane by 150 mm. The laying operation shall be continuous and if discontinuities cannot be avoided, they shall be lapped 150 mm. Allow to cure according to manufacturer requirements.
- g. The membrane reinforcement shall be placed in accordance with the manufacturer's installation instructions directly over the asphalt membrane and pressed in while it is still tacky to achieve a minimum of 50% bleed through.
- h. The second layer of membrane shall be applied otop of the membrane reinforcement following the same requirements and thickness as the first layer.
- i. Protection boards shall be laid on the asphalt membrane while the surface is still tacky with the length of the board transverse on the deck. Materials or substances shall not be applied to the membrane surface to remove the tackiness prior to installation of the protection board.
- j. Protection boards shall be placed such that the longitudinal (direction of traffic flow) joints are staggered a minimum of 150 mm. Protection boards shall be cut on the long side at the 1/3 location to allow for this staggered joint installation. The longitudinal joint in each board shall alternate from and be staggered.
- k. Protection boards shall be placed with edges overlapping 12 mm +/- 6 mm both longitudinally and transversely. Edges of the new boards shall butt up against the existing protection boards.
- l. Protection boards shall be rolled by means of a linoleum or lawn type roller while the membrane is still warm, in order to ensure good contact with the membrane.
- m. In instances where edges of the protection board curl up, the edges shall be cemented down using hot membrane material to the satisfaction of the Contract Administrator. Protection boards that are warped, distorted or damaged in any way, by manufacture, storage, handling or exposure to weather, shall be rejected. Costs to replace the damaged boards shall be the responsibility of the Contractor and there shall be no change to the contract price.
- n. The primer coat shall be applied only when the protection board is dry and clean. The primer coat on the protection board cover shall be placed just sufficiently ahead of paving to allow for curing. The diluted primer coat material shall be applied at the rate



of 0.5 L/m². Paving equipment shall not be permitted upon the primer coat until it has fully cured.

- o. Place asphalt on the primer coat according to OPSS 310 – Construction Specification for Hot Mix Asphalt Mix Type HL4.

.3 Environmental Protection

- a. The following environmental protection measures are to be implemented:
 - i. All material runs or spills and any foreign materials shall be carefully removed from the surface and not allowed to enter the waterway or to collect on the ground.
 - ii. The waste materials collected shall be disposed of in the appropriate manner away from the Work Site.

.4 Rout and Seal

- a. As noted on the drawings, interfaces of new asphalt with existing asphalt shall be routed, cleaned, and sealed as specified.
- b. Rout to a width and depth of 20 mm x 20 mm.
- c. Remove dust and loose particles with an oil free air jet having sufficient volume and pressure, immediately before placement of the sealant material.
- d. The sealant compound shall be melted slowly with constant agitation until it is in a lump-free, free-flowing state, within the temperature range recommended by the manufacturer for application. The temperature of the sealant shall be monitored and recorded. The temperature records shall be made available to the Contract Administrator upon request.
- e. Before sealant application, all loose debris from the routing and cleaning operation shall be completely removed. All moisture, debris, and loose fractured aggregate shall be removed from the routed joints immediately prior to the time the sealant compound is being placed.
- f. Place sealant immediately following cleaning, the sealant compound shall be placed using either a manual pouring cone filled from a spigot located on the heating kettle itself, or by using a hose and wand fitted with the proper sized tip that allows the sealant to be pumped directly from the heating kettle into the routed joint. The tip of the cone or wand shall be placed to the bottom of the joint to ensure uniform application.
- g. Place joint sealant so that, upon complete cooling, the top of the sealant is 4 to 6 mm below the adjacent pavement surface.
- h. A squeegee, with its bottom edge trimmed to form the specified dimensions of the finished sealant surface after cooling, shall be used to strike off the sealant after it is poured into the routed joint. The sealant shall be struck off starting from the low side and working towards the high side of the pavement surface. In order to maintain the sealant surface dimensions, the sealant shall be topped up and struck off again. Sealant compound damaged by construction traffic or the Contractor's operation shall be replaced.
- i. Complete sealing when surface is dry. Place sealant at ambient temperature of at least 4°C and rising.



- j. No traffic or construction equipment will be allowed to travel over the sealed joints until such time as the sealant has cooled to atmospheric temperature.
- k. Reheating of unused joint sealants will not be permitted.
- l. Remove off site all debris from the routing and cleaning operations to the satisfaction of the Contract Administrator.

8.5 QUALITY ASSURANCE

.1 Sampling and Testing

- a. The Contract Administrator may at their discretion, require that sufficient quantities of the asphalt membrane, or membrane reinforcement be obtained from the materials being used on the project for testing purposes.

.2 Acceptance of Membrane Thickness

- a. The Contract Administrator will determine the acceptability of the waterproofing membrane thickness based on tests completed by the Contract Administrator.
- b. Each test result will consist of the three measurements taken at the corners of an imaginary triangle centered about a random location. Each side of the imaginary triangle will be approximately 0.1 m long. The three measurements will be averaged, rounded to the closest 1 mm and reported as one test result.
- c. Two test results will be required, spread throughout the repair area.
- d. ASTM D4114-95 Standard Practice for Measurement of Wet-Film Thickness by Notch Gauges shall be used.
- e. Test results less than 5 mm will not be acceptable.

8.6 MEASUREMENT AND PAYMENT

- .1 Refer to Section 20 Measurement and Payment.

END OF SECTION



SECTION 9 TIMBER PLANKS AND WOOD TREATMENT

9.1 DESCRIPTION

- .1 This Specification shall cover all operations for the supply, delivery, and installation of timber planks at the CPR Pedestrian Bridge and timber stair stringers at the Portage Bay Walkway Bridge, as noted on the Drawings, and all operations relating to the work necessary for the treatment of wood, as herein specified.
- .2 The Work to be done by the Contractor under this Specification shall include the furnishing of all superintendence, overhead, labour, materials, equipment, tools, supplies, and all other ancillary items necessary for and incidental to the satisfactory performance and completion of all Work as hereinafter specified

9.2 SCOPE OF WORK

- .1 The work shall include the supply, delivery, and installation of timber planks in accordance with the details shown on the Drawings, and the treatment of wood, if required.
- .2 The Contractor shall submit a fastening sequence for the installation of the timber deck planks and timber stair treads.
- .3 The Contractor shall either tighten or replace loose fasteners at the CPR Pedestrian Bridge, as confirmed with the Contract Administrator in the field.
- .4 For products treated with preservative by pressure impregnation, submit the following information certified by an authorized signing officer of the treatment plant as requested by the Contract Administrator:
 - a. Information listed in AWPA-M2 applicable to specified treatment.
 - b. Moisture content after drying following treatment.

9.3 QUALITY ASSURANCE

- .1 Lumber identification by grade stamp of an agency certified by Canadian Lumber Accreditation Board.

9.4 MATERIALS

- .1 General
 - a. The Contractor shall be responsible for the supply, safe storage, and handling of all materials as set forth in this Specification.
 - b. All materials supplied under this Specification shall be of a type accepted by the Contract Administrator and shall be subject to inspection and testing by the Contract Administrator.
 - c. All timber materials shall be supplied and installed in accordance with CSA-086.
- .2 Handling and Storage of Materials



- a. Timber brought to the site shall be carefully handled to avoid damaging the outer fibres. Dropping of timber from the truck to the ground will not be allowed.
 - b. Special tools and slings shall be employed to prevent the penetration or bruising of the treated surfaces. The use of tongs, chains, or other sharp tools for handling purposes will not be allowed.
 - c. The timber shall be stored in an orderly fashion and may be stacked in neat, regular piles. Large pieces shall be spaced to allow the use of slings. Piled materials shall be closely stacked to prevent warping. The bottom pieces in each pile shall be placed on blocks to prevent bending of the member.
- .3 Timber Planks
- a. Timber decking and other timber components shall conform to NLGA Standards Grading Rules for Canadian Lumber.
 - b. Timber decking shall be Select Structural Grade.
- .4 Fasteners
- a. Fasteners shall be hot dip galvanized or stainless steel and shall be compatible with the preservation treatment of the timber.
- .5 Preservative Treatments
- a. Treat timber components using ACQ preservative to obtain minimum net retention as specified in CSA-080.

9.5 CONSTRUCTION METHODS

- .1 Field Framing
- a. Cutting and framing of treated timber shall be done by the supplier before treatment; however, field cutting, fitting, and matching may be required as indicated on the Drawings. The Contractor shall make the necessary cuts and holes in a true and efficient manner. All cuts shall be treated per clause 10.5.3.
 - b. All timber from which the seal of treatment has been removed due to mishandling by the Contractor will be rejected and replacement shall be made at the Contractor's expense, or if permitted by the Contract Administrator, the Contractor shall apply timber preservative to the damaged surface. The Contractor shall apply one heavy coat of timber preservative to all areas where the seal of treatment has been removed or partially removed in the process of field cutting and framing.
- .2 Timber Plank Installation
- a. Timber planks shall be installed in accordance with the Drawings.
 - b. The trimmed edge of the planks shall be made flush.
 - c. Timber planks shall be secured to the bridge and stairs as shown on the Drawings.
- .3 Field Treatment of Preservative – Treated Products
- a. Remove with fine sandpaper, chemical deposits on treated wood to receive applied finish.



- b. Field cut members, damaged, or drilled members shall receive two coats of end cut preservative treatment. Treat field cuts and end cuts for all wood with a preservative product according to CSA use category UC4.2.

9.6 MEASUREMENT AND PAYMENT

- .1 Refer to Section 20 Measurement and Payment.

END OF SECTION



SECTION 10 CLEAR VEGETATION FROM EMBANKMENTS

10.1 DESCRIPTION

- .1 This Specification shall cover all operations relating to the removal of vegetation on the embankments at the Eighth Avenue Bridge, the First Avenue Bridge, the Matheson Street Bridge, and the Parson Street Bridge.

10.2 SCOPE OF WORK

- .1 This Section includes all works associated with vegetation removal/clearing at bridge embankments as shown on the Drawings.
- .2 Vegetation, including small trees and shrubs with trunks up to 75 mm diameter, shall be cut down to grade level at the embankment locations as shown on the Drawings. Tree trunks and shrubs shall be cut approximately parallel to ground line to avoid leaving sharp surfaces. Prior to work beginning, the Contract Administrator shall identify any trees or vegetation that is to remain in place.
- .3 Trees larger than 75 mm diameter which may be required to be removed and are not provided for in the Contract shall be the performed by the Contractor and shall be administered under "Extra Work" procedures of the General Conditions.

10.3 MEASUREMENT AND PAYMENT

- .1 Refer to Section 20 Measurement and Payment.

END OF SECTION



SECTION 11 BRIDGE JOINT SEAL REPLACEMENT

11.1 DESCRIPTION

- .1 This Specification shall cover the removal of existing joint seals and supply and installation of new joint seals and miscellaneous steel items, as specified herein and shown on the Drawings.
- .2 The Work to be done by the Contractor under this Specification shall include the furnishing of all superintendence, overhead, labour, materials, equipment, tools, supplies, and all things necessary for and incidental to the satisfactory performance and completion of all work as hereinafter specified.

11.2 SCOPE OF WORK

- .1 The work shall include the removal and disposal of the existing bridge joint seals, cleaning and preparation of existing steel extrusion and recesses for receiving new joint seals, supply and installing new bridge joint seals, completing a watertight verification of the joint seals, and re-installing the joint cover plates and other miscellaneous steel items, as required to install the new bridge joint seals.
- .2 The Contractor shall replace in kind the joint seals as indicated on the Drawings. The Contractor shall submit technical data sheets, drawings, and specifications of the proposed joint seal models to be used for the joint seal replacements to the Contract Administrator for review and approval prior to material ordering. All seal manufacturer's installation specifications shall be followed by the Contractor for installation of the replacement joint seals.

11.3 MATERIALS

- .1 General
 - a. All materials supplied under this Specification shall be of a type approved by the Contract Administrator and shall be subject to inspection and testing by the Contract Administrator.
 - b. The Contractor shall be responsible for the supply, safe storage and handling of all materials as set forth in this Specification. All materials shall be handled in a careful and workmanlike manner, to the satisfaction of the Contract Administrator.
- .2 Handling and Storage of Materials
 - a. All materials shall be handled and stored in a careful and workmanlike manner, to the satisfaction of the Contract Administrator.
 - b. Store materials under cover in a dry and clean location off the ground.
- .3 Compression Seal
 - a. Preformed compression seals shall be WA-400 Wabo® Compression Seal installed at the locations and in accordance with the details as shown on the Drawings. The seals shall be supplied in one continuous piece. Field welding of the seals shall not be allowed.



- b. The compression seal shall be installed per the manufacturer's requirements.

.4 Strip Seal

- a. The expansion joint seals shall be EFE-400 Wabo® StripSeal, at the locations and in accordance with the details as shown on the Drawings.
- b. Seals shall be supplied in one continuous piece separate from the steel components.
- c. The seals shall be installed as per the manufacturer's requirements.

11.4 CONSTRUCTION METHODS

.1 On-Site Field Dimensions

- a. Prior to commencement of shop drawing preparation and fabrication of expansion joint seals the Contractor shall measure, verify, and document actual field dimensions at the proposed expansion joint installation locations on the bridge. The actual dimensions shall be used for shop drawing detailing and fabrication purposes. The Contractor shall be responsible for ensuring that the expansion joint seals are fabricated to suit actual field dimensions so as to provide for a proper fit without field modification of the expansion joint assemblies.
- b. The Contractor shall be responsible for traffic control during on-site field dimension measurement and verification to ensure that the operation is undertaken in a safe manner. The Contractor will not be allowed to close traffic lanes for these operations and shall use flag persons to temporarily control traffic for these operations. The Contractor shall remove any accumulations of ice, snow and debris on the bridge deck as required for taking accurate on-site field dimensions.

.2 Extrusion Preparation

- a. Abrasive blast clean, surface grind, and air blast the joint recess to remove pack rust, rust scale, mill scale, dirt, laitance, and other foreign and deleterious material prior to installation of the joint seal to allow for proper seal installation.
- b. Remove heavy deposits of oil and grease using solvents.
- c. All bonding surfaces shall be cleaned thoroughly in preparation of receiving new joint seals.

.3 Fabrication

- a. The Contractor shall verify all field dimensions and ensure Shop Drawings are prepared accordingly.
- b. No fabrication shall commence until acceptance of the Shop Drawings from the Contract Administrator have been obtained.

.4 Seal Installation

- a. A permanent seal at each expansion joint unit shall be installed to the satisfaction of the Contract Administrator.
- b. Only upon completion of all concrete cleanup operations shall the Contractor open up the seating areas and prepare them for installation of the seals, as applicable to the site.



- c. The preformed joint seal shall be installed in accordance with the manufacturer's recommendations as one continuous piece after completion of all concrete and asphalt operations, as applicable for each site.
- d. Liberally apply adhesive if specified by the manufacturer to the joint seal and steel joint extrusion. Remove excess adhesive immediately.
- e. Field splicing of joint seals is not permitted. The Contractor shall utilize a moving traffic control zone for installation in a continual seal with no field splices. Traffic control plan for installation of seals shall be approved by the Contract Administrator and shall be completed during low traffic volumes in accordance with Section 3 Traffic Control and Pedestrian Accommodation.
- f. The existing joint cover plates shall be removed and reinstalled. Any damage done by the Contractor to the existing expansion joint components shall be replaced at the Contractor's own expense.

.5 Expansion Joint Water Test

- a. The air, concrete, and expansion joint assembly temperature shall be 2°C or higher at the time of testing.
- b. The joints shall be water tested over one their entire length between curbs, within one-lane at a time. The water test shall be completed when one half of the joint assembly is fully installed and while that same traffic lane of traffic is till closed to vehicles.
- c. Water shall be continuously ponded for a minimum of 1 hour, maintaining a minimum depth of 60 mm above the expansion joint assembly at the curb / gutter lines. The width shall extend 50 mm beyond the concrete end dams on both sides of the expansion joint assembly.
- d. Leakage of water through the expansion joint assembly during the test at any component interface shall constitute failure of the expansion joint assembly. If such a failure occurs, the expansion joint assembly shall be repaired, and the water test repeated. The method of repair shall be submitted in writing by the Contractor to the Contract Administrator for review prior to commencement of repair work. The water test and any related corrective work shall be completed prior to any seasonal shutdowns. Where this is not feasible, a proposal detailing an alternative solution shall be submitted to the Contract Administrator for approval.
- e. The Contractor shall be responsible for providing traffic control during the expansion joint water test. Detailed plans of the Contractor's proposed water testing shall be submitted to the Contract Administrator for review and approval prior to proceeding.
- f. The Contractor shall be responsible for providing access to the Contract Administrator to the joint underside to check for leaking water.

.6 Re-Installation of Expansion Joint Cover Plates

- a. Re-install existing expansion joint cover plates per their original location and configuration. If cutting, drilling, and fitting is required for re-installation of expansion joint cover assemblies, the Contractor shall submit a detailed plan of such activities to the Contract Administrator for review and approval prior to commencing the work.
- b. Install joint cover assemblies in true alignment and proper relationship to the opening of the expansion joint and adjoining finished surfaces.
- c. Allow for thermal expansion and contraction of metal to avoid buckling.



11.5 QUALITY CONTROL

.1 General

- a. All workmanship and all materials furnished and supplied under this Specification are subject to the close and systematic inspection and testing by the Contract Administrator including all operations from the selection and production of materials through to final acceptance of the Work.
- b. The Contractor shall be wholly responsible for the control of all operations incidental thereto notwithstanding any inspection or acceptance that may have been previously given. The Contract Administrator reserves the right to reject any materials or works which are not in accordance with the requirements of this Specification.

.2 Access

- a. The Contractor shall allow the Contract Administrator free access to all parts of the Work at all times. The Contractor shall supply samples to the Contract Administrator or their inspector for testing purposes as required. There will be no charge to the City for samples taken.

.3 Expansion Joint Seal Markings

- a. All expansion joint seals shall be identified as to the Manufacturer by means of a continuous permanent mould mark. The mould marks shall be registered with the Contract Administrator and shall be used on all seals produced by the respective Manufacturer. The seal shall also be permanently marked, on the side of the seal, with the date of production and the batch/lot, at intervals of not more than 1.2 m.
- b. The Contractor shall supply to the Contract Administrator a summary of the seals identifying the date of manufacture, the batch/lot, and the proposed installation location.

.4 Joint Seal Samples and Testing Procedures

- a. All materials failing to meet the Specification requirements will be rejected.
- b. Lots rejected may be culled by the supplier and, upon satisfactory evidence of compliance with the Specifications, will be accepted.
- c. Joint seals shall meet physical Requirements per OPSS 1210.

11.6 MEASUREMENT AND PAYMENT

- .1 Refer to Section 20 Measurement and Payment.

END OF SECTION



SECTION 12 SIGNAGE

12.1 DESCRIPTION

- .1 This Specification shall cover the operations relating to the supply and installation of signage as specified herein.
- .2 The Work to be done by the Contractor under this Specification shall include the furnishing of all superintendence, overhead, labour, materials, equipment, tools, supplies, and all other ancillary items necessary for and incidental to the satisfactory performance and completion of all Work as hereinafter specified.

12.2 SCOPE OF WORK

- .1 The work shall include the supply, fabrication, and installation of signage in accordance with the details shown on the Drawings.
- .2 The Contractor shall submit a complete set of shop drawings of the proposed fabrications and product information for proposed products.

12.3 MATERIAL

- .1 General
 - a. The Contractor shall be responsible for the supply, safe storage, and handling of all materials as set forth in this Specification.
 - b. All materials supplied under this Specification shall be of a type accepted by the Contract Administrator and shall be subject to inspection and testing by the Contract Administrator.
- .2 Bolts, Nuts, and Washers
 - a. Bolts, nuts, and washers shall be in accordance with Ontario Provincial Standard Specification OPSS.PROV 703.
- .3 By-Law Sign (First Avenue Bridge)
 - a. Sign shall be in accordance with Ontario Provincial Standard Specification OPSS.PROV 2001.
 - b. Sign to match By-Law sign on the east side of the bridge.
 - c. Sign shall read: NO SNOWMOBILES PERMITTED FROM EAST END OF CONEY ISLAND THEN NORTHERLY AND WESTERLY TO THE FORMER TOWN LIMITS AND THE SOUTHWEST CORNER OF CONEY ISLAND
 - d. For bidding purposes, the tenderer shall assume the replacement sign to be 900 mm x 900 mm.
- .4 No Wake Sign (First Avenue Bridge)
 - a. Sign shall be in accordance with Ontario Provincial Standard Specification OPSS.PROV 2001.



- b. Sign to match No Wake Sign located on the northeast wingwall.
 - c. Sign shall read: SLOW RIGHT DOWN NO WAKE 9 km.
 - d. For bidding purposes, the tenderer shall assume the replacement sign to be 900 mm x 900 mm.
- .5 Keep Right Sign (Matheson Street Bridge)
- a. Sign shall be in accordance with Ontario Provincial Standard Specification OPSS.PROV 2001.
 - b. Sign shall be RB-25.
 - c. For bidding purposes, the tenderer shall assume the replacement sign to be 300 mm x 900 mm.

12.4 CONSTRUCTION METHODS

- .1 All Materials supplied under this Specification shall be subject to inspection and testing by the Contract Administrator. There shall be no charge to the Owner for any Materials taken by the Contract Administrator for testing purposes.
- .2 Sign installation shall be in accordance with Ontario Provincial Standard Specification OPSS.PROV 703 and as detailed on the Drawings.

12.5 MEASUREMENT AND PAYMENT

- .1 Refer to Section 20 Measurement and Payment.

END OF SECTION



SECTION 13 PAVING STONE SIDEWALK REPAIRS

13.1 DESCRIPTION

- .1 The Specification shall cover the preparation for, and all paving stone sidewalk repairs and related works at the First Avenue Bridge, as specified herein.
- .2 The Work to be done under this Specification shall include the furnishing of all superintendence, overhead, labour, materials, equipment, tools, supplies, and all other ancillary items necessary for and incidental to the satisfactory performance and completion of all work as hereinafter specified.

13.2 SCOPE OF WORK

- .1 This Section shall include loading, transporting, stockpiling, compacting, and testing of noted materials in accordance with this Specification.
- .2 The Work to be done by the Contractor under this Specification shall include all things necessary for and incidental to the satisfactory performance and completion of all Work as hereinafter specified.
- .3 The Work includes:
 - a. Removal of existing paving stones, bedding layer, and base layer.
 - b. Preparation of subgrade.
 - c. Supplying and placing, compacting, and testing granular backfill material.
 - d. Supply and placing levelling sand material.
 - e. Salvage of existing or replacement (in-kind) of damaged paving stones.
 - f. Submit to the Contract Administrator a list of sources and gradations for granular backfill and levelling sand, and Standard Proctor Tests for granular backfill.

13.3 QUALITY CONTROL

- .1 Quality control test frequencies specified as follows are the minimum number required. The Contractor shall perform as many tests as are necessary to ensure that the Work conforms to the requirements of the Contract regardless of the minimum number required.
- .2 The Contractor shall perform density tests on every second lift of the compacted backfill material. The Standard Proctor Density for backfill material shall be determined at the optimum moisture content in accordance with standard laboratory Proctor Compaction Test Procedure. The field density of each backfill layer shall match the applicable Proctor Density, as indicated in this Specification.
 - a. One (1) density test shall be performed for the paving stone repair area.

13.4 MATERIALS

- .1 All Materials supplied under this Specification shall be of type approved by the Contract Administrator and could be subject to additional inspection and testing by the Contract



- Administrator. There shall be no charge to the Owner for any Materials taken by the Contract Administrator for testing purposes.
- .2 The Contractor shall be responsible for the supply, safe storage and handling of all Materials as set forth in this Specification. All Materials shall be handled in a careful and workmanlike manner, to the satisfaction of the Contract Administrator.
 - .3 All Materials supplied under this Specification shall be inspected and tested by the Testing Laboratory designated by the Contractor according to Clause 1.13 Quality Control Testing.
 - .4 All Material shall be accepted by the Contract Administrator at least five (5) Working Days before any construction is undertaken. If, in the opinion of the Contract Administrator, such Materials in whole or in part, do not conform to the Specification detailed herein, or are found to be defective in manufacture, or have become damaged in transit, storage or handling operation, then such Material shall be rejected by the Contract Administrator and replaced by the Contractor at their own expense.
 - .5 Any granular material that does not meet the gradation and/or compaction requirements of this Specification shall be removed and replaced by the Contractor at their own expense, to the satisfaction of the Contract Administrator.
 - .6 Base Layer and Levelling Sand materials shall be free of frozen lumps and shall be placed and compacted in an unfrozen state. Backfill shall not be placed on frozen subsoil. The Contractor shall ensure that the required Compaction densities can be achieved.
 - .7 Base Layer for paving stones at the First Avenue Bridge:
 - a. Base Layer shall consist of Granular A (OPSS.PROV 1010).
 - b. Aggregate properties, quality control, and testing requirements shall adhere to Ontario Provincial Standard Specification OPSS.PROV 314 – Construction Specification for Untreated Granular Subbase, Base, Surface, Shoulder, Selected Subgrade and Stockpiling, and Ontario Provincial Standard Specification OPSS.PROV 1010 – Material Specifications for Aggregates – Base, Subbase, Select Subgrade, and Backfill Material.
 - .8 Bedding Layer for paving stones at the First Avenue Bridge:
 - a. Bedding Layer shall consist of fine sand as approved by the Contract Administrator.

13.5 CONSTRUCTION METHODS

- .1 Site Preparation – First Avenue Bridge
 - a. Remove and salvage paving stones.
 - b. Scrape bedding layer and remove old base layer.
 - c. Compact subgrade prior to the placement of new material.
- .1 Inspection
 - a. Inspection by Contract Administrator of backfill shall be for conformance to Project Specifications.
- .2 Compacted Base Layer



- a. In general, base layer material shall consist of sound, durable particles of gravel, stone, sand and fines, free from sod, roots and organic material, and shall meet the gradation requirements of Part 2 – Products, found in this Specification.
 - b. Do not use frozen material.
 - c. Place Base Layer material in layers not more than 200 mm in loose thickness and compacted to 95% Standard Proctor Dry Density at optimum moisture content.
 - d. The field density of the compacted layers shall be verified by Field Density Tests in accordance with ASTM D6938, or equivalent as accepted by the Contract Administrator.
 - e. The frequency and number of tests to be made shall be as stated in Section 14.3.2. The Contract Administrator shall approve the testing agency selected by the Contractor.
 - f. Holes made by removal of samples from the layer shall be promptly filled by the Contractor with appropriate material and thoroughly compacted so as to conform in every way with the adjoining compacted material.
 - g. Keep large vibratory equipment at least 1.5 m away from structures. Compact this portion using suitable light equipment as accepted by the Contract Administration.
 - h. Base layer shall be placed and compacted in uniform layers until the embankment has been constructed to the specified height as shown on the Drawings.
 - i. In the event that the material is too wet to obtain the specified density, thoroughly work the material by removing and adding dryer product, or other acceptable means, until the optimum moisture content is reached. If the material is too dry add water as necessary. Moisture content of the material being placed in fill areas and embankments shall be controlled to within 3% of the optimum condition.
- .3 Bedding Layer
- a. Place bedding layer material loosely on top of the base layer as noted on the Drawings.
- .4 Place Paving Stones
- a. Reset paving stones to match existing pattern and colour.

13.6 MEASUREMENT AND PAYMENT

- .1 Refer to Section 20 Measurement and Payment.

END OF SECTION



SECTION 14 CLEANING CORRODED STEEL

14.1 DESCRIPTION

- .1 This Specification shall cover all operations relating to the cleaning of corroded steel, as specified herein.
- .2 The work to be done by the Contractor under this Specification shall include the furnishing of all superintendence, overhead, labour, materials, equipment, tools, supplies, and all other ancillary items necessary for and incidental to the satisfactory performance and completion of all Work as hereinafter specified.

14.2 CONSTRUCTION METHODS

- .1 The procedure for cleaning of corroded steel shall be as noted on the Drawings.

14.3 MEASUREMENT AND PAYMENT

- .1 Refer to Section 20 Measurement and Payment.

END OF SECTION



SECTION 15 WALL PACK LIGHT REPLACEMENT

15.1 DESCRIPTION

- .1 This Specification shall cover all operations relating to supply, fabrication, and installation of wall pack lights and light pole replacement, as specified herein.
- .2 The work to be done by the Contractor under this Specification shall include the furnishing of all superintendence, overhead, labour, materials, equipment, tools, supplies, and all other ancillary items necessary for and incidental to the satisfactory performance and completion of all Work as hereinafter specified.

15.2 MATERIALS

- .1 The Contractor shall supply and install a wall pack style light at the north abutment on the Eighth Avenue Bridge. The wall pack light shall be replaced in kind with a model similar to the existing light on the south abutment.

15.3 CONSTRUCTION METHODS

- .1 The Contractor shall obtain any required permits for completing the work involved.
- .2 The Contractor shall have a licensed commercial electrician complete all works for electrical connections in accordance with applicable codes and standards.
- .3 All required wiring, conduits, hardware, and materials shall be supplied by the Contractor in accordance with applicable codes and standards.
- .4 The Contractor shall be required to provide any required access equipment, platforms or scaffolding and traffic control required to facilitate the electrical repair works.

15.4 MEASUREMENT AND PAYMENT

- .1 Refer to Section 20 Measurement and Payment.

END OF SECTION



SECTION 16 WASTE TRANSFER STATION REPAIRS

16.1 DESCRIPTION

- .1 This Specification shall cover the maintenance repairs necessary for the Waste Transfer Station.
- .2 The Work to be done by the Contractor under this Specification shall include the furnishing of all superintendence, overhead, labour, materials, equipment, tools, supplies, and all other ancillary items necessary for and incidental to the satisfactory performance and completion of all work as hereinafter specified.

16.2 MATERIALS

- .1 General
 - a. The Contractor shall be responsible for the supply, safe storage, and handling of all materials set forth in this Specification.
- .2 Handling and Storage of Materials
 - a. All materials shall be handled in a careful and workmanlike manner, to the satisfaction of the Contract Administrator. Storage of materials shall be in accordance with the requirements of CSA Standard CAN3-A23.1, Storage of Materials, latest edition, except as otherwise specified herein.
 - b. The Contractor shall handle and store the steel armouring in a manner that ensures it is not damaged or contaminated with dirt or other materials.
 - c. The steel armouring shall not be placed directly on the ground. Timber pallets or other suitable supports shall be placed under the steel armouring to keep them free from dirt and mud and to provide easy handling.
- .3 Concrete
 - a. Concrete material shall be in accordance with Section 4 Concrete Repairs.
- .4 Armouring
 - a. Steel armouring shall conform to CSA G40.20/G40.21, Grade 300W.

16.3 CONSTRUCTION METHODS

- .1 Concrete Spall and Steel Armouring Repair
 - a. Concrete repair to be completed in accordance with Section 4 Concrete Repairs.
 - b. Steel Armouring to be installed as shown on the Drawings.

16.4 MEASUREMENT AND PAYMENT

- .1 Refer to Section 20 Measurement and Payment.



END OF SECTION



SECTION 17 MISCELLANEOUS MAINTENANCE

17.1 DESCRIPTION

- .1 This Specification shall cover all operations relating to miscellaneous maintenance, as specified herein.
- .2 The work to be done by the Contractor under this Specification shall include the furnishing of all superintendence, overhead, labour, materials, equipment, tools, supplies, and all other ancillary items necessary for and incidental to the satisfactory performance and completion of all Work as hereinafter specified.

17.2 SCOPE OF WORK

- .1 Miscellaneous bolt tightening and bolt replacement at CPR Pedestrian Bridge (two loose connections on joint armouring angle), Eighth Avenue Bridge (three missing hand rail connections), First Avenue Bridge (10 x 1 x 16 mm NC x 40 mm long countersunk bolts on sidewalk coverplate), Parson Street Bridge (one missing bridge railing bolt), Winnipeg River West Branch Bridge (one missing bolt on upper hand railing and tight bolts on mid rail connections at all posts on the south side of the bridge, and replace two newel post bolts, and 12 cover plate counter sunk bolts at an expansion joint), and Portage Bay Walkway Bridge (missing nuts, washers, and bolts on railing connections and missing washer and nut on abutment to arch connection).
- .2 Pressure grout embankment repair at Seventh Avenue Bridge.

17.3 MATERIALS

- .1 Replacement bolts to be of a type approved by the Contract Administrator and shall be in accordance with the Drawings.
- .2 For bidding purposes, tenderers shall assume all bolts are 102 mm long x 22 mm diameter x 40 stainless steel bolts will be required for the Work. The actual bolt sizes, grades, and specifications shall be reviewed with the Contract Administrator on site to confirm specifications prior to the Contractor ordering materials.
- .3 Size, type, and grade of replacement bolts shall match existing and be an in-kind replacement.
- .4 Pressure Grout Repair:
 - a. Grout shall be a mixture of water, Portland Cement, sand, and additives, and have a minimum seven (7) day compressive strength of 3 MPa. The mixture shall be a homogeneous paste with sufficient slump to ensure that all voids are filled to prevent undue stress on the structure.
 - b. Aggregates used for pressure grouting may consist of natural sand, manufactured sand, or a combination of natural and manufactured sand and limestone dust. Maximum particle size shall be 5 mm.
 - c. Type GU normal Portland Cement.



- d. Water shall be clean and free from injurious amounts of oil, acid, alkali, soluble chlorides, organic matter, sediments or other deleterious substances. It shall be equal to potable water in physical and chemical properties.
- e. Add bentonite, or other additives, as required to promote lubrication to ensure complete void filling and to compensate for shrinkage during curing.
- f. The grout plant shall consist of a positive displacement grout injection pump capable of applying variable pressures up to 1,750 kPa (250 psi), and capable of delivering this grout in a uniform and consistent manner. The mixer shall be a high-speed colloidal mixing machine, or equivalent, capable of producing a consistent and homogeneous mixture. The Contractor shall adjust the injection pump pressure to fill all voids and cavities under the slab; however, the top of slab elevation shall not change from existing.
- g. Drilling equipment shall be an electrical drill, coring machine, or other devices capable of drilling grout injection holes through concrete, pavement, and base material.
- h. Provide a quick saw for cutting sidewalks and roadways as needed. It must be available and on site during the pressure grouting operation.

17.4 CONSTRUCTION METHODS

- .1 The Contractor shall replace and install the various bolts for the Work as directed by the Contract Administrator in the field.
- .2 The Contractor shall be responsible for providing all required lubricants for installing / removing bolts, including penetrating oil, and be responsible for drilling out and retapping holes as required.
- .3 Torque amounts applied to bolts shall be as directed by Contract Administrator.
- .4 Pressure Grout Repair:
 - a. Pressure grouting shall not be permitted when the air temperature is 5°C or less, without written approval by the Contract Administrator.
 - b. The open edge of the area to be pressure grouted shall be formed to contain the grout.
 - c. Prior to any pressure grouting, the site shall be inspected by the Contractor and the Contract Administrator. The existing condition of the concrete structure or slab shall be noted, agreed upon, and documented. Should the Contractor deem the site or portion of the site unsuitable for pressure grouting, the Contractor will advise the Contract Administrator.
 - d. Grout injection holes shall be drilled vertically, having a maximum diameter of 50 mm. Drill holes in such a manner as to prevent excessive breakout at the bottom of the slab.
 - e. Pump grout into the holes in a pattern and amount required to fill the void beneath the sidewalk.
 - f. Permanently seal grout holes flush with the surrounding surface with an approved rapid set concrete or other approved patch material. The patch material shall have a minimum thickness of 75 mm.
 - g. Clean-up the site immediately following pressure grouting operations and prior to acceptance. If necessary, use water under pressure as required for clean-up.



- h. Replace any concrete structures and/or asphalt slabs damaged due to unnecessary or excessive force caused by pressure grouting activities.
- i. Restore asphalt and boulevard surfaces after pressure grouting operations, as applicable to the site.

17.5 MEASUREMENT AND PAYMENT

- .1 Refer to Section 20 Measurement and Payment.

END OF SECTION



SECTION 18 UTILITY CONDUIT REPAIR

18.1 DESCRIPTION

- .1 This Specification shall cover all operations relating to the repair of utility conduits at the Winnipeg River East Branch Bridge.
- .2 The work to be done under this Specification shall include the furnishing of all superintendence, overhead, labour, materials equipment, tools, supplies, and all things necessary for and incidental to the satisfactory performance and completion of all work as hereinafter specified.

18.2 MATERIALS

- .1 The Contractor shall supply and install all required materials to complete repairs of exposed, damaged utility conduits at the Winnipeg River East Branch Bridge.
- .2 The conduit repair materials shall be compatible with the existing materials.
- .3 The Contractor shall submit a conduit repair submittal fourteen days in advance of completing the work and be acceptable to the Contract Administrator.

18.3 CONSTRUCTION METHODS

- .1 Conduit repairs shall be completed in line with industry standards and best practices.
- .2 Conduits shall be hand trenched a minimum of 300 mm below grade and backfilled with native material to protect conduits from future damage.

18.4 MEASUREMENT AND PAYMENT

- .1 Refer to Section 20 Measurement and Payment.

END OF SECTION



SECTION 19 GLUED LAMINATED TIMBER REPAIRS

19.1 DESCRIPTION

- .1 This Specification shall cover all operations relating to the repair of glued laminated timber (glulam) separations, delaminations, and section loss on the glulam arches at the Portage Bay Walkway Bridge.
- .2 The work to be done under this Specification shall include the furnishing of all superintendence, overhead, labour, materials equipment, tools, supplies, and all things necessary for and incidental to the satisfactory performance and completion of all work as hereinafter specified.

19.2 MATERIALS

- .1 The Contractor shall supply and install all required materials to complete repairs of the glulam separations, delaminations, and section loss on the glulam arches at the Portage Bay Walkway Bridge.
- .2 The glulam repair materials shall be compatible with the existing materials.
- .3 The Contractor shall submit a glulam repair submittal fourteen days in advance of completing the work and be acceptable to the Contract Administrator.

19.3 CONSTRUCTION METHODS

- .1 Glulam repairs shall be completed in line with industry standards and best practices.

19.4 MEASUREMENT AND PAYMENT

- .1 Refer to Section 20 Measurement and Payment.

END OF SECTION



SECTION 20 MEASUREMENT AND PAYMENT

20.1 GENERAL

- .1 This Section covers the measurement of Work done for payment purposes, and generally covers the scope of the Work included in the various items in the SCHEDULE OF PRICES.
- .2 It is the intention of this contract to provide for a finished piece of Work, complete in all essentials, including all items reasonably inferable from the Contract Drawings and Specifications.
- .3 The aggregate of all unit prices and lump sum payments shall constitute full compensation for the entire Work of the Contract, as shown, specified and intended.
- .4 There shall be no measurement or payment for Work carried out beyond the limits defined on the Contract Drawings or as otherwise approved by Consultant.
- .5 The estimated quantities shown are provided for the purposes of comparing tenders, and they are not guaranteed to be final, accurate or complete. Actual quantities may vary from those initially estimated and will not be grounds for renegotiations of tendered unit prices, except as defined in CCDC 4-2023. The unit prices shall be applicable to greater or lesser quantities. Payment shall be at the unit prices tendered.
- .6 Unless otherwise specified, all materials necessary to complete the items listed in the Schedule of Quantities and Prices and the finished Work are to be new materials supplied by the Contractor and the cost of such material is to be included in the Contractor's prices.
- .7 All measurements for payment purposes shall be taken jointly by the Contractor and The Owner.
- .8 All measurements shall be in the plane of the finished surface unless otherwise indicated.
- .9 Items indicated as provisional, if any, may or may not be included in the final scope of the Work at the sole discretion of the Owner.
- .10 The following shall be considered incidental to the Work:
 - a. Attendance at Consultant Startup Meeting;
 - b. Protection of public;
 - c. Transportation of equipment;
 - d. Transportation of labour to and from the site;
 - e. Coordination and supervision of construction;
 - f. All administration costs, profit and contractual warranty;
 - g. Drawings;
 - h. Labour;



- i. Provision of services;
 - j. Colour and material samples;
 - k. Meetings;
 - l. Regular progress updates and reporting;
 - m. Field measurements and sketches;
 - n. Inspection, quantity survey and measurement assistance for the Consultant;
 - o. Submissions;
 - p. Shop drawings;
 - q. Project record drawings;
 - r. Quality control;
 - s. Cold weather protection and curing of materials;
 - t. Shoring and bracing;
 - u. Temporary works;
 - v. Temporary barriers/barricades;
 - w. Protection, relocation, moving, storing and final location of stored equipment;
 - x. Reinstatement of damaged surfaces; and
 - y. All ancillaries required to complete the Work to the full satisfaction of the Consultant.
- .11 Progress payments for lump sum items shall be approximately equivalent to the percentage of the total Work of the item completed, to the full satisfaction of the Owner, and as described under individual items.

20.2 MOBILIZATION, DEMOBILIZATION, AND SITE WORK

- .1 Measurement for this item is Lump Sum.
- .2 Payment for this item shall be at the lump sum price bid for Item No. 1 in SCHEDULE OF PRICES.
- .3 This item shall include all costs associated with mobilizing and demobilizing from project.
- .4 This item shall include permits and site access, property leasing/rental, site grading, the supply and mobilization of all labour, material, equipment, and other costs associated with the Project, and shall include the demobilization of all equipment and material from the site on completion of the Work as well as all measures necessary to contain and safely dispose of hazardous materials, and to return site to initial (or better) condition.



- .5 This item also includes: Storage of machinery, materials, equipment, accessories and tools appropriate to the job site; supply of the Contractor's site trailer; and all temporary services and connections, such as water, electricity and sanitation.
- .6 This item also includes: provision of all necessary guards, fencing and other security measures to protect the machinery, labour, materials, equipment, tools, access devices and any other installations. Maintenance of traffic lanes adjacent to or under work areas. Inspection of each phase of work. Snow removal from work areas, if required.
- .7 Sixty percent (60%) of the price for Mobilization, Demobilization, and Site Work item shall be considered as relating to mobilization and the balance to demobilization and site work.

A partial payment for mobilization shall be included in the first payment certificate issued for the Contract subject to the Consultant being satisfied that total mobilization has been performed. The payment amount shall be paid in part over a number of payments until totally paid out.

The payment for demobilization shall become due following substantial performance of the Work and subject to the Consultant being satisfied that full demobilization has been performed. The Consultant may, in their discretion, allow partial payment for demobilization before total demobilization has been effected.

- .8 Nothing herein shall be construed to limit or preclude partial payments otherwise provided for by the Contract.
- .9 No deduction will be made, nor will any increase be made, in the lump sum mobilization item regardless of decrease or increase in the final total contract amount or for any other clause.

20.3 SIGNS, TRAFFIC CONTROL, AND MINIMIZING TRAFFIC OBSTRUCTIONS

- .1 Measurement for this item is Lump Sum.
- .2 Payment for this item shall be at the lump sum price bid for Item No. 2 in SCHEDULE OF PRICES.
- .3 This item shall include all traffic control, signs, barricades, concrete barriers, cones, safety nets, safety wires and any other safety measures required that is not provided by The Owner as stated in Section 3.3. The price shall include all jersey and other traffic barriers, traffic drums, and cones, temporary steel plating and fasteners/clamps, signs, traffic control persons, vehicle marking/signage/lights and any other equipment, placement, adjustment, relocation of traffic control devices, temporary pavement markings, material or labour required to ensure full and proper traffic control and the full safety of the travelling public and work crews at all times.
- .4 This item shall also include all navigation signage required by the local authority or by Nav Canada for boat safety and boat traffic during all stages of the work. This shall include costs for signage maintaining and setting up or removing of signage and also include all methods of display for beacons, printed signs etc that may require anchorage to the shore, pier or bridge.
- .5 A maximum of 30% of the Lump Sum price shall be paid on the first progress claim in respect to this item and a maximum of 10% of the Lump Sum price shall be paid on each



subsequent progress claim to a total not exceeding 70%. A minimum of 30% of the Lump Sum price shall be paid on the progress claim following Substantial Performance. Total payment shall not exceed 100% of the Lump Sum price.

20.4 CONSTRUCTION LAYOUT

- .1 Measurement for this item is Lump Sum.
- .2 Payment for this item shall be at the lump sum price bid for Item No. 3 in SCHEDULE OF PRICES.
- .3 This item shall include:
 - a. Precise on-site surveys and measurements of all existing components to prepare the Contractor's Drawings and as built drawings.
 - b. Engineering services on site and at the Contractor's offices for calculations, sketches and drawings.
 - c. Review, validation and/or modification of the design shown on the Contractor's drawings.
 - d. Review, validation and/or required modifications to the engineer's design
- .4 A maximum of 30% of the Lump Sum price shall be paid on the first progress claim in respect to this item and a maximum of 10% of the Lump Sum price shall be paid on each subsequent progress claim to a total not exceeding 70%. A minimum of 30% of the Lump Sum price shall be paid on the progress claim following Substantial Performance. Total payment shall not exceed 100% of the Lump Sum price.

20.5 CONCRETE REPAIRS

- .1 Measurement of this item is per square metre (sq.m).
- .2 Payment for this item shall be at the unit price per sq.m for Item No. 4 in SCHEDULE OF PRICES.
- .3 Payment will not be made for concrete removed past the limits of removal shown on the Drawings. Payment will be made for additional concrete removed if required and approved by the Contract Administrator.
- .4 This item shall include:
 - a. Sounding concrete to determine total repair areas, saw cut and preparation of existing concrete surface and reinforcing steel for repair, supply and installation of formwork, supply and installation of reinforcing steel, supply and installation of anodes, supply and installation of concrete, and all other items incidental to the work.

20.6 ASPHALT REPAIRS

- .1 Measurement of this item is per square metre (sq.m).



- .2 Payment for this item shall be at the unit price per sq.m for Item No. 5 in SCHEDULE OF PRICES.
- .3 This item shall include:
 - a. Sounding asphalt to determine total repair areas, saw cut and removal of existing damaged asphalt and waterproofing membrane, preparation of the surface for repair, supply and installation of new waterproofing membrane, supply and placement of asphalt, and all other items incidental to the work.

20.7 TIMBER PLANKS AND WOOD TREATMENT

- .1 Measurement for this item is Lump Sum.
- .2 Payment for this item shall be at the lump sum price bid for Item No. 6 in SCHEDULE OF PRICES.
- .3 This item shall include:
 - a. All operations for the supply, delivery, and installation of timber planks at the CPR Pedestrian Bridge, as noted on the Drawings, all operations relating to the work necessary for the treatment of wood, and all other items incidental to the work.

20.8 CLEAR VEGETATION FROM EMBANKMENTS

- .1 Measurement for this item is Lump Sum.
- .2 Payment for this item shall be at the lump sum price bid for Item No. 7 in SCHEDULE OF PRICES.
- .3 This item shall include:
 - a. All operations relating to the removal of vegetation on the embankments at the Eighth Avenue Bridge, the First Avenue Bridge, the Matheson Street Bridge, and the Parson Street Bridge, and all items incidental to the work.

20.9 JOINT SEAL REPLACEMENTS

- .1 Measurement of this item is per linear metre (l.m).
- .2 Payment for this item shall be at the unit price per l.m for Item No. 8 in SCHEDULE OF PRICES.
- .3 This item shall include:
 - a. All operations relating to the supply and installation of new joint seals at the First Avenue Bridge and the Seventh Avenue Bridge, and all other items incidental to the work.



20.10 SIGNAGE

- .1 Payment for this item shall be at the unit price per item for Item No. 9 in SCHEDULE OF PRICES.
- .2 This item shall include:
 - a. All operations relating to the supply, fabrication, and installation of signage at the First Avenue Bridge and the Matheson Street Bridge, in accordance with the details shown on the Drawings, and all other items incidental to the work.

20.11 PAVING STONE SIDEWALK REPAIR

- .1 Measurement of this item is per square metre (sq.m).
- .2 Payment for this item shall be at the unit price per sq.m for Item No. 10 in SCHEDULE OF PRICES.
- .3 This item shall include:
 - a. All operations relating to the removal of the existing paving stones, bedding layer and base layer; preparation of subgrade; supply and placement of base layer and bedding sand material; and placement of the existing paving stones in accordance with the Drawings, and all other items incidental to the work.

20.12 CLEANING CORRODED STEEL

- .1 Payment for this item shall be at the lump sum price bid for Item No. 11 in SCHEDULE OF PRICES.
- .2 This item shall include:
 - a. All operations relating to the cleaning of corroded steel in accordance with the Drawings, and all other items incidental to the work.

20.13 WALL PACK LIGHT REPLACEMENT

- .1 Payment for this item shall be at the lump sum price bid for Item No. 12 in SCHEDULE OF PRICES.
- .2 This item shall include:
 - a. All operations relating to supply, fabrication, and installation of wall pack lights and all other items incidental to the work.

20.14 WASTE TRANSFER STATION EDGE ARMOURING

- .1 Measurement of this item is per linear metre (l.m).
- .2 Payment for this item shall be at the unit price per l.m for Item No. 13 in SCHEDULE OF PRICES.



- .3 This item shall include:
 - a. Sounding concrete to determine total repair areas, saw cut and preparation of existing concrete surface and reinforcing steel for repair, supply and installation of formwork, supply and installation of reinforcing steel, supply and installation of anodes, supply and installation of concrete, and all other items incidental to the work.
 - b. All operations relating to the supply and installation of steel armouring within the Waste Transfer Station building, and all items incidental to the work.

20.15 MISCELLANEOUS MAINTENANCE

- .1 Payment for this item shall be at the lump sum price bid for Item No. 14 in SCHEDULE OF PRICES.
- .2 This item shall include:
 - a. All operations relating to miscellaneous bolt tightening, miscellaneous bolt replacement, and pressure grout embankment repair, as noted on the Drawings, and all other items incidental to the Work.

20.16 UTILITY CONDUIT REPAIR

- .1 Payment for this item shall be at the lump sum price bid for Item No. 15 in SCHEDULE OF PRICES.
- .2 This item shall include:
 - a. All operations relating to the repair of utility conduits at the Winnipeg River East Branch Bridge, and all other items incidental to the work.

20.17 GLUED LAMINATED TIMBER REPAIRS

- .1 Payment for this item shall be at the lump sum price bid for Item No. 16 in SCHEDULE OF PRICES.
- .2 This item shall include:
 - a. All operations relating to the repair of glued laminated timber (glulam) on the glulam arches at the Portage Bay Walkway Bridge, and all other items incidental to the work.

20.18 CHARGES BY THE CONSULTANT

- .1 Costs for permits, licenses, and associated costs incurred by the Consultant will be deducted from progress payments. These charges allow the Consultant to recoup any additional costs incurred due to action (or inaction) by the Contractor.

END OF SECTION



Lake of the Woods
KENORA



ISSUED FOR TENDER DRAWINGS

**CITY OF KENORA
Bride Maintenance Repairs
ITT# 312-003-26**

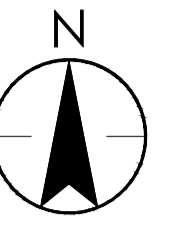

CITY OF KENORA, ONTARIO

BRIDGE MAINTENANCE REPAIRS

- BAY STREET OVERPASS
- CPR PEDESTRIAN BRIDGE
- DARLINGTON BAY BRIDGE
- EIGHTH AVENUE BRIDGE
- FIRST AVENUE BRIDGE
- MATHESON STREET BRIDGE
- PARSON STREET BRIDGE
- SEVENTH AVENUE BRIDGE
- WASTE TRANSFER STATION
- WINNIPEG RIVER EAST BRIDGE
- WINNIPEG RIVER WEST BRIDGE
- PORTAGE BAY WALKWAY BRIDGE



KEY PLAN

May 2026
Project Number: 113733944

DRAWING INDEX

CONSULTANT SHEET No.	SHEET TITLE	SHEET No.
G-001	TITLE PAGE & DRAWING INDEX	1 of 20
G-002	GENERAL NOTES, ABBREVIATIONS, & STANDARD REPAIR DETAILS	2 of 20
S-101	BAY STREET OVERPASS - EXISTING CONDITIONS & REPAIR DETAILS	3 of 20
S-102	CPR PEDESTRIAN BRIDGE - GENERAL ARRANGEMENT	4 of 20
S-103	CPR PEDESTRIAN BRIDGE - EXISTING STAIR FRAMING PLANS & REPAIR DETAILS	5 of 20
S-104	DARLINGTON BAY BRIDGE - EXISTING CONDITIONS & REPAIR DETAILS	6 of 20
S-105	EIGHTH AVENUE BRIDGE - EXISTING CONDITIONS & REPAIR DETAILS - SHEET 1 OF 2	7 of 20
S-106	EIGHTH AVENUE BRIDGE - EXISTING CONDITIONS & REPAIR DETAILS - SHEET 2 OF 2	8 of 20
S-107	FIRST AVENUE BRIDGE - EXISTING CONDITIONS & REPAIR DETAILS - SHEET 1 OF 2	9 of 20
S-108	FIRST AVENUE BRIDGE - EXISTING CONDITIONS & REPAIR DETAILS - SHEET 2 OF 2	10 of 20
S-109	MATHESON STREET BRIDGE - EXISTING CONDITIONS & REPAIR DETAILS - SHEET 1 OF 2	11 of 20
S-110	MATHESON STREET BRIDGE - EXISTING CONDITIONS & REPAIR DETAILS - SHEET 2 OF 2	12 of 20
S-111	PARSON STREET BRIDGE - EXISTING CONDITIONS & REPAIR DETAILS	13 of 20
S-112	SEVENTH AVENUE BRIDGE - EXISTING CONDITIONS & REPAIR DETAILS	14 of 20
S-113	WASTE TRANSFER STATION - ELEVATIONS & SECTION	15 of 20
S-114	WASTE TRANSFER STATION - SECTIONS & DETAILS	16 of 20
S-115	WINNIPEG RIVER EAST BRIDGE - EXISTING CONDITIONS & REPAIR DETAILS	17 of 20
S-116	WINNIPEG RIVER WEST BRIDGE - EXISTING CONDITIONS & REPAIR DETAILS - SHEET 1 OF 2	18 of 20
S-117	WINNIPEG RIVER WEST BRIDGE - EXISTING CONDITIONS & REPAIR DETAILS - SHEET 2 OF 2	19 of 20
S-118	PORTAGE BAY WALKWAY BRIDGE - EXISTING CONDITIONS & REPAIR DETAILS	20 of 20

GENERAL NOTES:

GENERAL CONCRETE REPAIR NOTES:

1. PROVIDE 30 MPa, CLASS C-1 EXPOSURE CONCRETE w/ 10 mm NOMINAL DIAMETER AGGREGATE
2. CONTRACTOR TO SOUND CONCRETE REPAIR AREA TO LOCATE ALL DELAMINATED AREAS AND MARK AREA OFF TO SQUARE OR RECTANGULAR SHAPES. DELAMINATIONS TO BE PROVIDED BY THE CONTRACTOR IN A CONCRETE SOUNDING REPORT.
3. PROVIDE 25 mm DEEP SAWCUT ALONG PERIMETER OF REPAIR AREAS, 25 mm BEYOND THE CLOSEST REINFORCING BAR, WHICH SHALL REMAIN INTACT AND UNCUT. CONTRACTOR TO CONTACT THE CONTRACT ADMINISTRATOR FOR INSPECTION OF THE REINFORCING TO VERIFY CONDITION AFTER SAW CUTTING AND PRIOR TO CONCRETING.
4. FOR REPAIRS, UNDERCUT CONCRETE REPAIR AREA 25 mm BEYOND THE INNERMOST REINFORCING BARS WITH 6kg HAMMER MAX.
5. ABRASIVE BLAST CONCRETE SURFACE AND EXPOSED REINFORCING STEEL TO REMOVE RESIDUAL DUST, DEBRIS, FRACTURED CONCRETE, AND CONTAMINANTS THAT WILL INHIBIT PROPER BONDING.
6. IF ABRASIVE BLASTING IS NOT POSSIBLE, PRESSURE WASH WITH A MINIMUM PRESSURE OF 34 MPa (5000 Psi).
7. CLEAN CONCRETE SURFACE EITHER BY VACUUMING OR BLOWING WITH COMPRESSED AIR.
8. EXISTING SOUND CONCRETE SHALL BE ROUGHENED TO A 6 mm AMPLITUDE.
9. CONTRACTOR SHALL SUPPLY AND PLACE ADDITIONAL REINFORCING STEEL WHEN THE EXISTING REINFORCING STEEL HAS A SECTION LOSS OF 15% OR GREATER AS DETERMINED BY THE CONTRACT ADMINISTRATOR. THE REINFORCEMENT SHALL BE OF THE SAME TYPE AND SIZE AS THE EXISTING AND SPLICED WITH A MINIMUM LAP LENGTH AS DETERMINED BY THE BAR DIAMETERS SHOWN BELOW:

BAR DESCRIPTION	TENSION LAP
10M	400 mm
15M	600 mm
20M	800 mm
25M	1200 mm
30M	1500 mm

REFER TO THE SPECIFICATIONS IF MINIMUM LAP LENGTH CANNOT BE PROVIDED DUE TO THE LOCATION OR CONFIGURATION OF REPAIR

10. IF INSTALLING SACRIFICIAL ANODES FOR CORROSION PROTECTION, REFER TO SACRIFICIAL ANODE NOTES, THEN PROCEED WITH STEP 11. IF NO ANODES ARE BEING INSTALLED, PROCEED DIRECTLY TO STEP 11. BONDING AGENT SHALL BE SIKATOP ARMATEC-110 EPOCEM OR APPROVED EQUAL AND SHALL BE APPLIED TO EXISTING CONCRETE REPAIR SURFACES PRIOR TO CONCRETE PLACEMENT.
11. CONCRETE SURFACE SHALL BE SATURATED SURFACE DRY PRIOR TO APPLICATION OF REPAIR CONCRETE.
12. ANCHOR FORMWORK TO SOUND STRUCTURE AND PRESSURE PUMP OR POUR CONCRETE INTO REPAIR.
13. WHEN PRESSURE PUMPING CONCRETE, PROVIDE PUMP PORTS EVERY 900 mm IN A GRID PATTERN. PUMP STARTING FROM LOWEST POINT. VIBRATE CONCRETE AS REQUIRED TO PREVENT HONEYCOMBING.
14. USE APPROPRIATE CLOTHING, EYE, AND BREATHING PROTECTION AS DIRECTED BY MANUFACTURER REQUIREMENTS. FOLLOW ALL SITE SAFETY REQUIREMENTS AS REQUIRED BY GENERAL CONTRACT AND GOVERNING AUTHORITIES.

GALVANIC ANODE INSTALLATION NOTES

1. NEW REINFORCING STEEL SHALL BE SECURELY FASTENED WITH TIE WIRE TO PROVIDE ELECTRICAL CONTINUITY.
2. ANODES SHALL BE VECTOR XPT GALVANIC ANODE, OR APPROVED EQUAL.
3. ATTACH ANODES TO CLEAN REINFORCING STEEL AND INSTALL ON A GRID PATTERN WITH A MAXIMUM ANODE SPACING OF 500 mm.
4. TEST AND RECORD ELECTRICAL CONTINUITY OF REINFORCING STEEL BEFORE INSTALLATION AND REPAIR AS NECESSARY AS OUTLINED IN THE SPECIFICATIONS. TEST ELECTRICAL CONTINUITY OF ANODE CONNECTION TO REINFORCING STEEL AFTER INSTALLATION. A DC VOLTAGE MEASUREMENT OF ≤ 1 mV CONFIRMS ACCEPTABLE CONTINUITY. RESULTS TO BE LOGGED AND SUBMITTED TO THE CONTRACT ADMINISTRATOR FOR REVIEW AND APPROVAL PRIOR TO CONCRETING.
5. SECURE ANODE WIRES TO REINFORCING STEEL IN ACCORDANCE WITH MANUFACTURER'S INSTRUCTIONS.

STRIP SEAL INSTALLATION NOTES

1. THE ELASTOMERIC GLAND SHOULD BE FIELD INSTALLED IN CONTINUOUS LENGTH SPANNING THE ENTIRE JOINT LENGTH. WABO@PRIMALUB ADHESIVE IS BRUSHED INTO THE FULL PERIMETER OF THE GLAND CAVITY ON THE STEEL EDGE MEMBER PRIOR TO THE ACTUAL GLAND INSTALLATION.

TRAFFIC CONTROL

1. CONTRACTOR SHALL SUPPLY, INSTALL, OPERATE, RELOCATE, MAINTAIN AND REMOVE ALL TRAFFIC CONTROL DEVICES AND PORTABLE TEMPORARY TRAFFIC SIGNALS. THE CONTRACTOR SHALL ALSO PROVIDE FLAGPERSONS AS PART OF THEIR TRAFFIC MANAGEMENT PLAN.
2. THE CONTRACTOR SHALL PREPARE AND SUBMIT A TRAFFIC MANAGEMENT PLAN TO THE CONTRACT ADMINISTRATOR FOR REVIEW AND COMMENT PRIOR TO PROCEEDING WITH ON-SITE TRAFFIC CONTROL.
3. ALL TRAFFIC CONTROL DEVICES (SIGNAGE, CHANNELIZATION DEVICES & BARRICADES), PORTABLE TEMPORARY TRAFFIC SIGNALS, AND FLAGPERSONS SHALL BE IN GENERAL ACCORDANCE AS SHOWN ON THE DRAWINGS AND IN THE SPECIFICATION.
4. AT MOST, ONE LANE CLOSURE WILL BE PERMITTED AT ONE TIME WITH SINGLE LANE ALTERNATING TRAFFIC. NO LANE CLOSURES WILL BE PERMITTED ON LONG WEEKENDS.

ENVIRONMENTAL REGULATIONS

1. THE CONTRACTOR SHALL ENSURE COMPLIANCE ON THEIR PART AND ON THE PART OF THEIR SUBCONTRACTORS WITH THE DEPARTMENT OF FISHERIES AND OCEANS AND CONSERVATION ONTARIO.
2. THE CONTRACTOR AND THEIR SUB CONTRACTORS SHALL ADHERE TO THE CODES, STANDARDS AND REGULATIONS SET FORTH BY THE APPLICABLE REGULATORS.
3. THE CONTRACTOR SHALL SUBMIT AND ENVIRONMENTAL MANAGEMENT PLAN DETAILING LOCATIONS AND METHODS OF SEDIMENT CONTROL, SILT FENCING, MATERIAL CONTAINMENT AND PROPOSED ISOLATION OF ANY INSTREAM WORK.



LIST OF ABBREVIATIONS

@	AT
ALT	ALTERNATE
ALUM	ALUMINIUM
APPROX	APPROXIMATE
AVE	AVENUE
BM	BENCHMARK
BOT	BOTTOM
B/O	BOTTOM OF
BRG	BEARING
BW	BOTH WAYS
@	CENTER LINE
CIP	CAST-IN-PLACE
CJ	CONSTRUCTION JOINT
CLR	CLEAR
CONC	CONCRETE
CONT	CONTINUE
C/W	COMPLETE WITH
CWB	CANADIAN WELDING BUREAU
Ø	DIAMETER
DBL	DOUBLE
DET	DETAIL
DWG	DRAWING
EA	EACH
EC	EDGE OF CURVE
EE	EACH END
EF	EACH FACE
EL	ELEVATION
EQ	EQUAL
EQL SP	EQUAL SPACE
EW	EACH WAY
EXIST	EXISTING
FF	FAR FACE
FIN GR	FINISHED GRADE
G	GIRDER
GALV	GALVANIZED
HORIZ	HORIZONTAL
IB	IRON BAR
IF	INSIDE FACE
LG	LONG
m	METRE
MAX	MAXIMUM
MIN	MINIMUM
MK	MARK
mm	MILLIMETRE
NTS	NOT TO SCALE
No	NUMBER
O/C	ON CENTRE
O/O	OUT TO OUT
OF	OUTSIDE FACE
OPH	OPPOSITE HAND
PL	PLATE
PM	PRIMARY MEMBER
QTY	QUANTITY
R	RADIUS
REINF	REINFORCE
ROW	RIGHT OF WAY
SHT	SHEET
SP	SPACING
SST	STAINLESS STEEL
STD	STANDARD
STR	STRAIGHT
SU	SUBSTRUCTURE UNIT
SYMM	SYMMETRICAL
T&B	TOP & BOTTOM
T/O	TOP OF
THK	THICKNESS
TYP	TYPICAL
UNO	UNLESS NOTED OTHERWISE
U/S	UNDERSIDE
VERT	VERTICAL
WP	WORKING POINT
WV	WITH

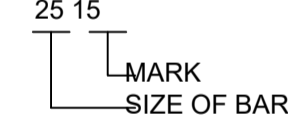
REINFORCING MARK NUMBERING SYSTEM

eg: 25 15

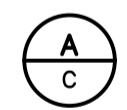
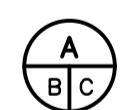
SECTION AND DETAILS

	A SECTION NUMBER OR DETAIL LETTER
	B DRAWING WHERE SECTION OR DETAIL IS TAKEN
	C DRAWING WHERE SECTION OR DETAIL IS DRAWN

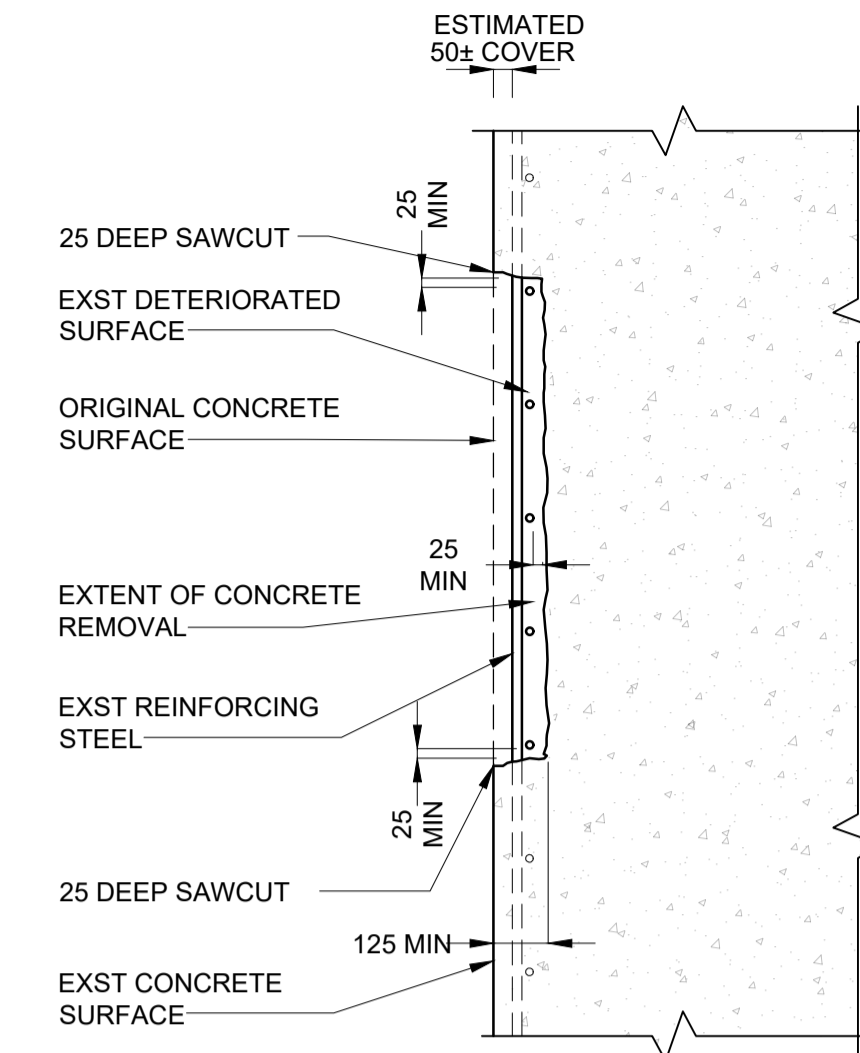
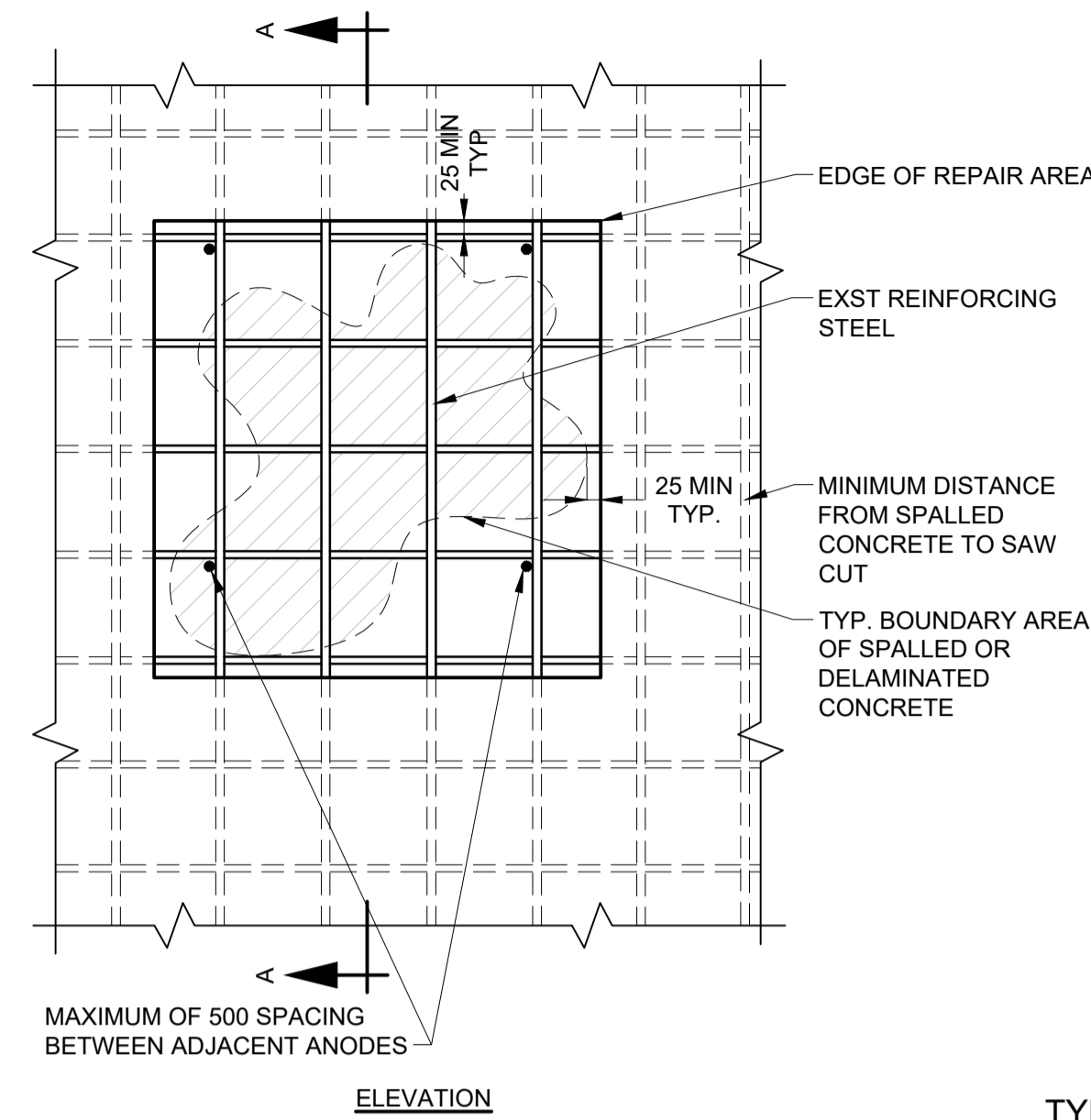

SECTION A-A EXST CONDITION WHERE REBAR IS EXPOSED OR WHERE DEMOLITION EXPOSES REBAR

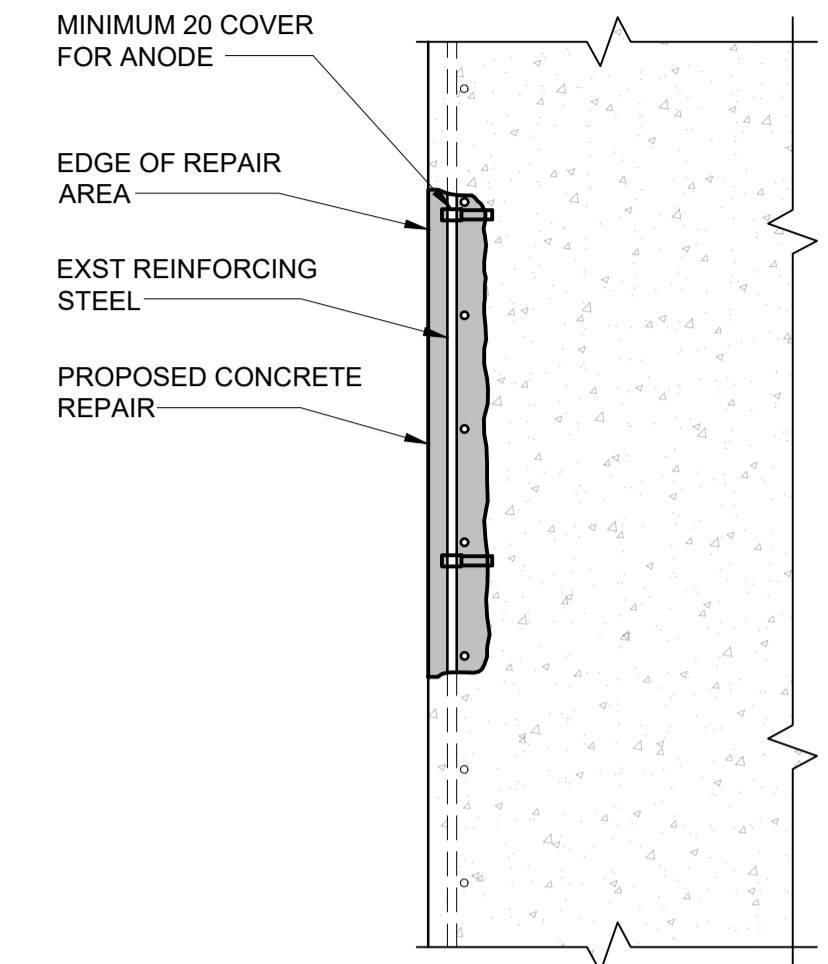

SECTION A-A REPAIRED CONDITION

TYPICAL CONCRETE REPAIR DETAIL

1:20

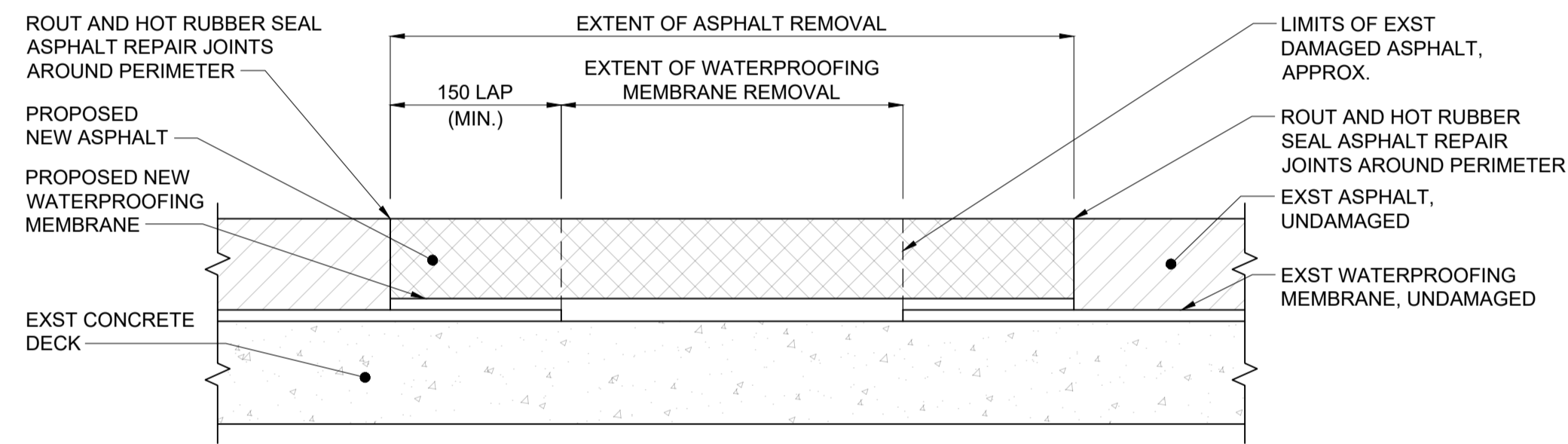

TYPICAL ASPHALT REPAIR DETAIL

1:5

NOTE: PROTECTION BOARD NOT SHOWN WITH

METRIC

WHOLE NUMBERS INDICATE MILLIMETRES
 DECIMALIZED NUMBERS INDICATE METRES

Revision	By	Appd.	YY.MM.DD
5			
4			
3			
2			
1			
E			
D			
C			
B			
A	J.M.B.	E.R.T.	26.05.20
Issued			

Client/Project Logo



Permit/Seal



Stantec Consulting Ltd.
 Suite 500, 311 Portage Avenue
 Winnipeg MB Canada R3B 2B9
 Tel. 204.489.5900 Fax. 204.453.9012
 www.stantec.com

The Contractor shall verify and be responsible for all dimensions.
 DO NOT scale the drawing - any errors or omissions shall be reported to Stantec without delay.
 The Copyrights to all designs and drawings are the property of Stantec.
 Reproduction or use for any purpose other than that authorized by Stantec is forbidden.

Client/Project

CITY OF KENORA, ONTARIO

BRIDGE MAINTENANCE REPAIRS

KENORA, ONTARIO

Title

GENERAL NOTES, ABBREVIATIONS, & STANDARD REPAIR DETAILS

Project No.

Scale

113733944

Drawing No.

Sheet

Revision

G-002

2 of 20

0

File Name:	J.M.B.	T.M.H.	E.R.T.	2026.05.15
33944g-002-4bm.dwg	Dwn.	Chk.	Dgn.	YY.MM.DD

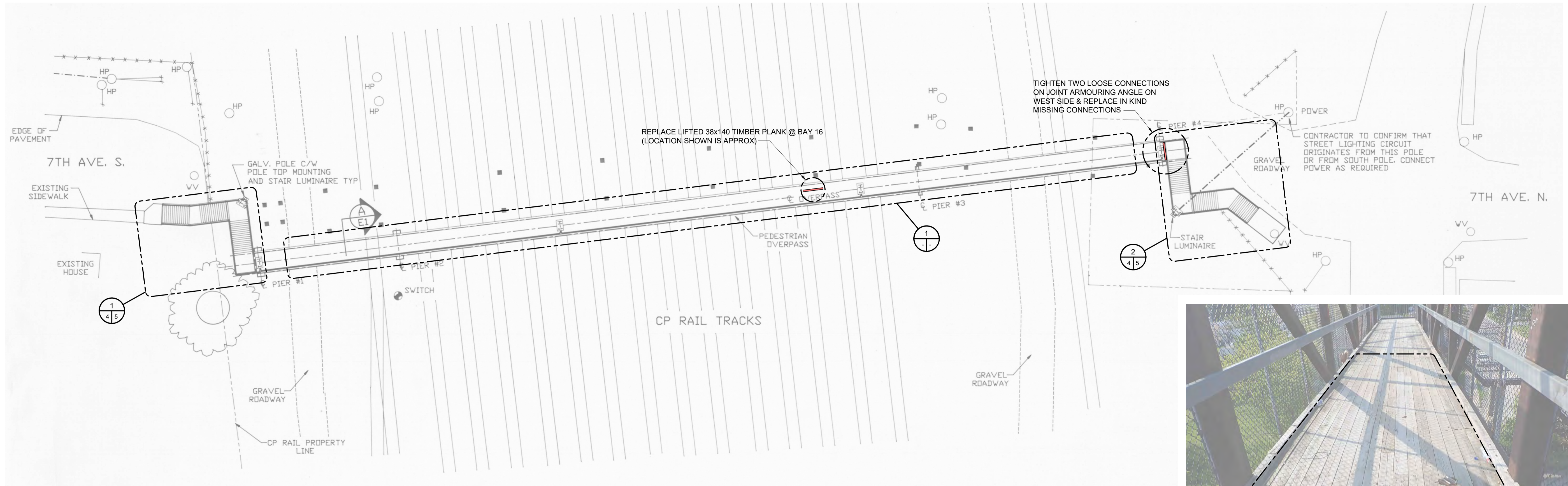
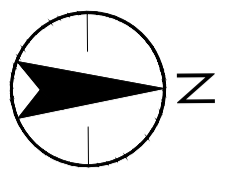

PEDESTRIAN OVERPASS PLAN VIEW
1:250



1 DECK MAINTENANCE DETAIL
NTS

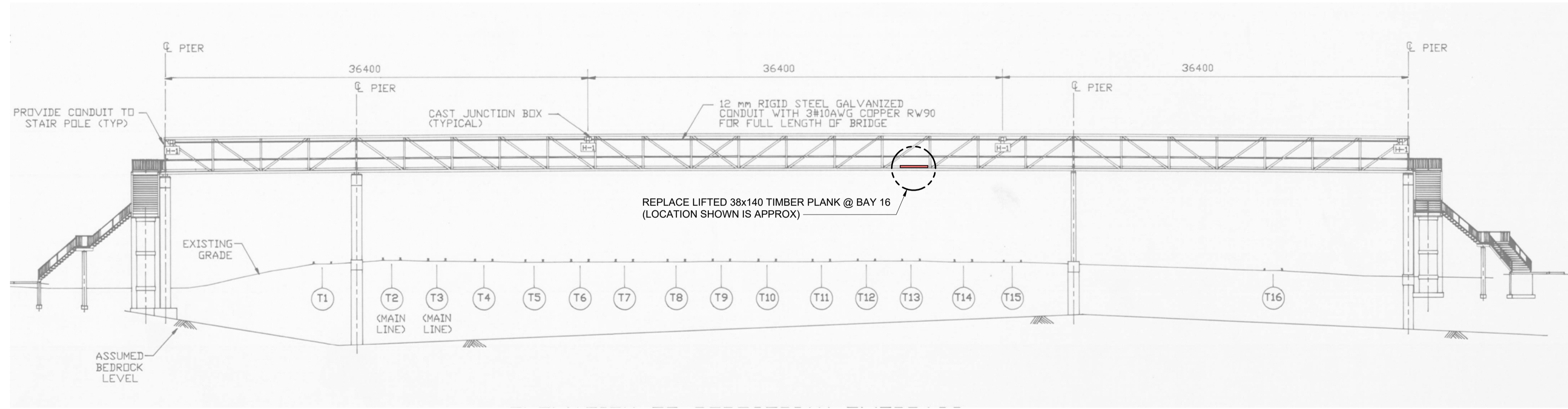

PEDESTRIAN OVERPASS ELEVATION
1:250

- NOTES:**
- SEE SHEET 2 FOR GENERAL NOTES
 - SEE SHEET 2 FOR TYPICAL CONCRETE REPAIR DETAIL
 - SEE SHEET 2 FOR TYPICAL ASPHALT REPAIR DETAIL
- LEGEND**
- EXST POTHOLE IN CONCRETE
 - ▨ EXST EXPOSED REBAR
 - ▤ EXST DELAMINATION APPROX. EXTENTS
 - ▥ EXST CHIP
 - ▧ EXST SPALL
 - ▩ EXST SEVERE SCALING
 - TYPICAL CONCRETE REPAIR APPROX. EXTENT

METRIC
WHOLE NUMBERS INDICATE MILLIMETRES
DECIMALIZED NUMBERS INDICATE METRES

US: 113733944_0000.dwg (Rev. 03/2020) 113733944-0246m.dwg 4-CPR Pedestrian Bridge
 2020/05/20 10:38 AM By: jstewart, James

Revision	By	Appd.	YY.MM.DD
5			
4			
3			
2			
1			
A	J.M.B.	E.R.T.	26.05.20
Issued			

Client/Project Logo

Permit-Seal

Stantec Consulting Ltd.
 Suite 500, 311 Portage Avenue
 Winnipeg MB Canada R3B 2B9
 Tel. 204.489.5900 Fax. 204.453.9012
 www.stantec.com

The Contractor shall verify and be responsible for all dimensions.
 DO NOT scale the drawing - any errors or omissions shall be reported to Stantec without delay.
 The Copyrights to all designs and drawings are the property of Stantec.
 Reproduction or use for any purpose other than that authorized by Stantec is forbidden.

Client/Project
 CITY OF KENORA, ONTARIO

BRIDGE MAINTENANCE REPAIRS

KENORA, ONTARIO

File Name: 33944-10246m.dwg J.M.B. T.M.H. E.R.T. 2026.05.15
 Dwn. Chk. Dgn. YY.MM.DD

Title
 CPR PEDESTRIAN BRIDGE
 GENERAL ARRANGEMENT

Project No. 113733944 Scale AS SHOWN

Drawing No. S-102 Sheet 4 of 20 Revision 0



1 SOUTH STAIR FRAMING PLAN
1:50

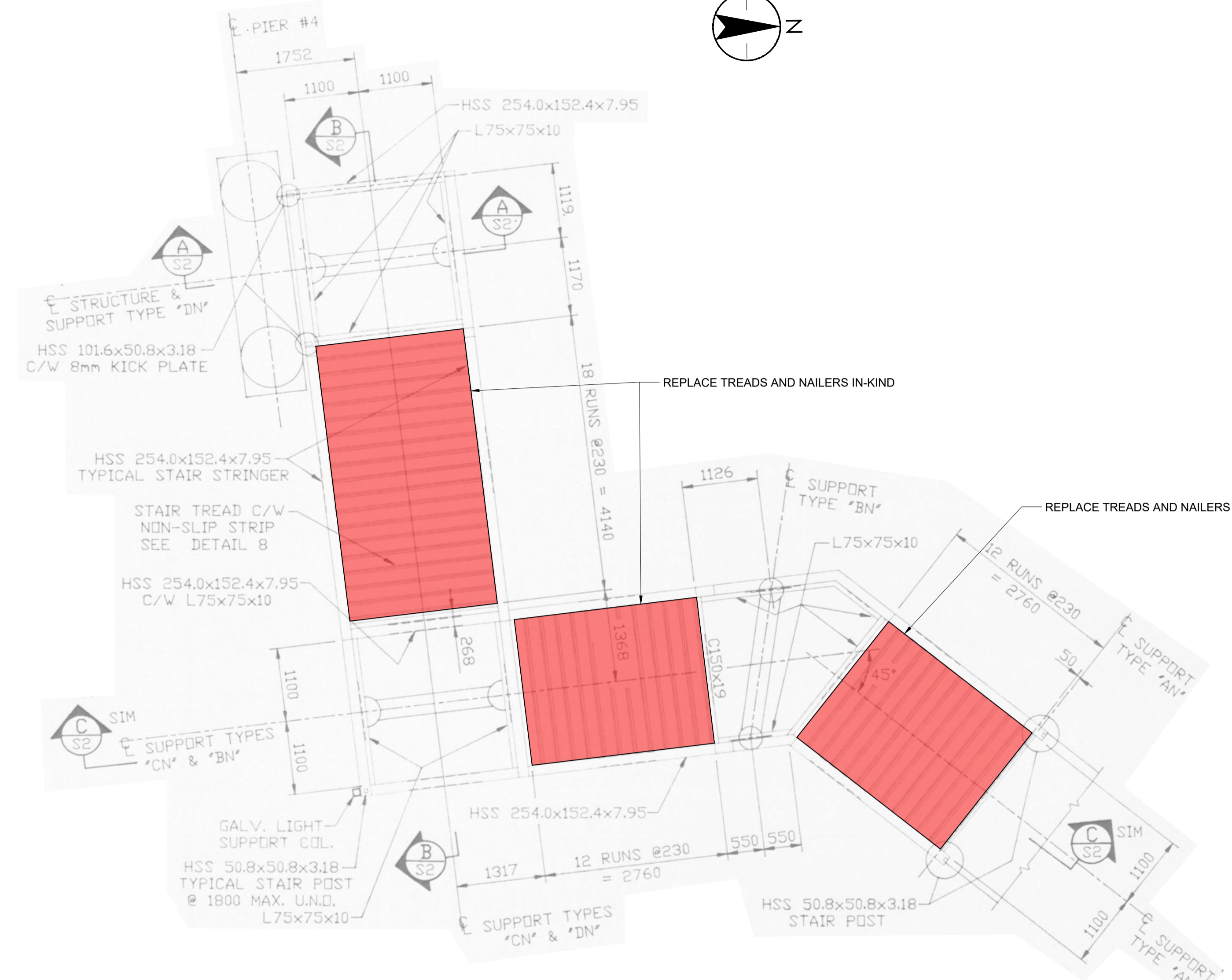

2 NORTH STAIR FRAMING PLAN
1:50

REPAIR NOTES:
FASTENERS USED FOR LUMBER REPAIRS SHALL BE COMPATIBLE WITH THE TYPE OF LUMBER TREATMENT USED.

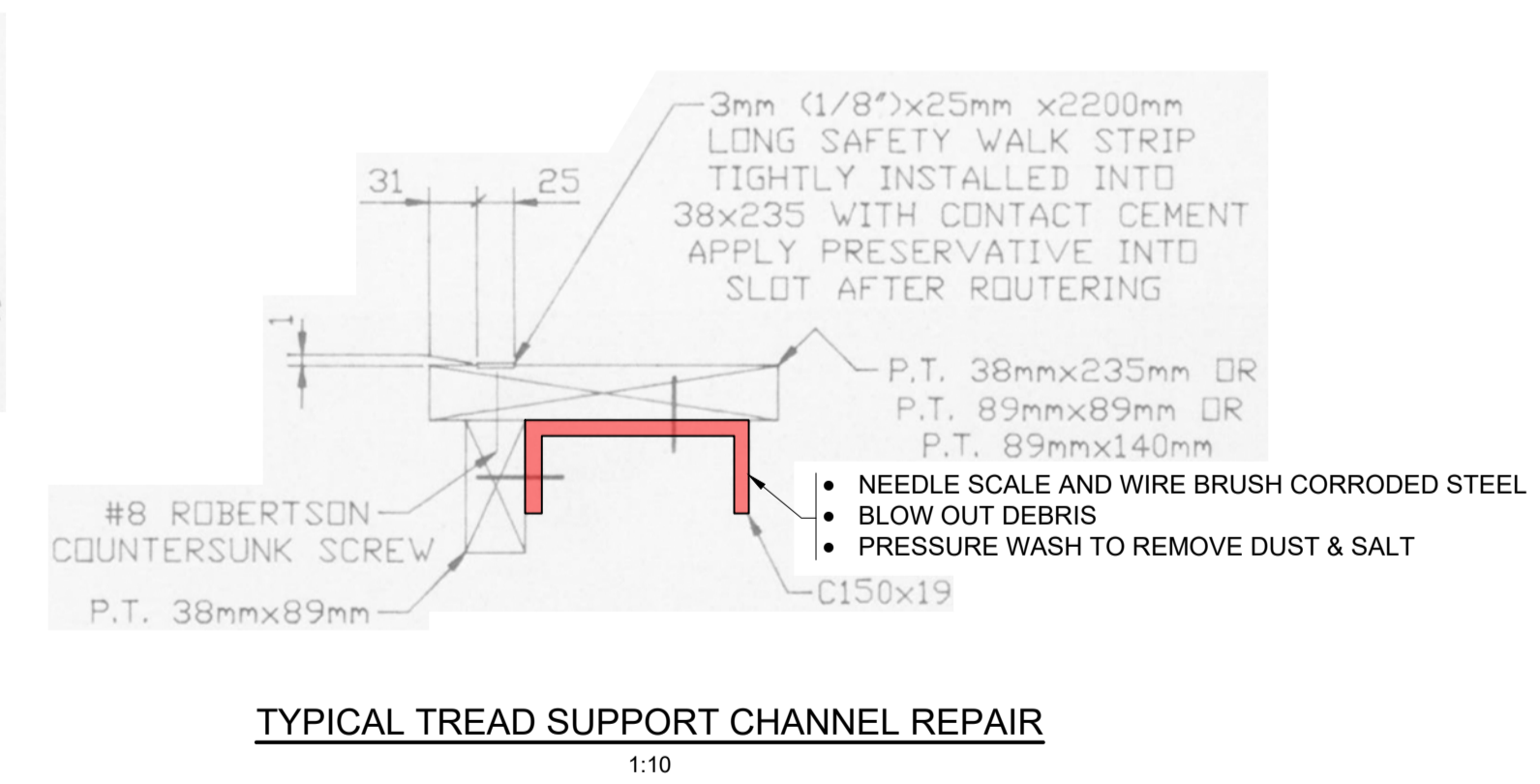
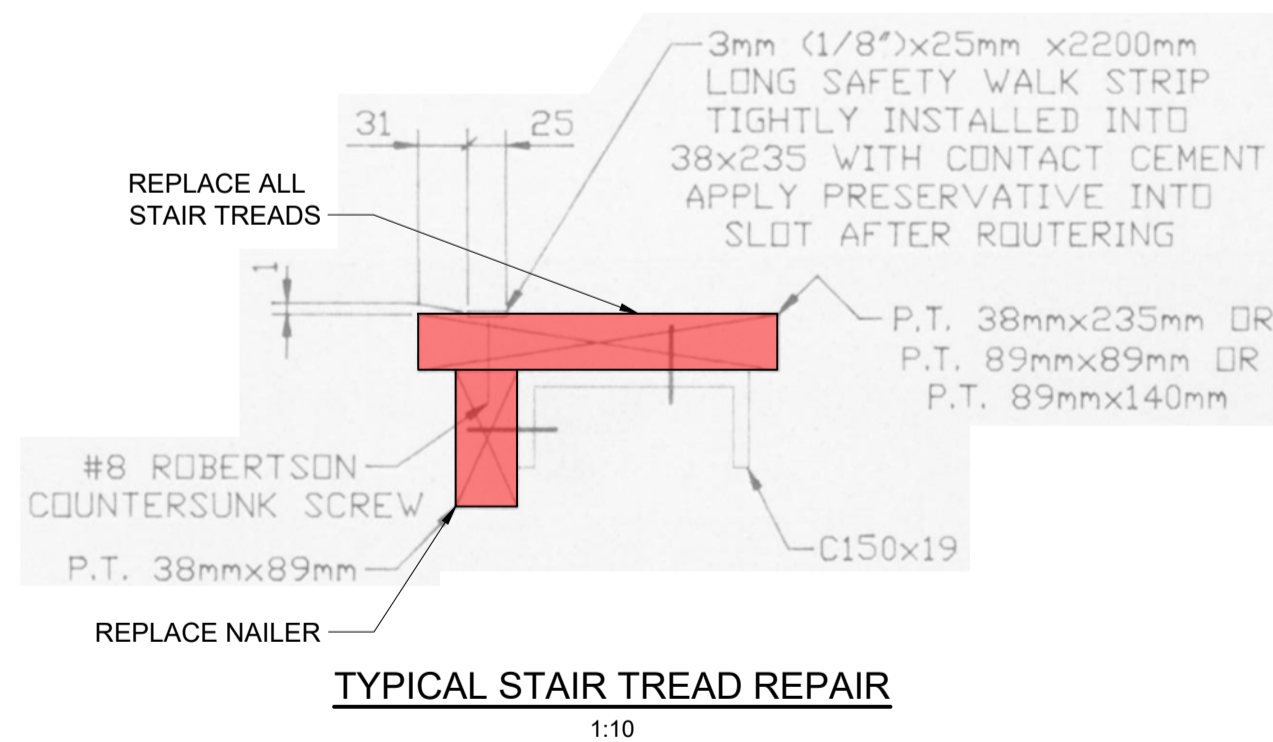

- NOTES:**
SEE SHEET 2 FOR GENERAL NOTES
SEE SHEET 2 FOR TYPICAL CONCRETE REPAIR DETAIL
SEE SHEET 2 FOR TYPICAL ASPHALT REPAIR DETAIL
- LEGEND**
- EXST POTHOLE IN CONCRETE
 - EXST EXPOSED REBAR
 - EXST DELAMINATION APPROX. EXTENTS
 - EXST CHIP
 - EXST SPALL
 - EXST SEVERE SCALING
 - TYPICAL CONCRETE REPAIR APPROX. EXTENT

METRIC
WHOLE NUMBERS INDICATE MILLIMETRES
DECIMALIZED NUMBERS INDICATE METRES

US: 11/20/2014 03:00:00 - Rev: 03 - Structural - 33944 - 024 - 01 - 3 CPR Pedestrian Bridge - 2024/05/20 11:38 AM By: jbermuth, James

Revision	By	Appd.	YY.MM.DD
5			
4			
3			
2			
1			
E			
D			
C			
B			
A	J.M.B.	E.R.T.	26.05.20
Issued			

Client/Project Logo

Permit-Seal

Stantec Consulting Ltd.
Suite 500, 311 Portage Avenue
Winnipeg MB Canada R3B 2B9
Tel. 204.489.5900 Fax. 204.453.9012
www.stantec.com

The Contractor shall verify and be responsible for all dimensions.
DO NOT scale the drawing - any errors or omissions shall be reported to Stantec without delay.
The Copyrights to all designs and drawings are the property of Stantec.
Reproduction or use for any purpose other than that authorized by Stantec is forbidden.

Client/Project
CITY OF KENORA, ONTARIO

BRIDGE MAINTENANCE REPAIRS

KENORA, ONTARIO

File Name: 33944-1024b.dwg
J.M.B. Dwn.
T.M.H. Chk.
E.R.T. Dgn.
2026.05.20

Title
CPR PEDESTRIAN BRIDGE
EXISTING STAIR FRAMING PLANS
& REPAIR DETAILS

Project No. 113733944
Scale AS SHOWN

Drawing No. S-103
Sheet 5 of 20
Revision 0

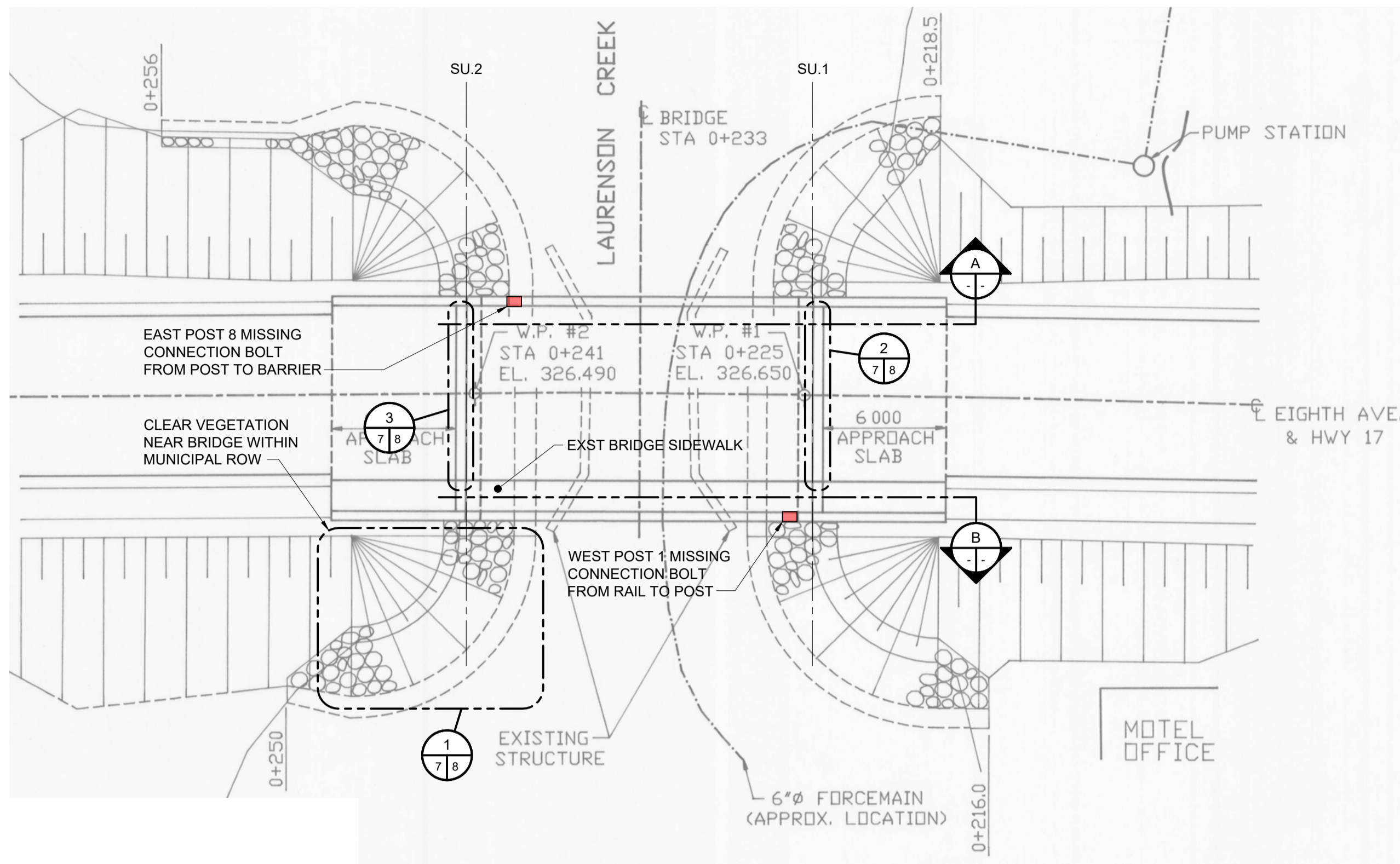

BRIDGE PLAN VIEW
1:200

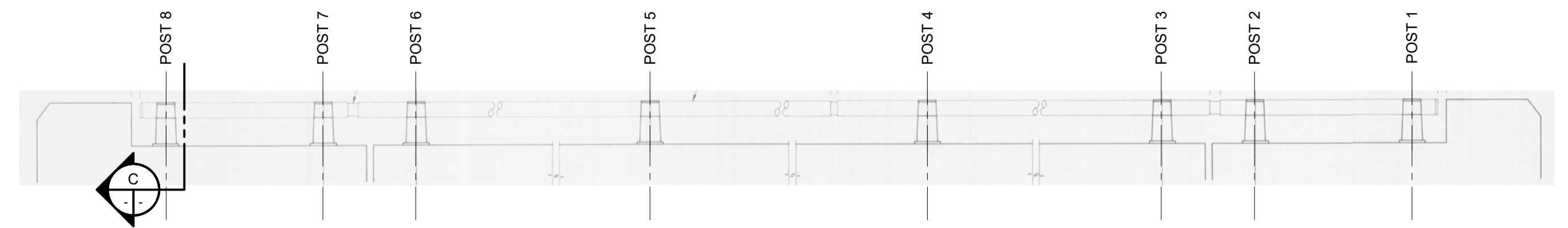
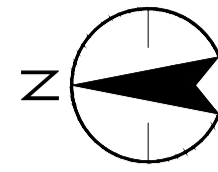

A ELEVATION - GUARDRAIL
NTS

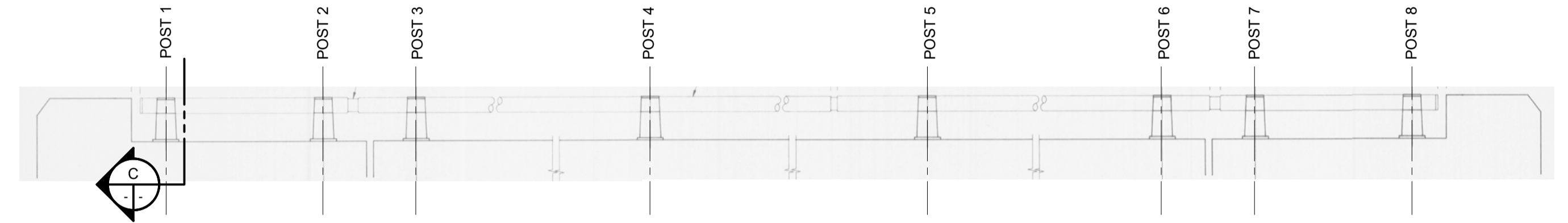

B ELEVATION - GUARDRAIL
NTS

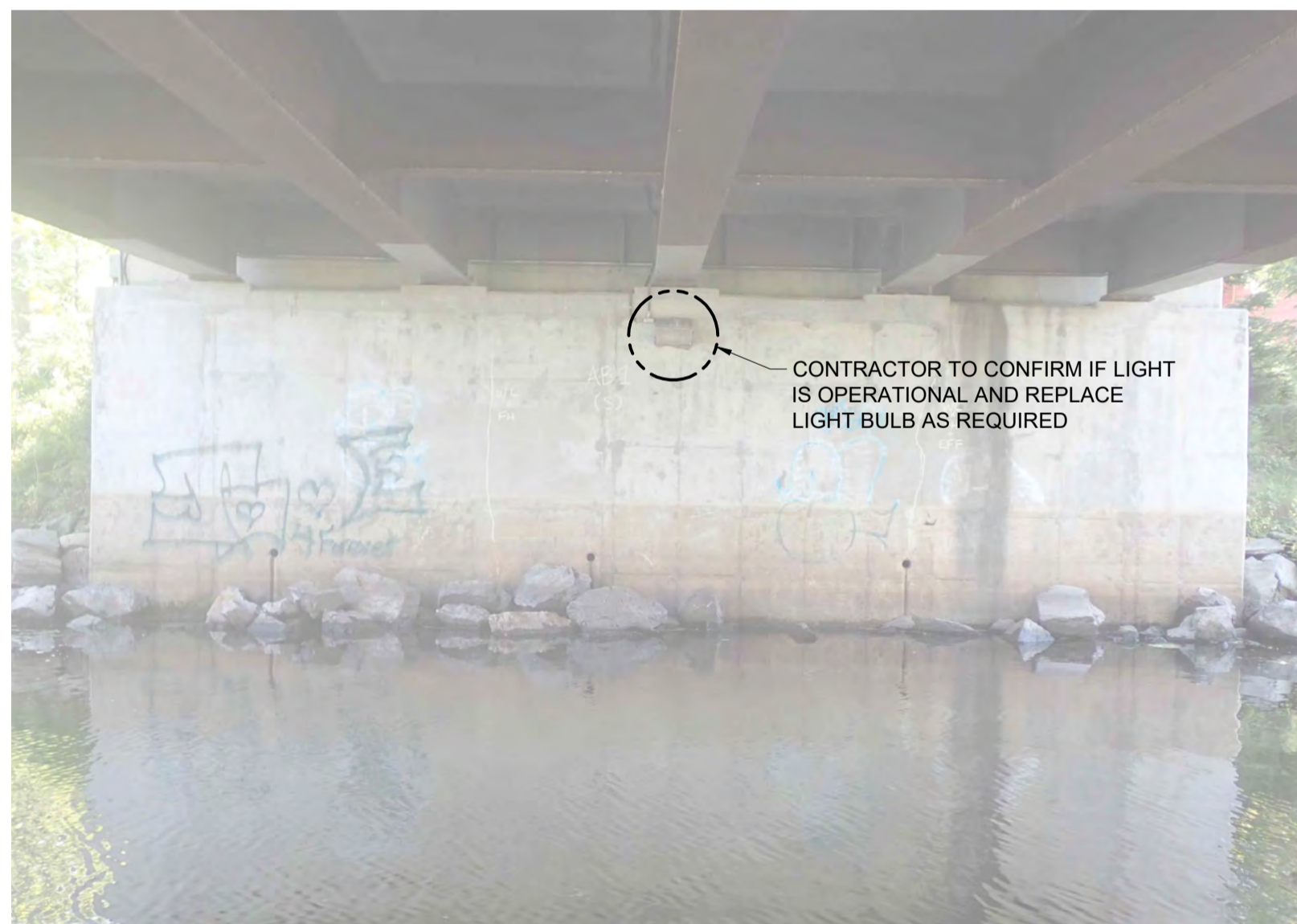

ELEVATION - SOUTH ABUTMENT
NTS



ELEVATION - NORTH ABUTMENT
NTS

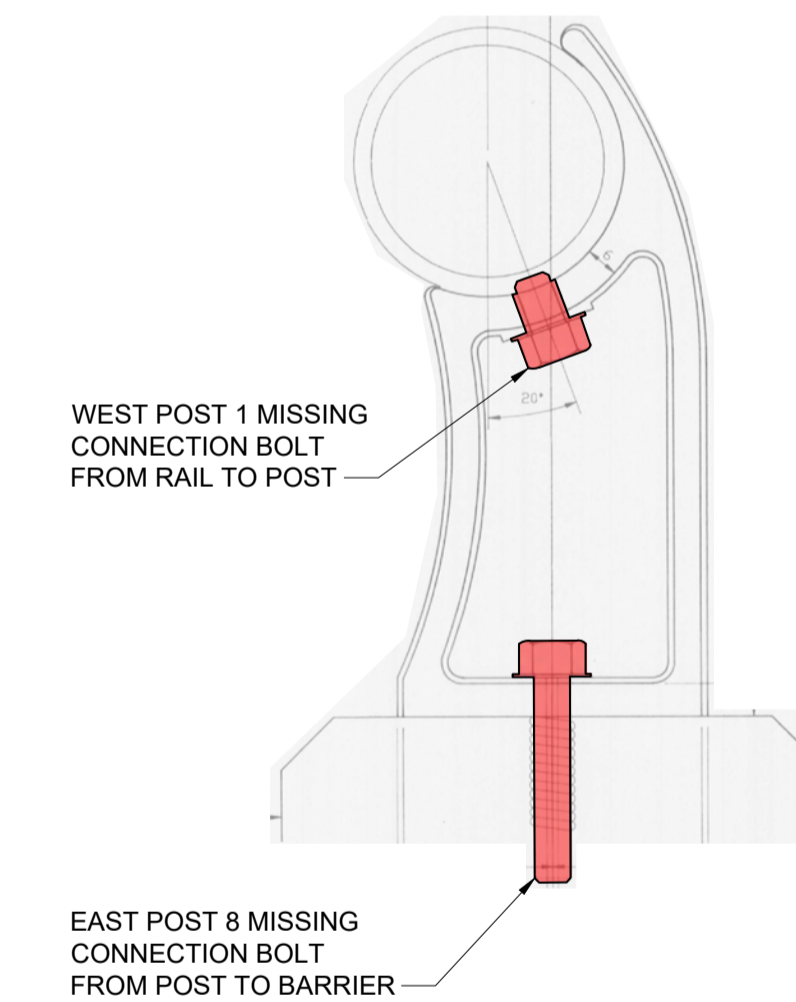

C BARRIER/RAIL MISSING BOLT DETAILS
NTS

- NOTES:**
- SEE SHEET 2 FOR GENERAL NOTES
 - SEE SHEET 2 FOR TYPICAL CONCRETE REPAIR DETAIL
 - SEE SHEET 2 FOR TYPICAL ASPHALT REPAIR DETAIL

- LEGEND**
- EXST POT HOLE IN CONCRETE
 - EXST EXPOSED REBAR
 - EXST DELAMINATION APPROX. EXTENTS
 - EXST CHIP
 - EXST SPALL
 - EXST SEVERE SCALING
 - TYPICAL CONCRETE REPAIR APPROX. EXTENT

METRIC

WHOLE NUMBERS INDICATE MILLIMETRES
DECIMALIZED NUMBERS INDICATE METRES

Revision	By	Appd.	YY.MM.DD
5			
4			
3			
2			
1			
A	J.M.B.	E.R.T.	26.05.20
Issued	By	Appd.	YY.MM.DD

Client/Project Logo



Permit/Seal



Stantec Consulting Ltd.
Suite 500, 311 Portage Avenue
Winnipeg MB Canada R3B 2B9
Tel. 204.489.5900 Fax. 204.453.9012
www.stantec.com

The Contractor shall verify and be responsible for all dimensions.
DO NOT scale the drawing - any errors or omissions shall be reported to Stantec without delay.
The Copyrights to all designs and drawings are the property of Stantec.
Reproduction or use for any purpose other than that authorized by Stantec is forbidden.

Client/Project

CITY OF KENORA, ONTARIO

BRIDGE MAINTENANCE REPAIRS

KENORA, ONTARIO

Title

EIGHTH AVENUE BRIDGE
EXISTING CONDITIONS & REPAIR DETAILS
SHEET 1 OF 2

Project No.	Scale	
113733944	AS SHOWN	
Drawing No.	Sheet	Revision
S-105	7 of 20	0

File Name:	J.M.B.	T.M.H.	E.R.T.	2026.05.15
33944-105-46m.dwg	Dwn.	Chkt.	Dgn.	YY.MM.DD

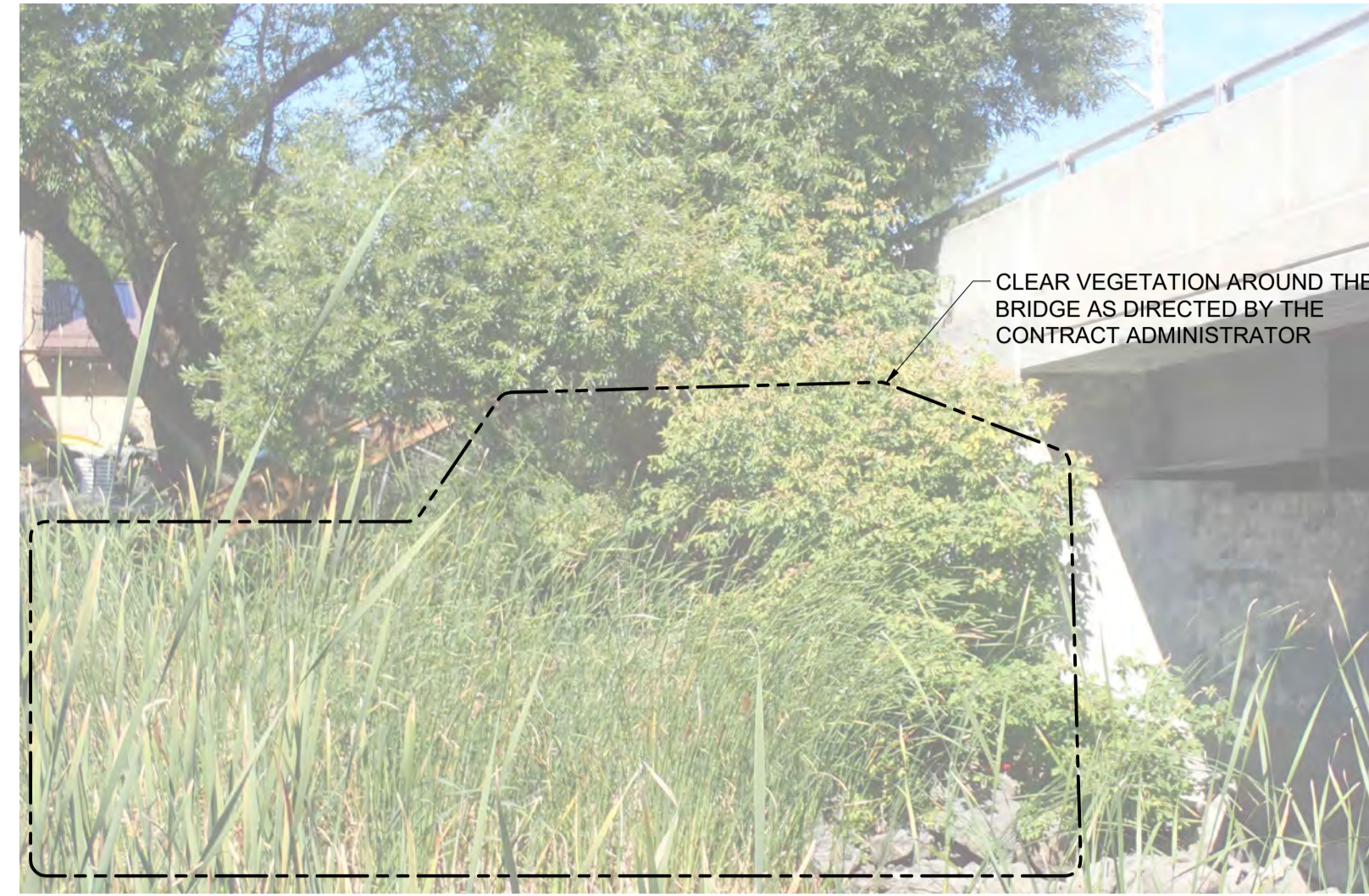

1
7/8
JOINT 1 - VEGETATION CLEARING
NTS

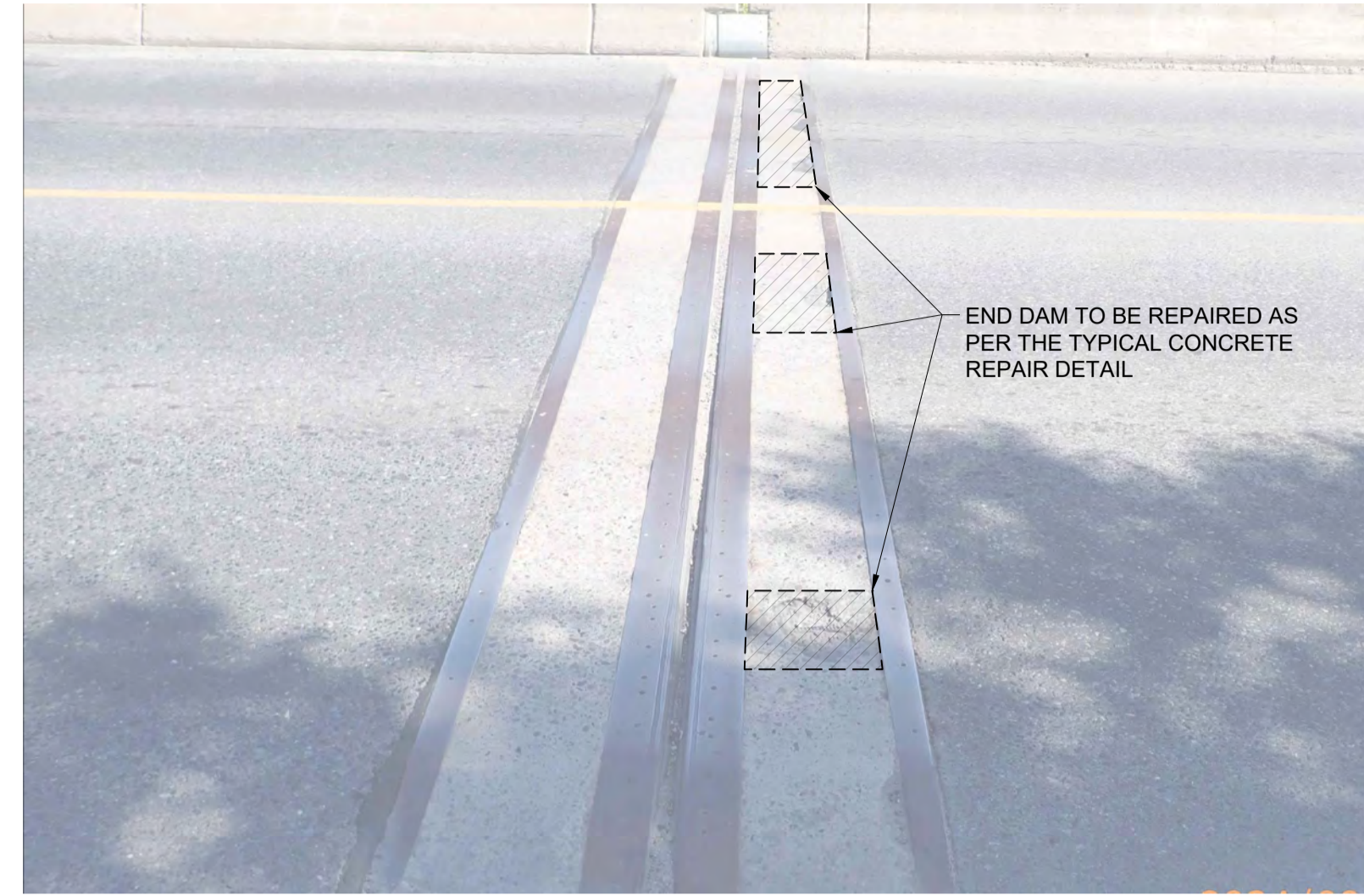

2
7/8
JOINT 1 - CONCRETE END DAM SPALL
NTS

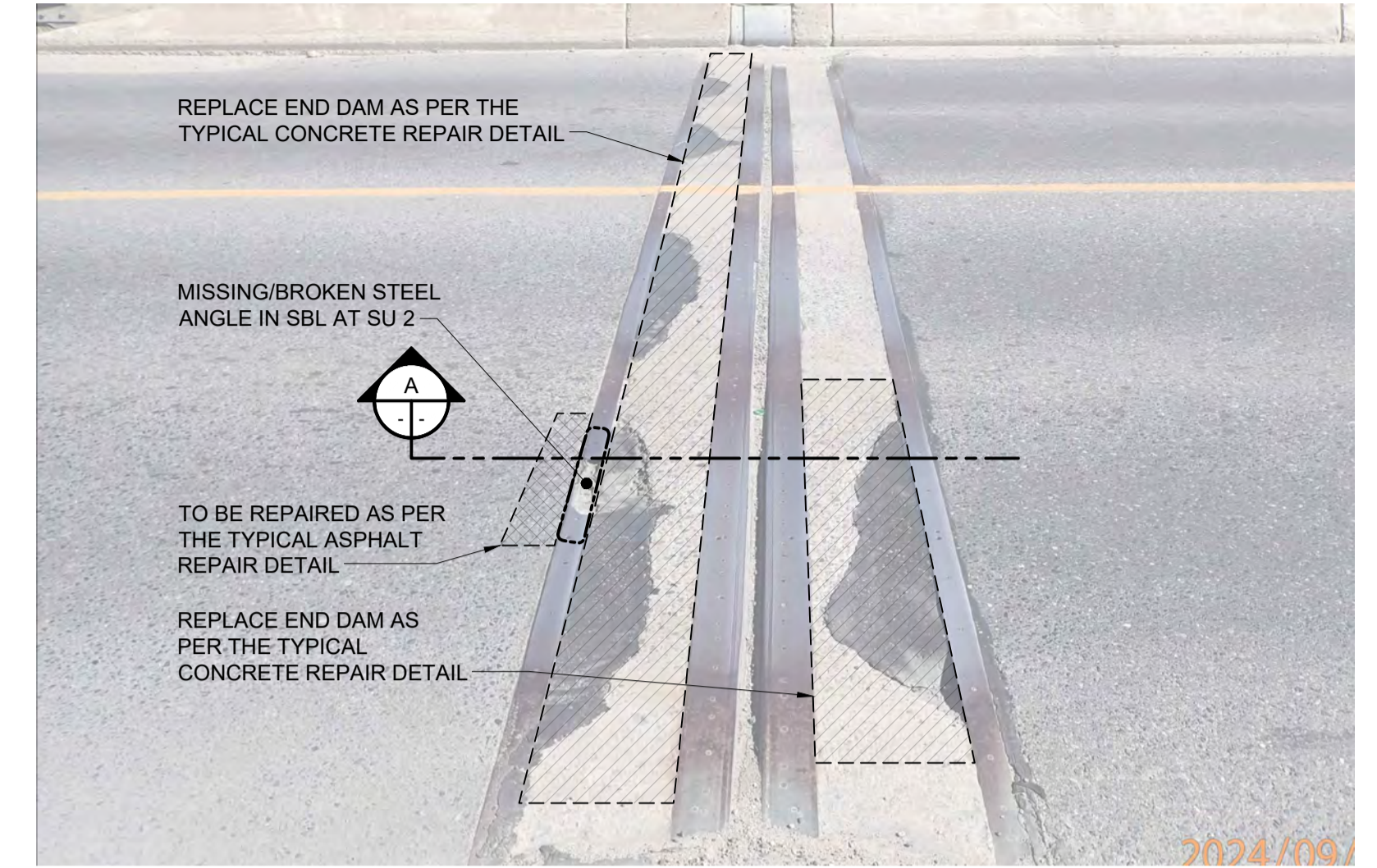

3
7/8
JOINT 2 - MISSING STEEL PLATE AND CONCRETE END DAM SPALL
NTS

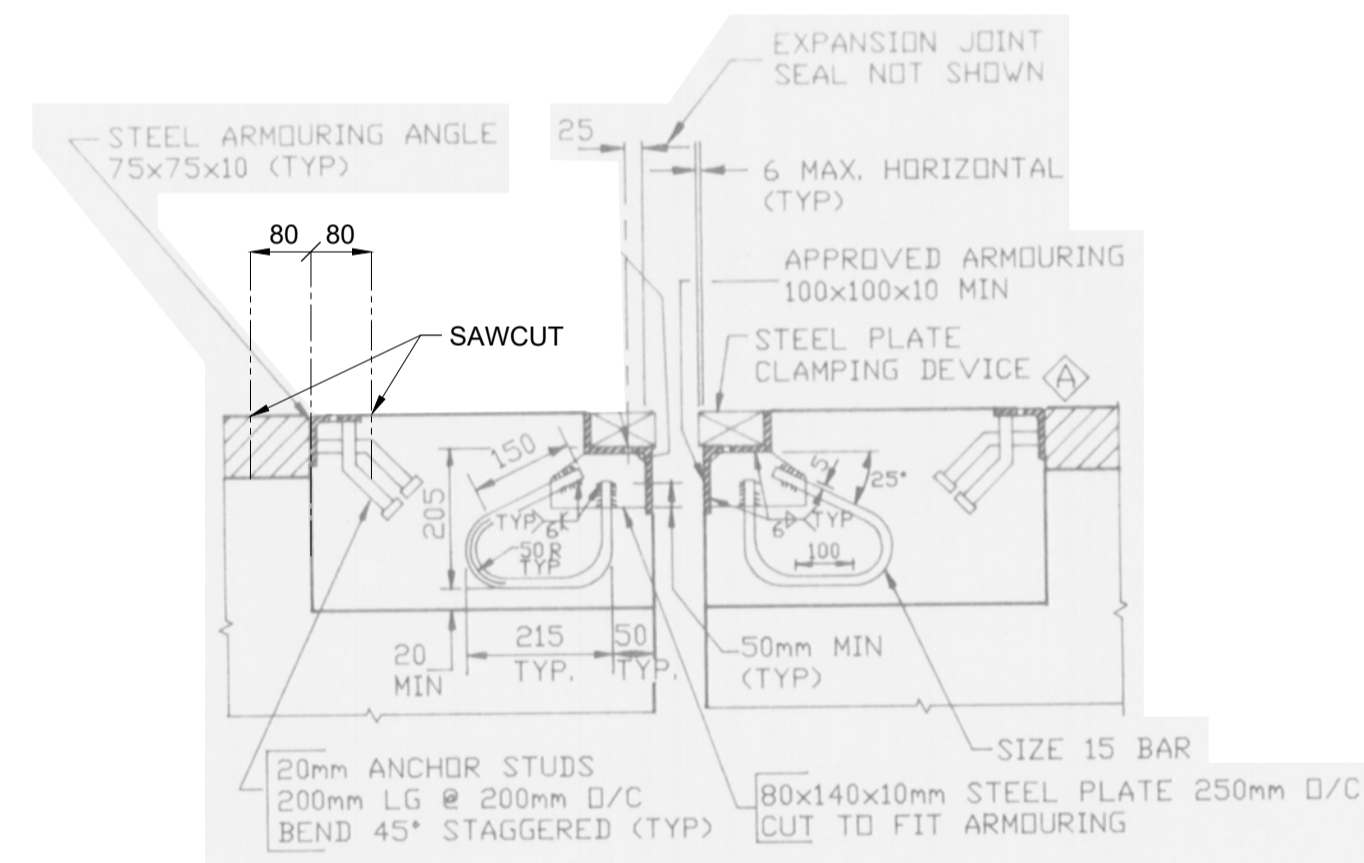

REPAIR NOTES:

1. SAW CUT TO REMOVE EXISTING BROKEN ANGLE AS SHOWN IN THE DETAIL ABOVE AND EXPOSE ANCHOR STUDS ARE TO BE CUT DOWN AND REMOVED AS POSSIBLE.
2. REMOVE 80MM OF ASPHALT AND 80MM OF CONCRETE ADJACENT TO EACH SIDE OF STEEL ANGLE.
3. REPLACE ANGLE SECTION IN-KIND WITH NEW WELDED ANCHORS AS REQUIRED. WEARING SURFACE OF ANGLE TO BE GROUND FLUSH WITH EXISTING STEEL.
4. REFER TO CONCRETE AND ASPHALT REPAIR DETAIL TO REPAIR CONCRETE ADJACENT TO STEEL ANGLE.

A
NTS
ARMOUR REPAIR DETAIL

NOTES:

- SEE SHEET 2 FOR GENERAL NOTES
- SEE SHEET 2 FOR TYPICAL CONCRETE REPAIR DETAIL
- SEE SHEET 2 FOR TYPICAL ASPHALT REPAIR DETAIL

LEGEND

- EXST POTHOLE IN CONCRETE
- EXST EXPOSED REBAR
- EXST DELAMINATION APPROX. EXTENTS
- EXST CHIP
- EXST SPALL
- EXST SEVERE SCALING
- TYPICAL CONCRETE REPAIR APPROX. EXTENT

METRIC

WHOLE NUMBERS INDICATE MILLIMETRES
DECIMALIZED NUMBERS INDICATE METRES

US: 13133944-0000.dwg; 03/20/2024 11:51 AM By: jbenmorrish, James

Revision	By	Appd.	YY.MM.DD
5			
4			
3			
2			
1			
A	J.M.B.	E.R.T.	26.05.20
Issued			

Client/Project Logo



Permit-Seal



Stantec Consulting Ltd.
Suite 500, 311 Portage Avenue
Winnipeg MB Canada R3B 2B9
Tel. 204.489.5900 Fax. 204.453.9012
www.stantec.com

The Contractor shall verify and be responsible for all dimensions.
DO NOT scale the drawing - any errors or omissions shall be reported to Stantec without delay.
The Copyrights to all designs and drawings are the property of Stantec.
Reproduction or use for any purpose other than that authorized by Stantec is forbidden.

Client/Project

CITY OF KENORA, ONTARIO

BRIDGE MAINTENANCE REPAIRS

KENORA, ONTARIO

File Name: 33944-105-4b.m.dwg J.M.B. T.M.H. E.R.T. 2026.05.20
Dwn. Chkt. Dign. YY.MM.DD

Title

EIGHTH AVENUE BRIDGE
EXISTING CONDITIONS & REPAIR DETAILS
SHEET 2 OF 2

Project No. 113733944 Scale AS SHOWN

Drawing No. S-106 Sheet 8 of 20 Revision 0



REPAIR 0.4x0.4 POTHOLE AS PER THE TYPICAL ASPHALT CONCRETE REPAIR DETAIL IN ASPHALT



1 NORTHBOUND LANE - DECK DAMAGE DETAIL
11 12 NTS



REPAIR APPROACH DELAMINATION AND POTHOLE IN ASPHALT AS PER THE TYPICAL ASPHALT CONCRETE & ASPHALT REPAIR DETAILS

2 NORTHBOUND LANE - APPROACH DAMAGE DETAIL
11 12 NTS

NOTES:
SEE SHEET 2 FOR GENERAL NOTES
SEE SHEET 2 FOR TYPICAL CONCRETE REPAIR DETAIL
SEE SHEET 2 FOR TYPICAL ASPHALT REPAIR DETAIL

- LEGEND**
-  EXST POTHOLE IN CONCRETE
 -  EXST EXPOSED REBAR
 -  EXST DELAMINATION APPROX. EXTENTS
 -  EXST CHIP
 -  EXST SPALL
 -  EXST SEVERE SCALING
 -  TYPICAL CONCRETE REPAIR APPROX. EXTENT

METRIC

WHOLE NUMBERS INDICATE MILLIMETRES
DECIMALIZED NUMBERS INDICATE METRES

Revision	By	Appd.	YY.MM.DD
5			
4			
3			
2			
1			
A	J.M.B.	E.R.T.	26.05.20
Issued	By	Appd.	YY.MM.DD

Client/Project Logo



Permit-Seal



Stantec Consulting Ltd.
Suite 500, 311 Portage Avenue
Winnipeg MB Canada R3B 2B9
Tel. 204.489.5900 Fax. 204.453.9012
www.stantec.com

The Contractor shall verify and be responsible for all dimensions.
DO NOT scale the drawing - any errors or omissions shall be reported to Stantec without delay.
The Copyrights to all designs and drawings are the property of Stantec.
Reproduction or use for any purpose other than that authorized by Stantec is forbidden.

Client/Project
CITY OF KENORA, ONTARIO

BRIDGE MAINTENANCE REPAIRS

KENORA, ONTARIO

File Name: 33944e-109-46m.dwg
J.M.B. Dwn.
T.M.H. Chkt.
E.R.T. Dign.
2026.05.15
YY.MM.DD

Title
MATHESON STREET BRIDGE
EXISTING CONDITIONS & REPAIR DETAILS
SHEET 2 OF 2

Project No. 113733944
Scale AS SHOWN

Drawing No. S-110
Sheet 12 of 20
Revision 0

US: 113733944_0000_01.dwg; 03/20/2026 10:00 AM; User: J.M.B.; Plot: 113733944-109-46m.dwg; 12 Matheson Street Bridge
 2026/05/20 12:12 PM By: steemacn, James

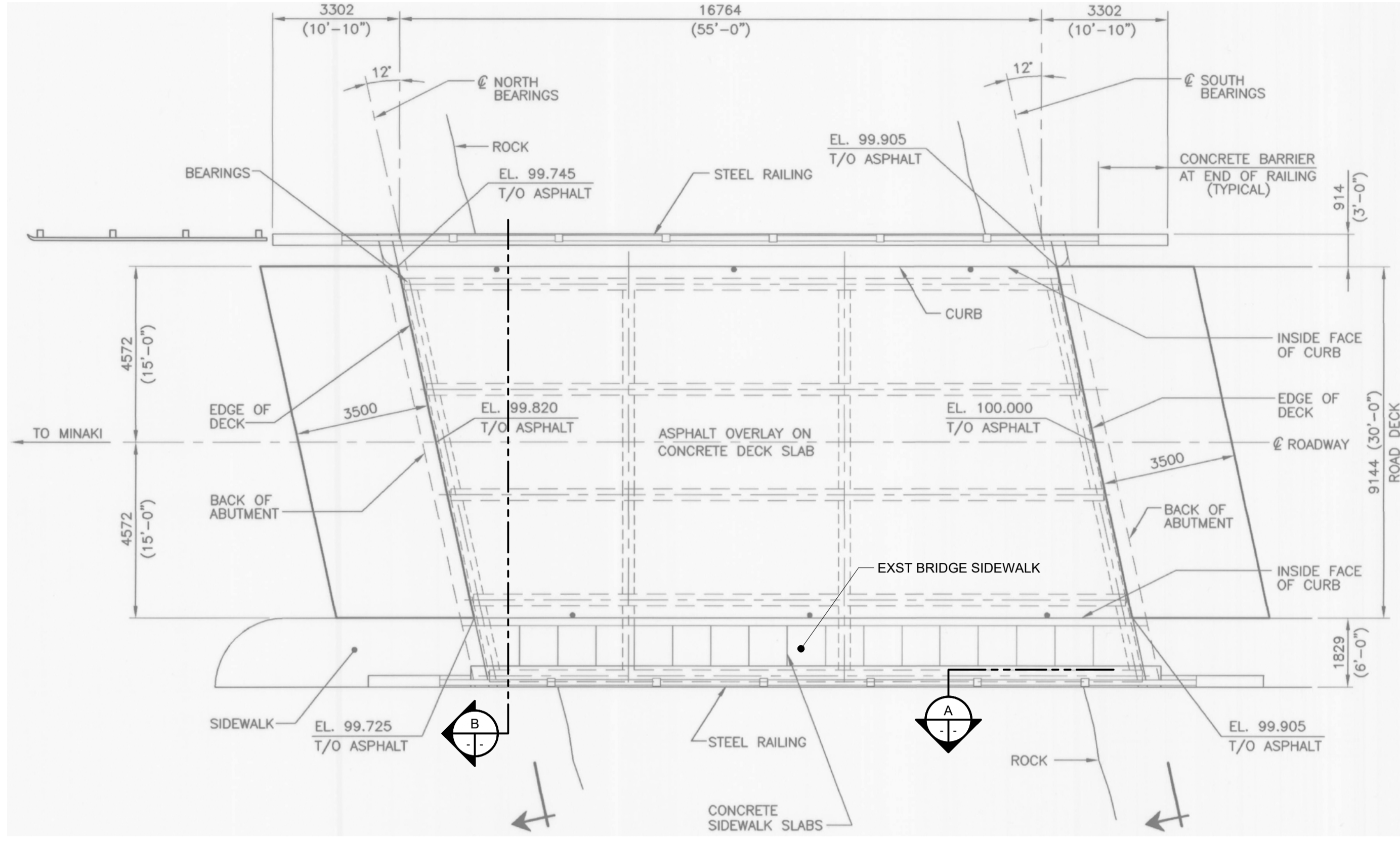
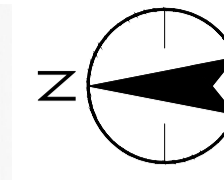

BRIDGE PLAN VIEW
1:100

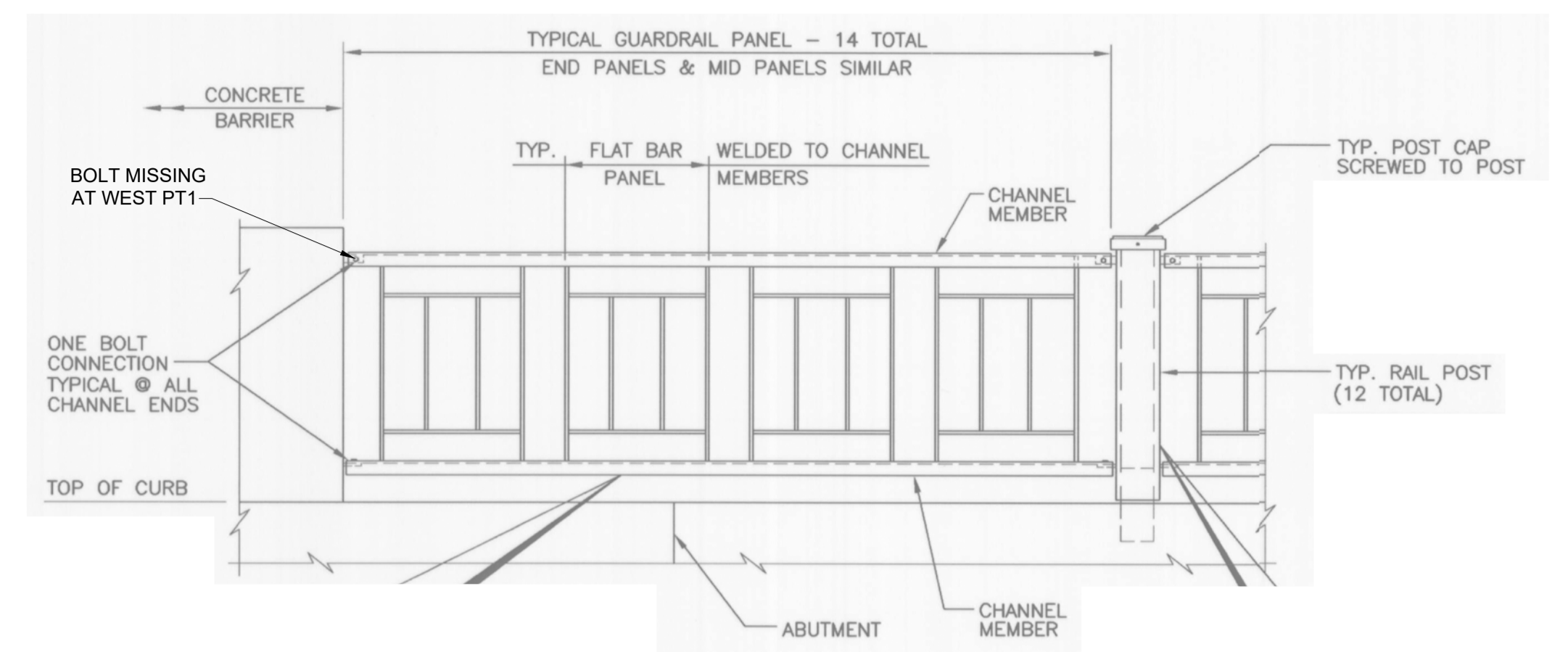

A - GUARDRAIL SECTION
1:50

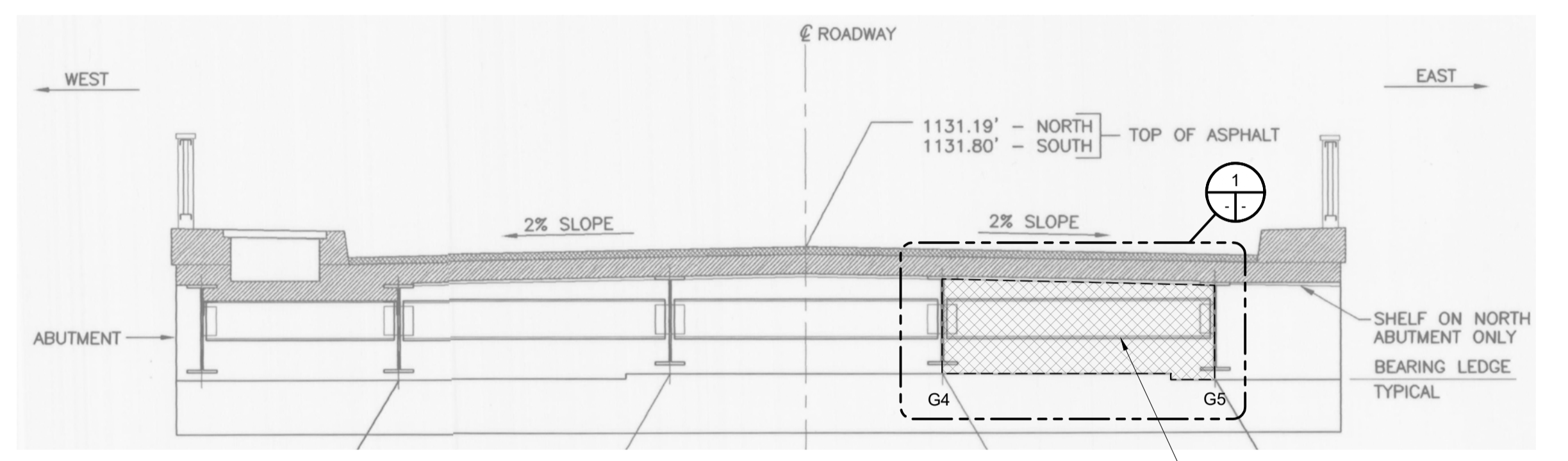

B - NORTH ABUTMENT - BALLAST WALL SECTION
1:50

TEMPORARY REMOVAL/RELOCATION OF DIAPHRAGM TO PERMIT CONCRETE REPAIR WORKS MAY BE PERMITTED FOLLOWING REVIEW AND APPROVAL BY CONTRACT ADMINISTRATOR

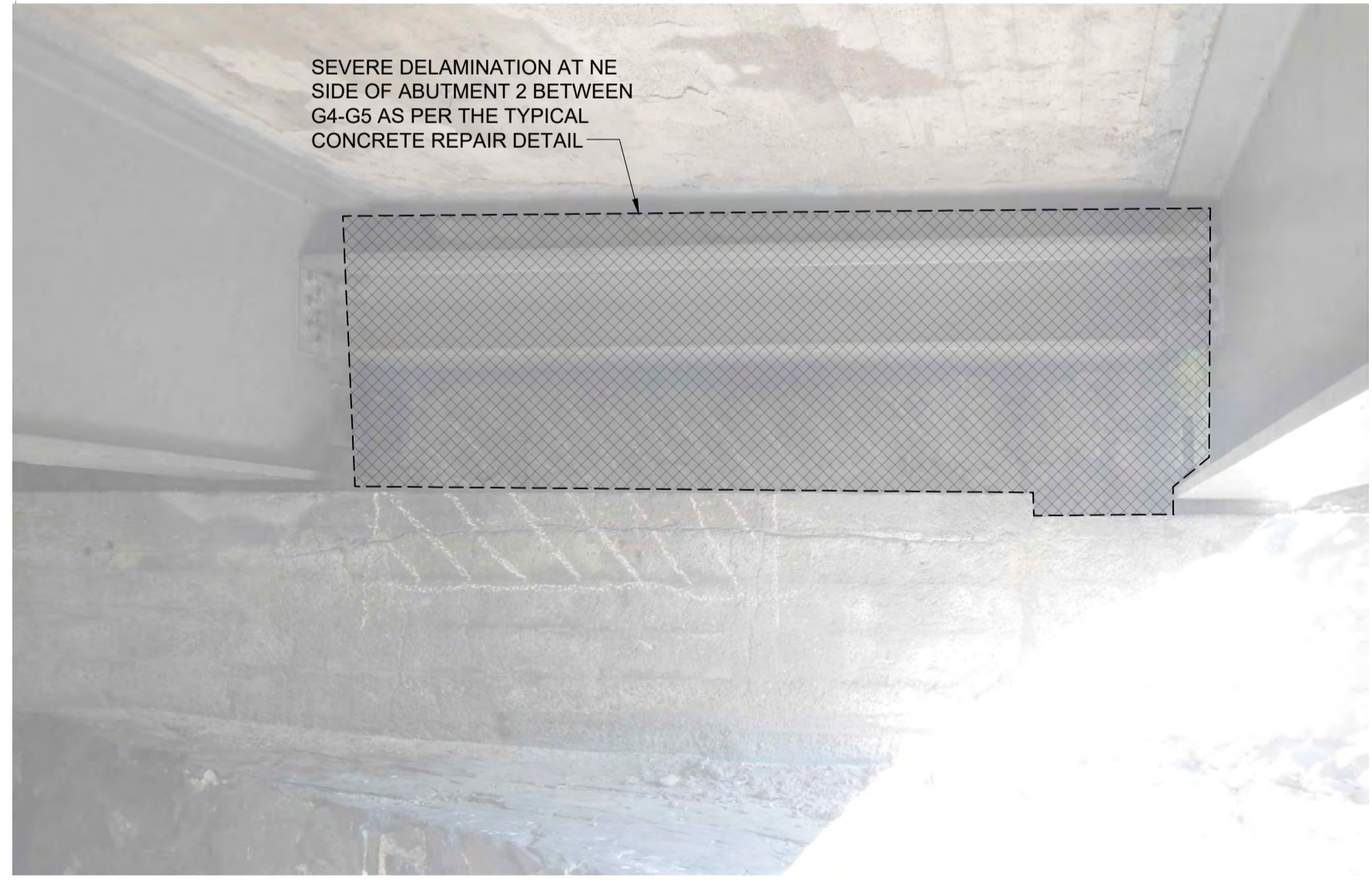

1 - BALLAST WALL REPAIR
NTS

- NOTES:**
- SEE SHEET 2 FOR GENERAL NOTES
 - SEE SHEET 2 FOR TYPICAL CONCRETE REPAIR DETAIL
 - SEE SHEET 2 FOR TYPICAL ASPHALT REPAIR DETAIL
- LEGEND**
- EXST POT HOLE IN CONCRETE
 - EXST EXPOSED REBAR
 - EXST DELAMINATION APPROX. EXTENTS
 - EXST CHIP
 - EXST SPALL
 - EXST SEVERE SCALING
 - TYPICAL CONCRETE REPAIR APPROX. EXTENT

METRIC

WHOLE NUMBERS INDICATE MILLIMETRES
DECIMALIZED NUMBERS INDICATE METRES

US: 13133944-0000 - Rev: 03 - Sheet: 03 - Includ: 13944-11-14-10m.dwg: 13 Parson Street Bridge 2026/05/20 12:16 PM By: steemack, James

Revision	By	Appd.	YY.MM.DD
5			
4			
3			
2			
1			
A	J.M.B.	E.R.T.	26.05.20
Issued			

Client/Project Logo

Permit-Seal

Stantec Consulting Ltd.
Suite 500, 311 Portage Avenue
Winnipeg MB Canada R3B 2B9
Tel. 204.489.5900 Fax. 204.453.9012
www.stantec.com

The Contractor shall verify and be responsible for all dimensions.
DO NOT scale the drawing - any errors or omissions shall be reported to Stantec without delay.
The Copyrights to all designs and drawings are the property of Stantec.
Reproduction or use for any purpose other than that authorized by Stantec is forbidden.

Client/Project
CITY OF KENORA, ONTARIO

BRIDGE MAINTENANCE REPAIRS

KENORA, ONTARIO

File Name: 33944-11-14-10m.dwg
J.M.B. Dwn.
T.M.H. Chkt.
E.R.T. Dgn.
2026.05.15
YY.MM.DD

Title
PARSON STREET BRIDGE
EXISTING CONDITIONS & REPAIR DETAILS

Project No. 113733944
Scale AS SHOWN

Drawing No. S-111
Sheet 13 of 20
Revision 0

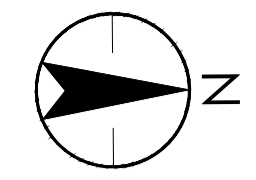
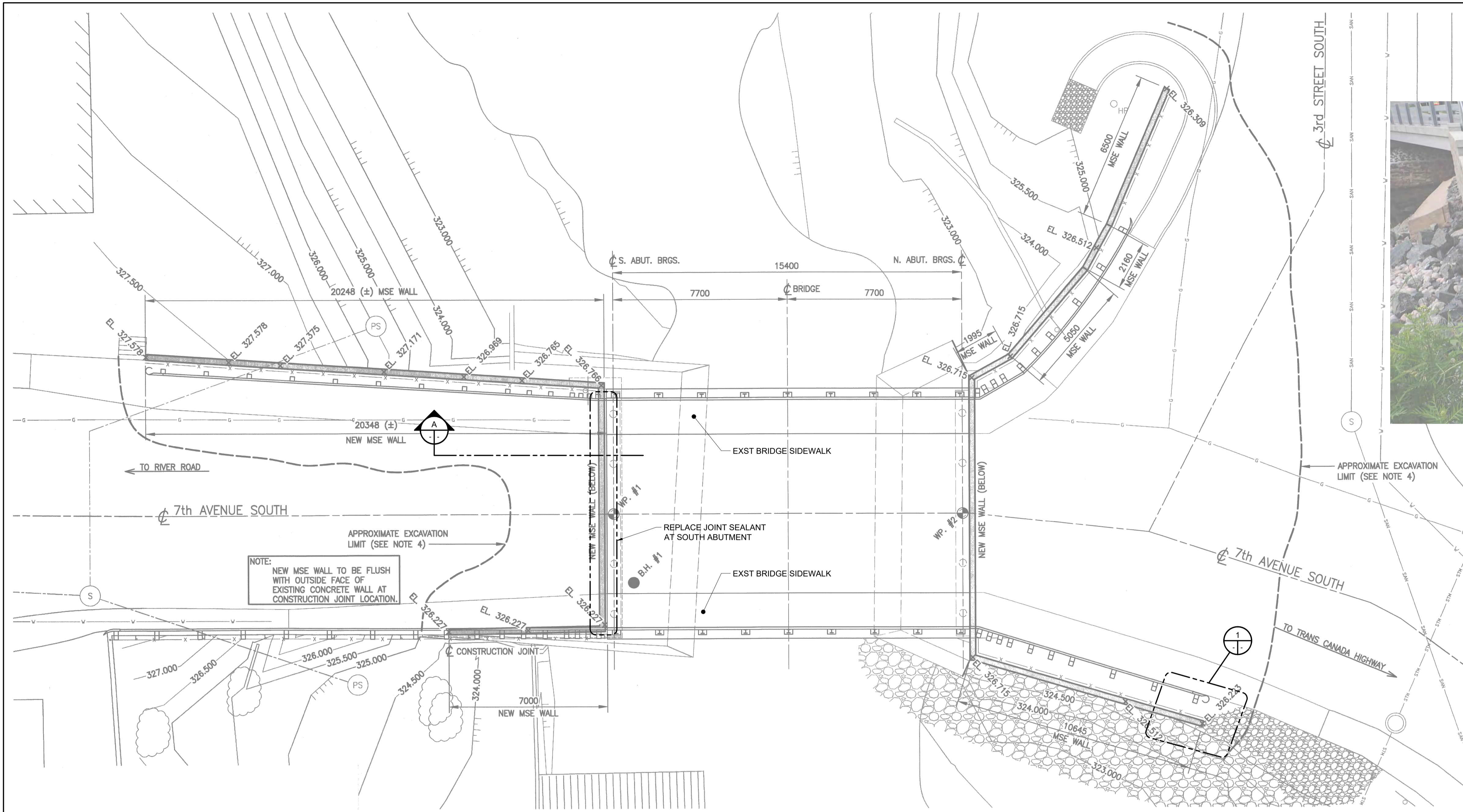

FORM AND GROUT VOID
FORM TOP OF SIDEWALK

1
-1
EMBAKMENT UNDERMINING
NTS

NOTE:
NEW MSE WALL TO BE FLUSH
WITH OUTSIDE FACE OF
EXISTING CONCRETE WALL AT
CONSTRUCTION JOINT LOCATION.

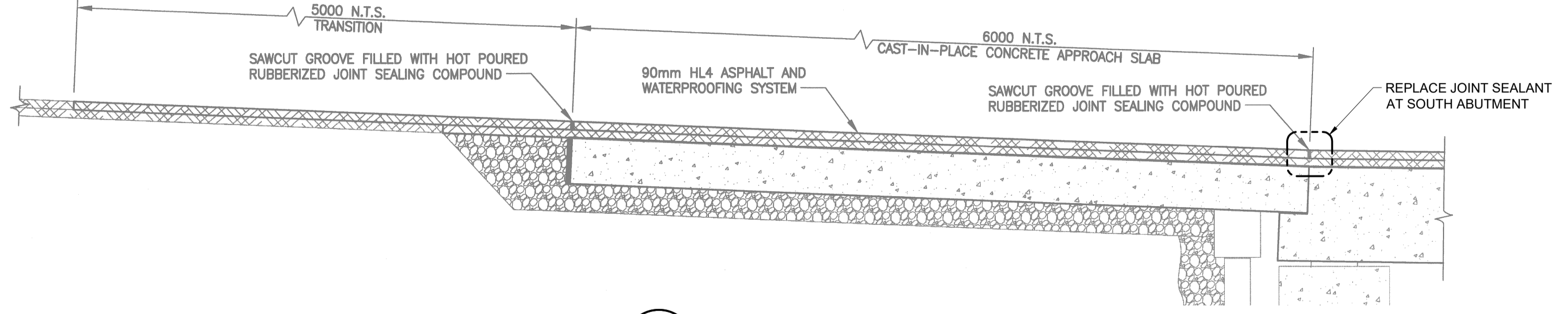

- NOTES:**
- SEE SHEET 2 FOR GENERAL NOTES
 - SEE SHEET 2 FOR TYPICAL CONCRETE REPAIR DETAIL
 - SEE SHEET 2 FOR TYPICAL ASPHALT REPAIR DETAIL
- LEGEND**
- EXST POTHOLE IN CONCRETE
 - ▨ EXST EXPOSED REBAR
 - ▨ EXST DELAMINATION APPROX. EXTENTS
 - ▨ EXST CHIP
 - ▨ EXST SPALL
 - ▨ EXST SEVERE SCALING
 - ▨ TYPICAL CONCRETE REPAIR APPROX. EXTENT

METRIC
WHOLE NUMBERS INDICATE MILLIMETRES
DECIMALIZED NUMBERS INDICATE METRES

US: 11373944-0390 - Rev: 0390 - Sheet: 03 - File: 03 - Location: 13944-03-1242km.dwg - 14 Seventh Avenue Bridge
 2024/05/20 12:20 PM By: steemans, James

Revision	By	Appd.	YY.MM.DD
5			
4			
3			
2			
1			
A	J.M.B.	E.R.T.	26.05.20
Issued	By	Appd.	YY.MM.DD

Client/Project Logo

Permit-Seal

Stantec Consulting Ltd.
Suite 500, 311 Portage Avenue
Winnipeg MB Canada R3B 2B9
Tel. 204.489.5900 Fax. 204.453.9012
www.stantec.com

The Contractor shall verify and be responsible for all dimensions.
DO NOT scale the drawing - any errors or omissions shall be reported to Stantec without delay.
The Copyrights to all designs and drawings are the property of Stantec.
Reproduction or use for any purpose other than that authorized by Stantec is forbidden.

Client/Project
CITY OF KENORA, ONTARIO

BRIDGE MAINTENANCE REPAIRS

KENORA, ONTARIO

File Name: 33944-1124km.dwg
J.M.B. Dwn.
T.M.H. Chkt.
E.R.T. Dgn.
2026.05.15
YY.MM.DD

Title
SEVENTH AVENUE BRIDGE
EXISTING CONDITIONS & REPAIR DETAILS

Project No. 11373944
Scale AS SHOWN

Drawing No. S-112
Sheet 14 of 20
Revision 0

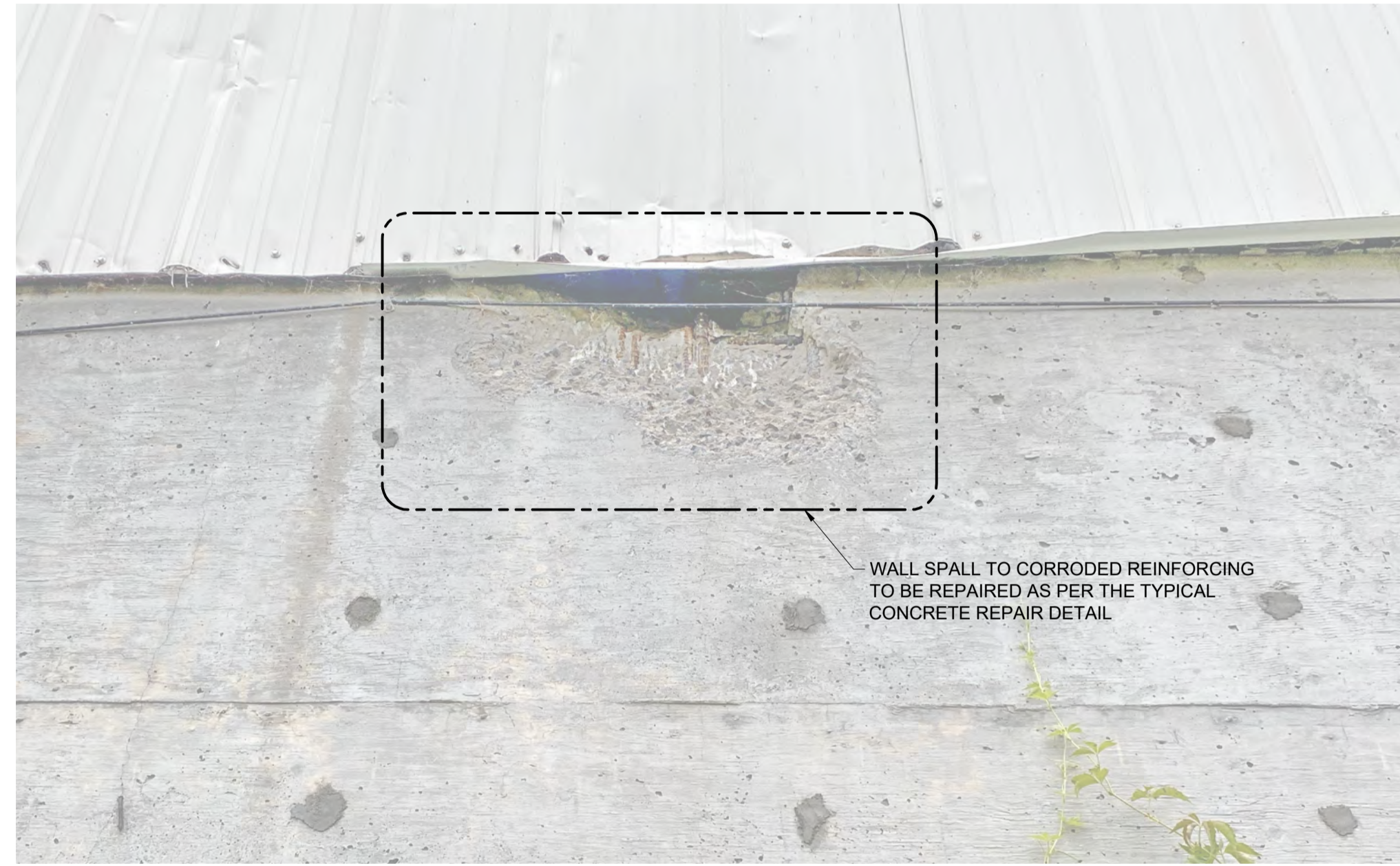
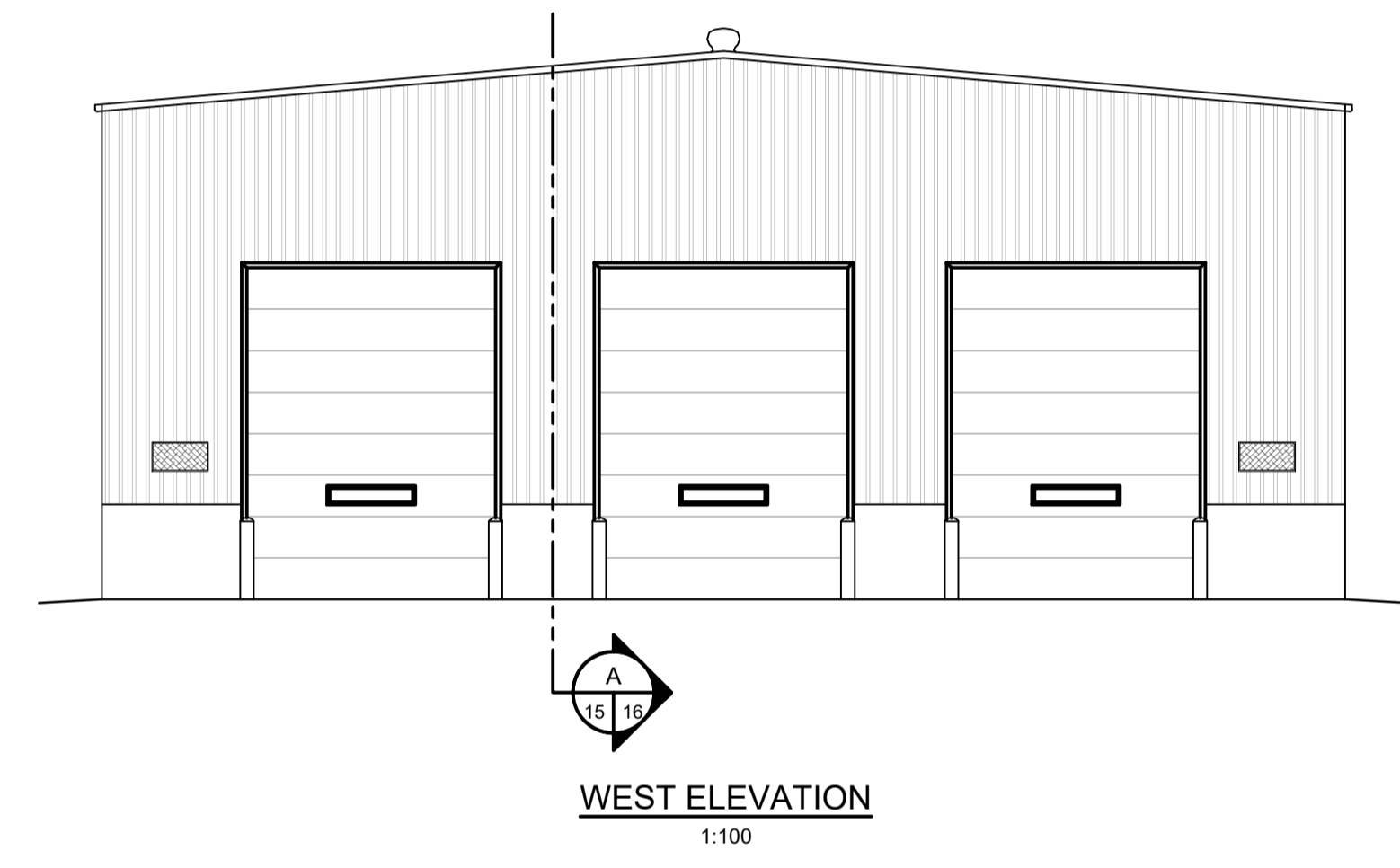
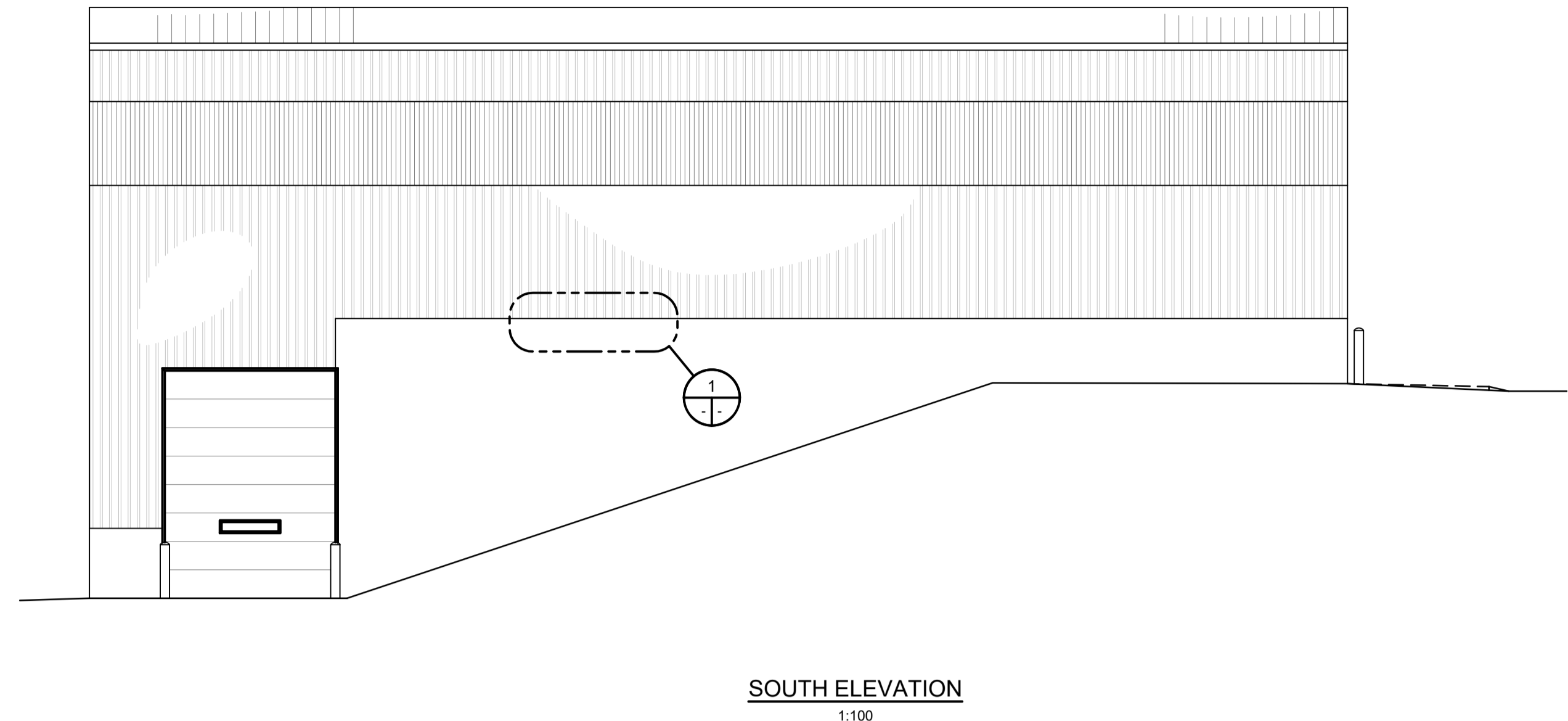
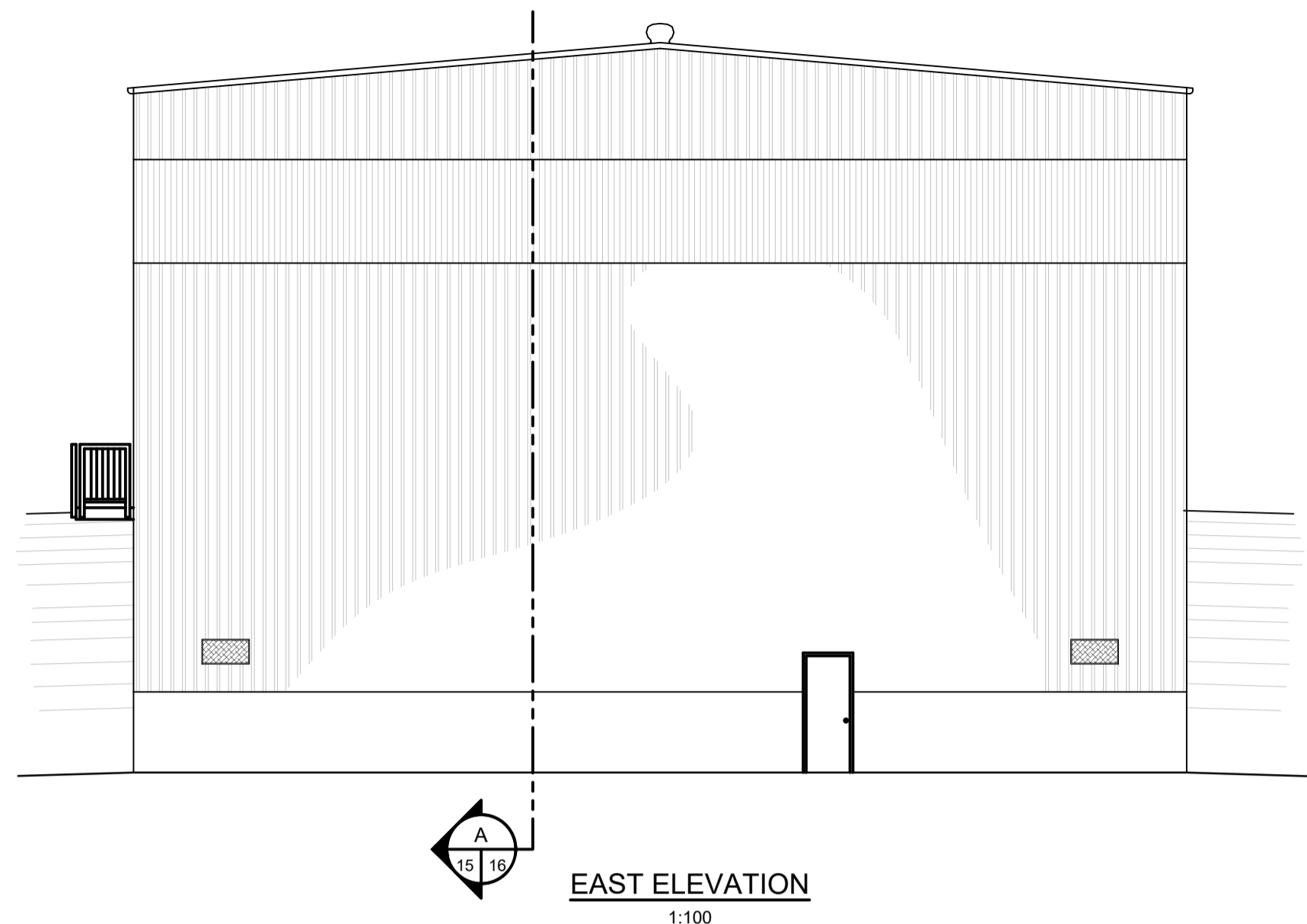

1
- -
NTS
SOUTH EXTERIOR WALL DAMAGED AREA DETAIL

NOTES:
SEE SHEET 2 FOR GENERAL NOTES
SEE SHEET 2 FOR TYPICAL CONCRETE REPAIR DETAIL
SEE SHEET 2 FOR TYPICAL ASPHALT REPAIR DETAIL

- LEGEND**
- EXST POT HOLE IN CONCRETE
 - EXST EXPOSED REBAR
 - EXST DELAMINATION APPROX. EXTENTS
 - EXST CHIP
 - EXST SPALL
 - EXST SEVERE SCALING
 - TYPICAL CONCRETE REPAIR APPROX. EXTENT

METRIC
WHOLE NUMBERS INDICATE MILLIMETRES
DECIMALIZED NUMBERS INDICATE METRES

US: 113733944_0000.dwg (Rev: 03) 2026.05.20 11:34am: 15 Waste Transfer Station 2026/05/20 12:24 PM By: steve.marks, James

Revision	By	Appd.	YY.MM.DD
5			
4			
3			
2			
1			
A	J.M.B.	E.R.T.	26.05.20
Issued	By	Appd.	YY.MM.DD

Client/Project Logo

Permit/Seal

Stantec Consulting Ltd.
Suite 500, 311 Portage Avenue
Winnipeg MB Canada R3B 2B9
Tel. 204.489.5900 Fax. 204.453.9012
www.stantec.com

The Contractor shall verify and be responsible for all dimensions.
DO NOT scale the drawing - any errors or omissions shall be reported to Stantec without delay.
The Copyrights to all designs and drawings are the property of Stantec.
Reproduction or use for any purpose other than that authorized by Stantec is forbidden.

Client/Project
CITY OF KENORA, ONTARIO

BRIDGE MAINTENANCE REPAIRS

KENORA, ONTARIO

File Name: 33944-1134bm.dwg
J.M.B. T.M.H. E.R.T. 2026.05.20
Dwn. Chkt. Dgn. YY.MM.DD

Title
WASTE TRANSFER STATION
ELEVATIONS & SECTION

Project No. 113733944
Scale AS SHOWN

Drawing No. S-113
Sheet 15 of 20
Revision 0

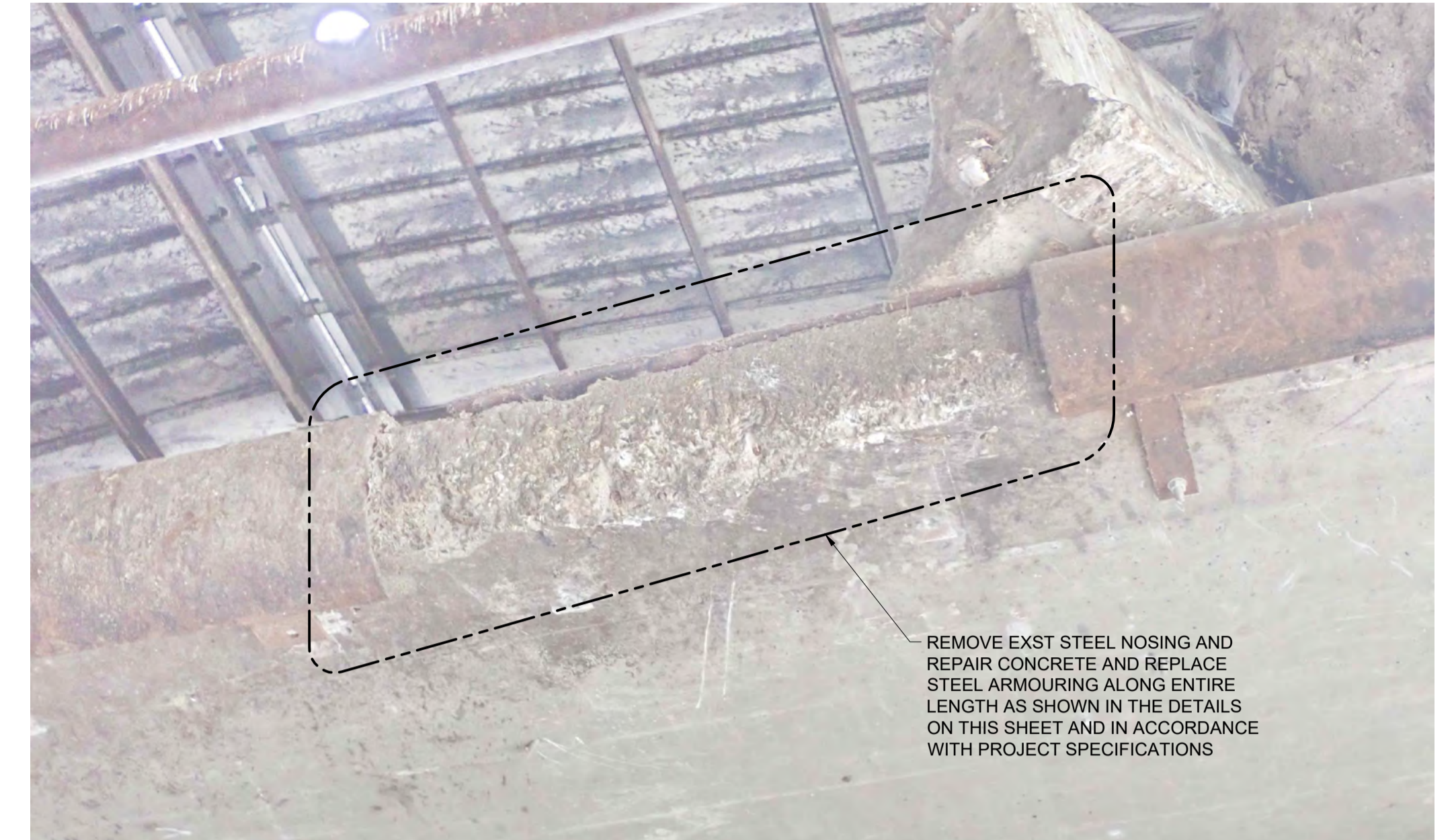
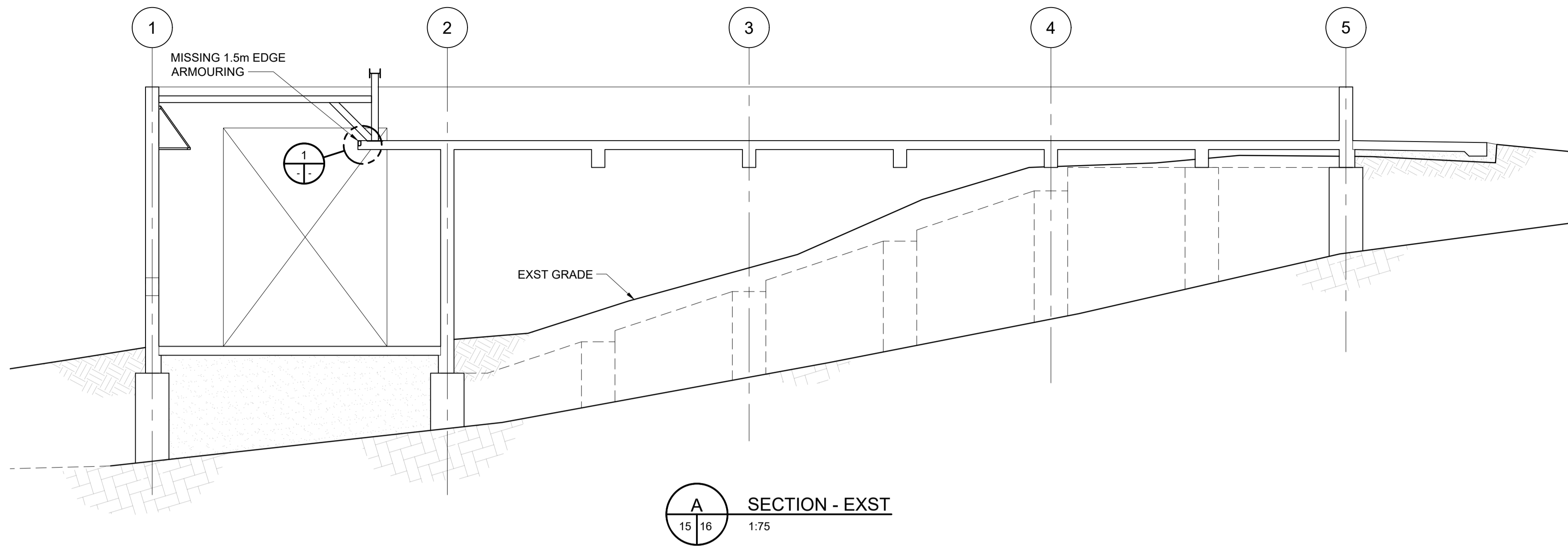

ARMOURING DAMAGED & MISSING
NTS

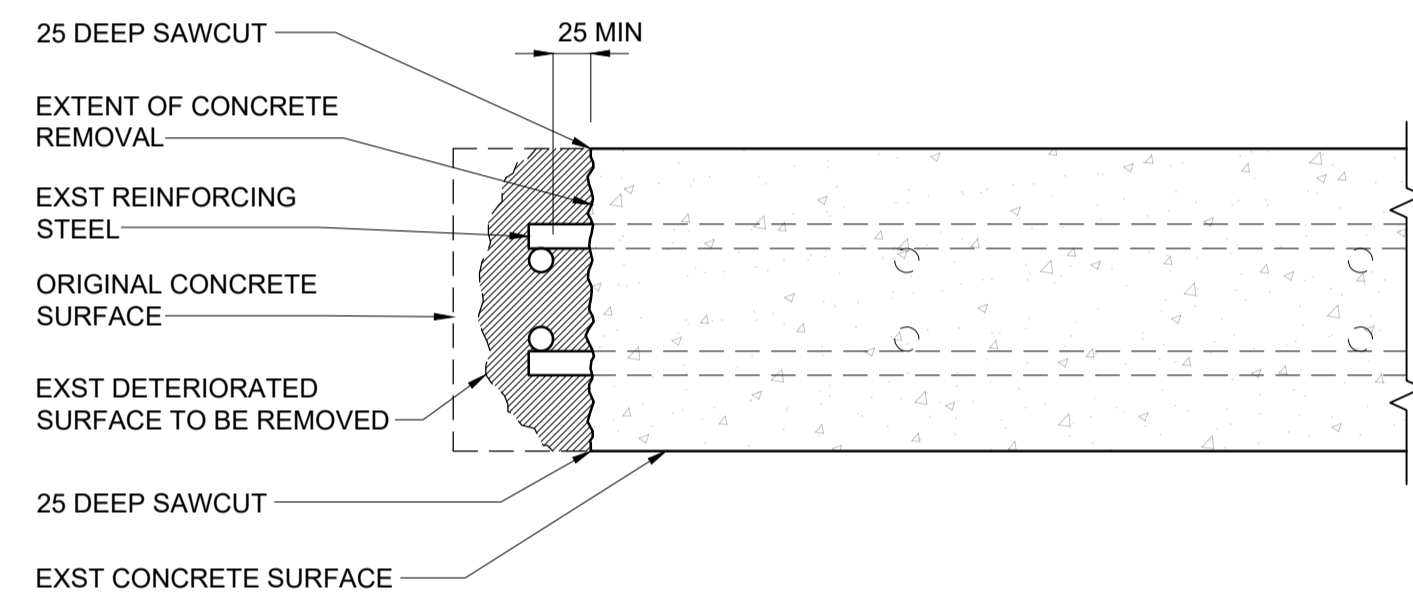

CONCRETE ARMOURING - DAMAGED DETAIL
1:5

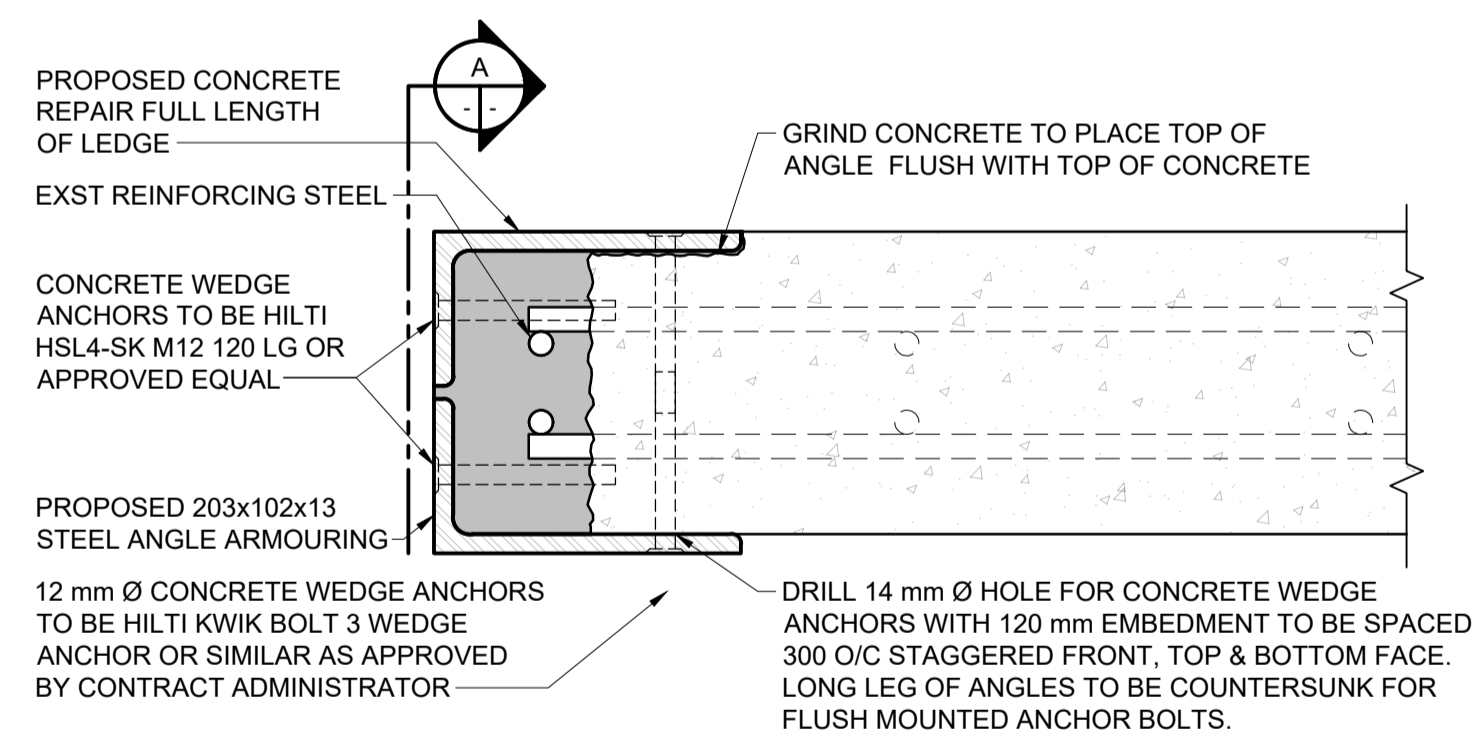

CONCRETE ARMOURING - REPAIR DETAIL
1:5

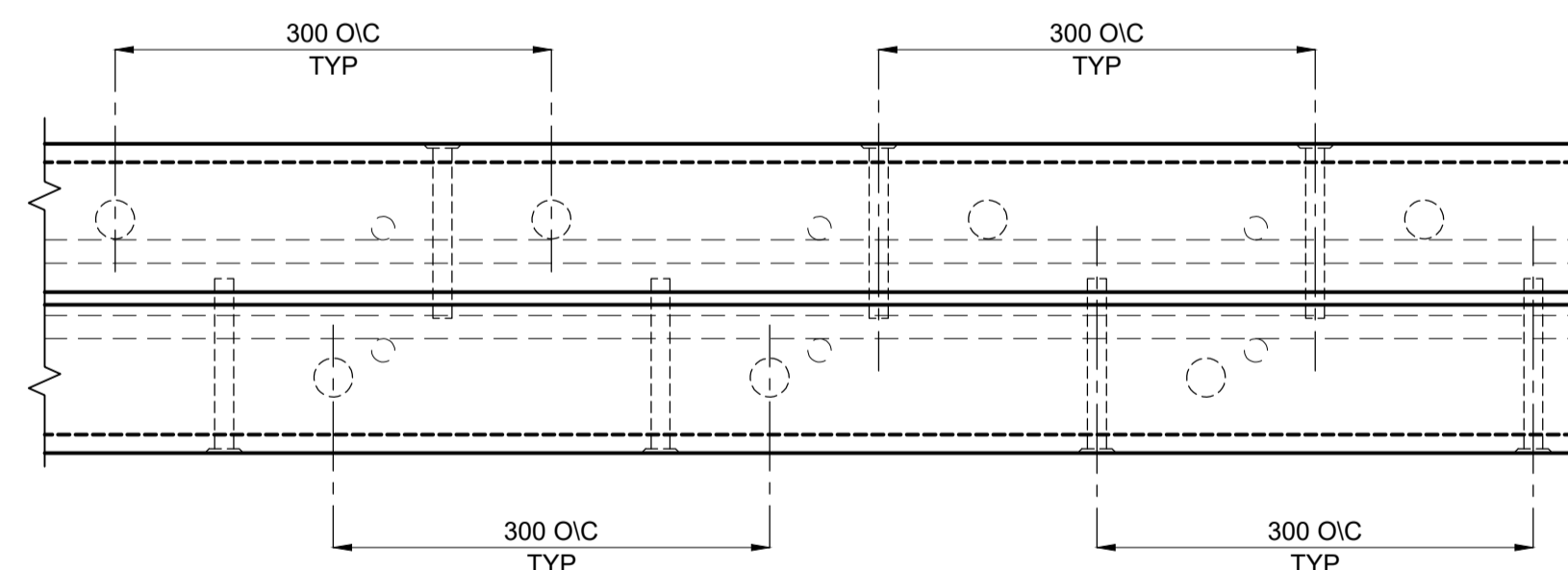

CONCRETE ARMOURING REPAIR DETAIL
1:5

NOTES:

- SEE SHEET 2 FOR GENERAL NOTES
- SEE SHEET 2 FOR TYPICAL CONCRETE REPAIR DETAIL
- SEE SHEET 2 FOR TYPICAL ASPHALT REPAIR DETAIL

LEGEND

- EXST POTHOLE IN CONCRETE
- ▨ EXST EXPOSED REBAR
- ▤ EXST DELAMINATION APPROX. EXTENTS
- ▥ EXST CHIP
- ▧ EXST SPALL
- ▩ EXST SEVERE SCALING
- TYPICAL CONCRETE REPAIR APPROX. EXTENT

METRIC

WHOLE NUMBERS INDICATE MILLIMETRES
DECIMALIZED NUMBERS INDICATE METRES

5				
4				
3				
2				
1				
Revision	By	Appd.	YY.MM.DD	
E				
D				
C				
B				
A	J.M.B.	E.R.T.	26.05.20	
Issued	By	Appd.	YY.MM.DD	

Client/Project Logo



Permit-Seal



Stantec Consulting Ltd.
Suite 500, 311 Portage Avenue
Winnipeg MB Canada R3B 2B9
Tel. 204.489.5900 Fax. 204.453.9012
www.stantec.com

The Contractor shall verify and be responsible for all dimensions.
DO NOT scale the drawing - any errors or omissions shall be reported to Stantec without delay.
The Copyrights to all designs and drawings are the property of Stantec.
Reproduction or use for any purpose other than that authorized by Stantec is forbidden.

Client/Project

CITY OF KENORA, ONTARIO

BRIDGE MAINTENANCE REPAIRS

KENORA, ONTARIO

File Name: 33944-1134bm.dwg

J.M.B.

T.M.H.

E.R.T.

2026.05.20

Dwn.

Chkt.

Dign.

YY.MM.DD

Title

WASTE TRANSFER STATION
SECTIONS & DETAILS

Project No.

113733944

Scale

AS SHOWN

Drawing No.

S-114

Sheet

16 of 20

Revision

0

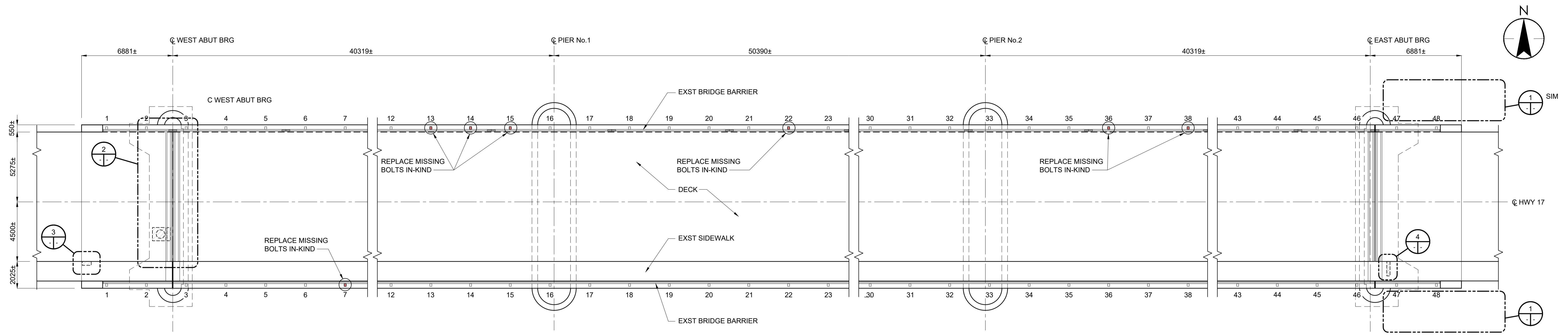

BRIDGE PLAN
1:150



1 CONDUIT DETAIL
NTS
SOUTH EAST EMBANKMENT SHOWN
NORTH EAST EMBANKMENT SIMILAR

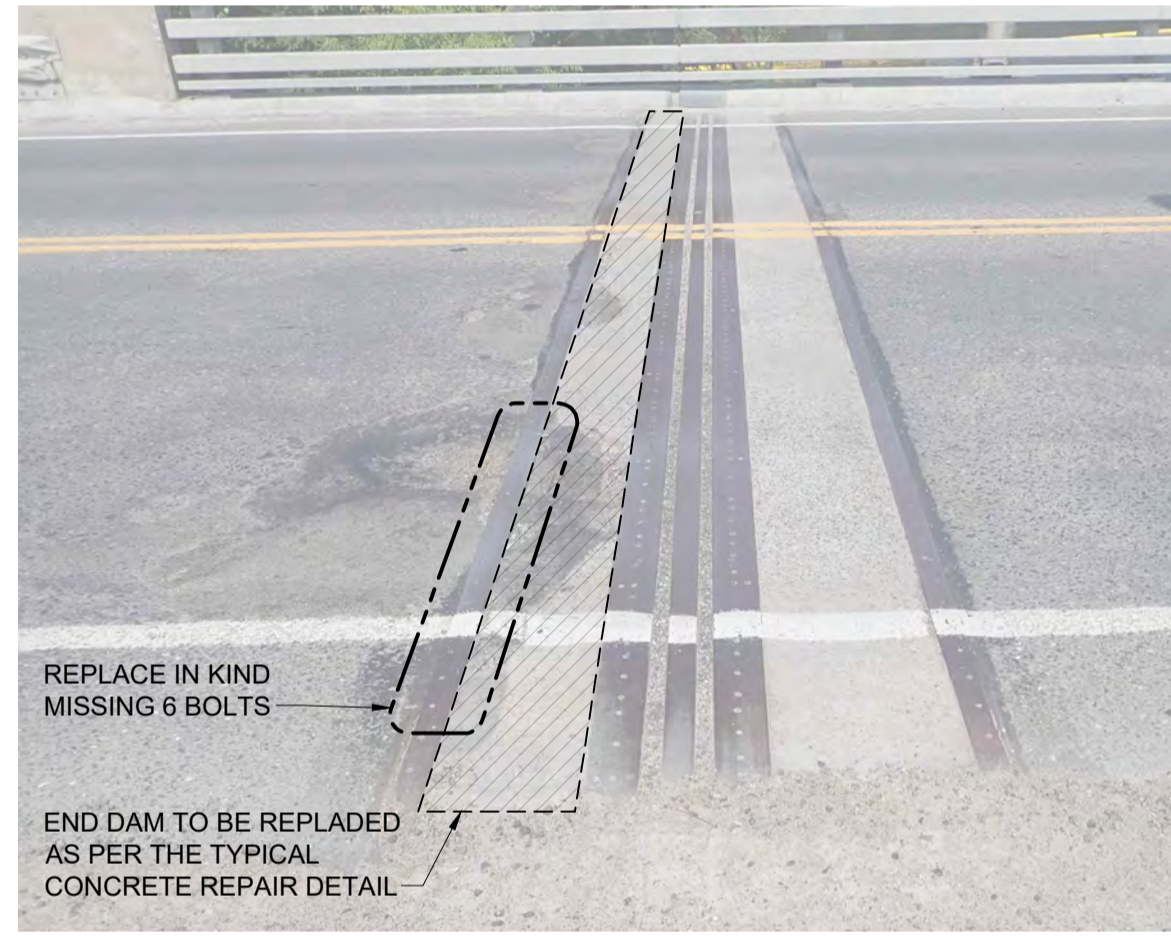

2 CONDITION DETAIL
NTS

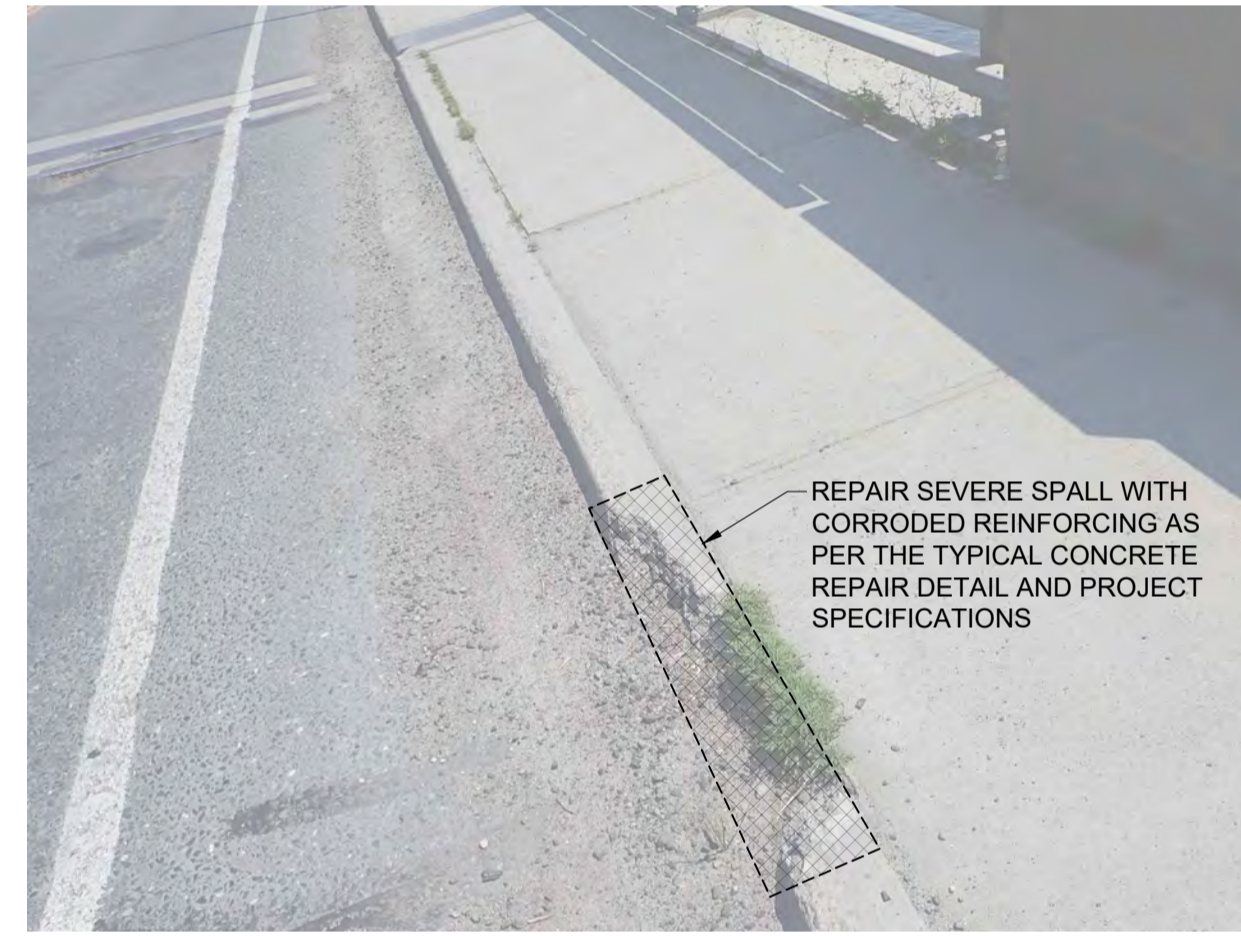

3 CONDITION DETAIL
NTS

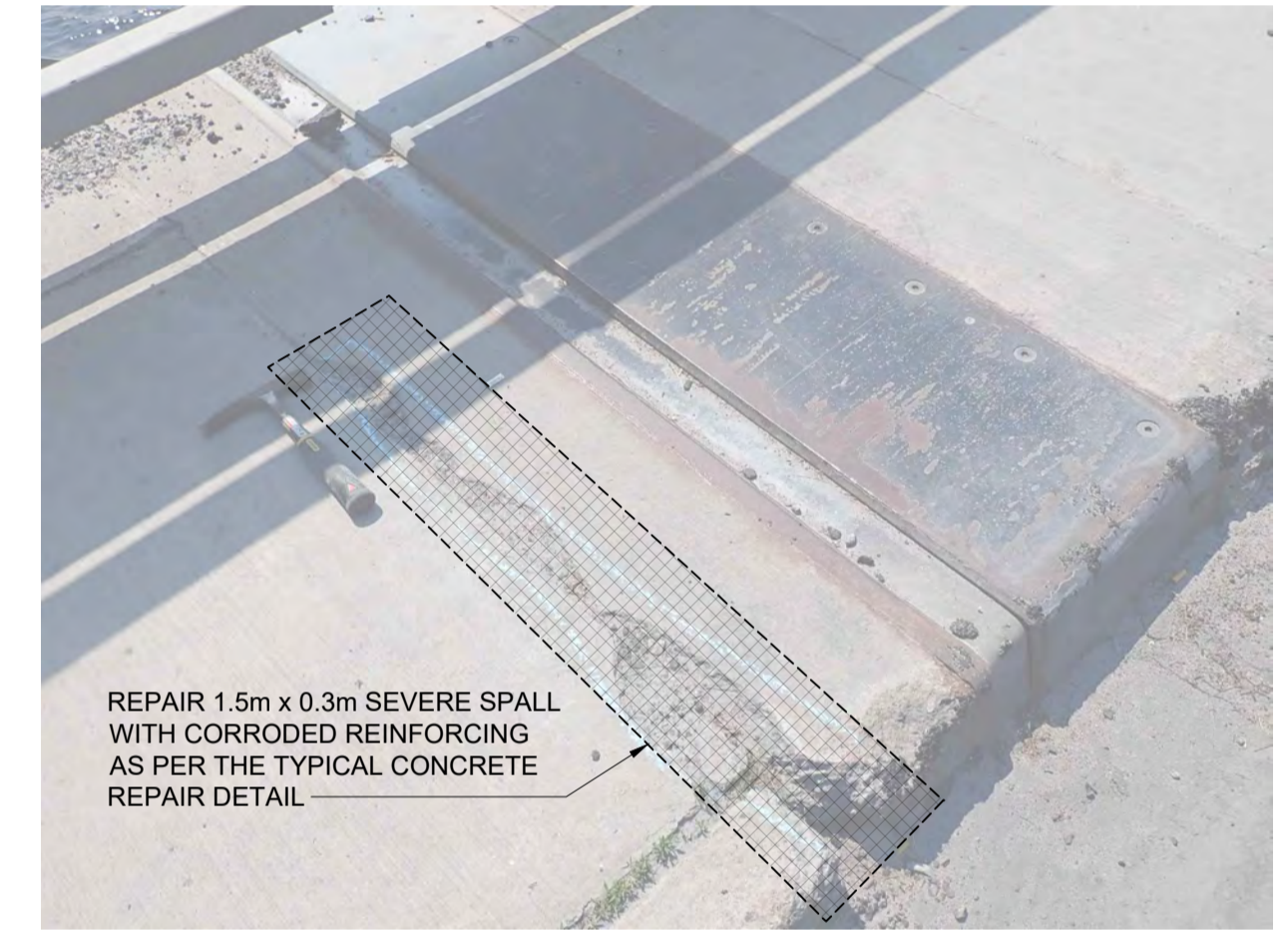

4 CONDITION DETAIL
NTS

NOTES:

- SEE SHEET 2 FOR GENERAL NOTES
- SEE SHEET 2 FOR TYPICAL CONCRETE REPAIR DETAIL
- SEE SHEET 2 FOR TYPICAL ASPHALT REPAIR DETAIL

LEGEND

- EXST POTHOLE IN CONCRETE
- EXST EXPOSED REBAR
- EXST DELAMINATION APPROX. EXTENTS
- EXST CHIP
- EXST SPALL
- EXST SEVERE SCALING
- TYPICAL CONCRETE REPAIR APPROX. EXTENT

METRIC

WHOLE NUMBERS INDICATE MILLIMETRES
DECIMALIZED NUMBERS INDICATE METRES

Revision	By	Appd.	YY.MM.DD
5			
4			
3			
2			
1			
A	J.M.B.	E.R.T.	26.05.20
Issued			

Client/Project Logo



Permit-Seal



Stantec Consulting Ltd.
Suite 500, 311 Portage Avenue
Winnipeg MB Canada R3B 2B9
Tel. 204.489.5900 Fax. 204.453.9012
www.stantec.com

The Contractor shall verify and be responsible for all dimensions.
DO NOT scale the drawing - any errors or omissions shall be reported to Stantec without delay.
The Copyrights to all designs and drawings are the property of Stantec.
Reproduction or use for any purpose other than that authorized by Stantec is forbidden.

Client/Project
CITY OF KENORA, ONTARIO

BRIDGE MAINTENANCE REPAIRS

KENORA, ONTARIO

File Name: 33944-1154bm.dwg J.M.B. T.M.H. E.R.T. 2026.05.15
Dwn. Chkt. Dgn. YY.MM.DD

Title
WINNIPEG RIVER EAST BRIDGE
EXISTING CONDITIONS & REPAIR DETAILS

Project No. 113733944 Scale AS SHOWN

Drawing No. S-115 Sheet 17 of 20 Revision 0

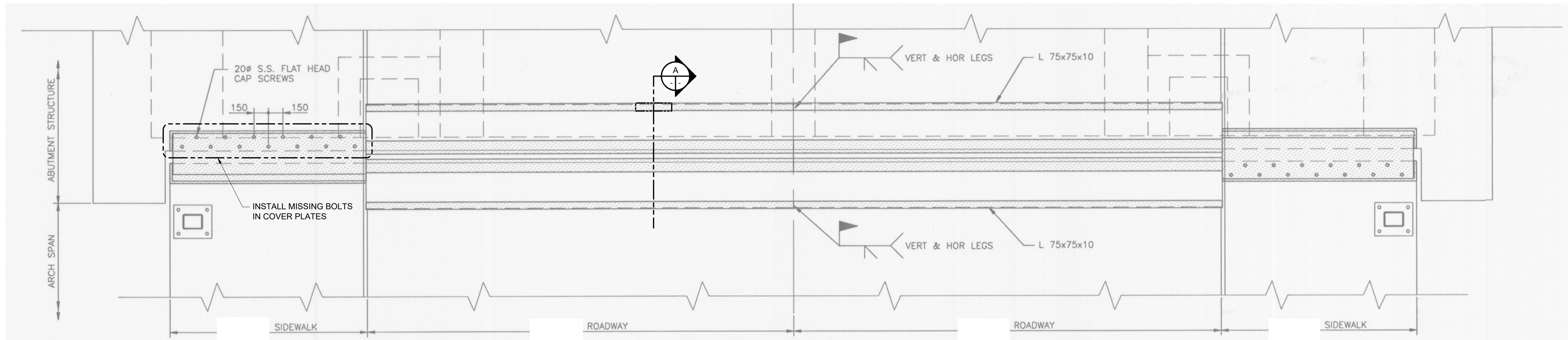

1 DAMAGED ARMOURING STEEL ANGLE AT JOINT 1
1:25

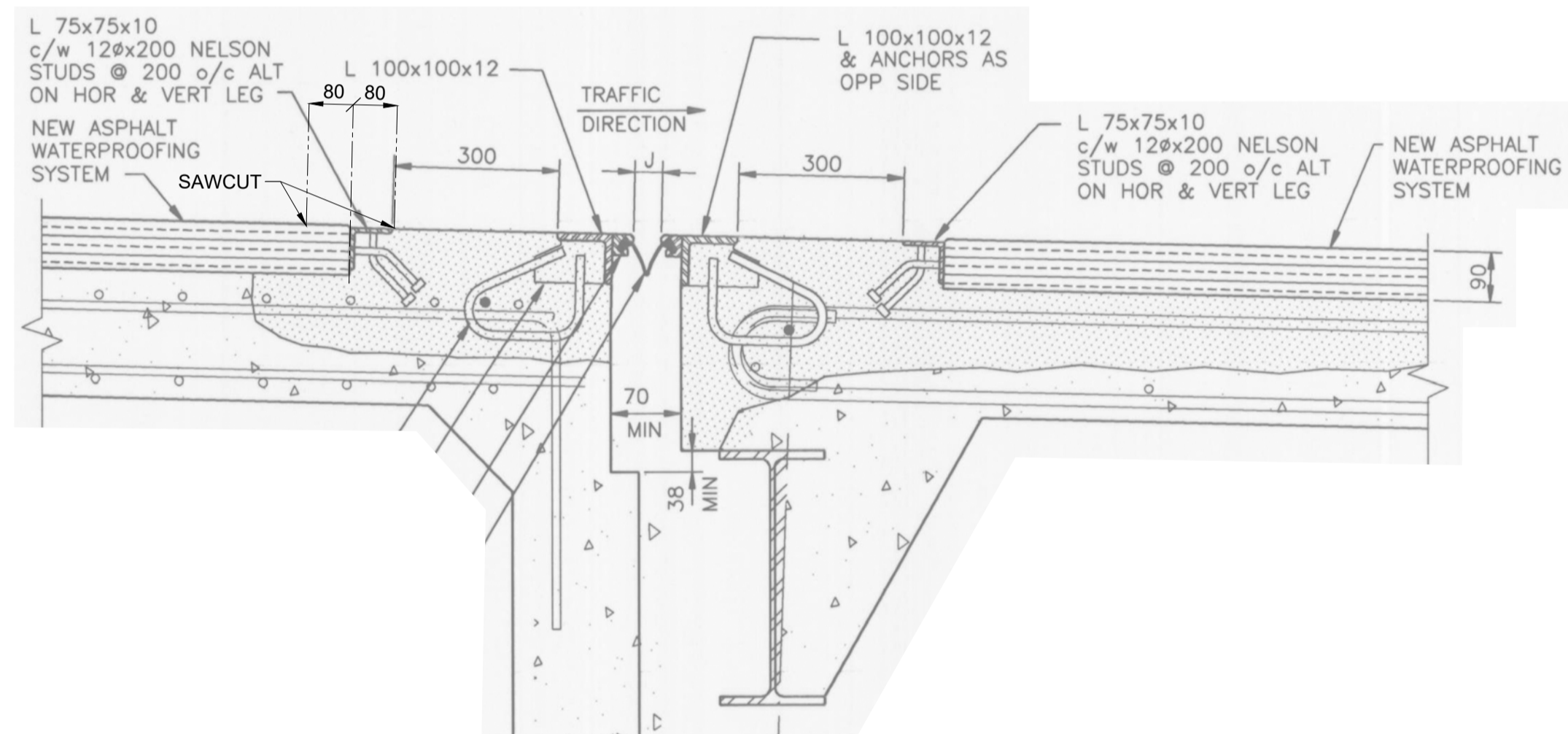

LEVEL WITH CONCRETE GRINDER AND REPLACE JOINT SEAL AS REQUIRED

2 SOUTH EAST APPROACH
NTS

REPAIR NOTES:

1. SAW CUT TO REMOVE EXISTING BROKEN ANGLE AS SHOWN IN THE DETAIL ABOVE. ANY EXPOSED ANCHOR STUDS ARE TO BE CUT DOWN AND REMOVED AS REQUIRED.
2. REMOVE 80 mm OF ASPHALT AND 80 mm OF CONCRETE ADJACENT TO EACH SIDE OF STEEL ANGLE.
3. REPLACE ANGLE SECTION IN-KIND WITH NEW WELDED ANCHORS AS REQUIRED. WEARING SURFACE OF ANGLE TO BE GROUND FLUSH WITH EXISTING STEEL.
4. REFER TO CONCRETE AND ASPHALT REPAIR DETAIL TO REPAIR CONCRETE ADJACENT TO STEEL ANGLE

A ARMOUR REPAIR DETAIL
NTS

NOTES:

- SEE SHEET 2 FOR GENERAL NOTES
- SEE SHEET 2 FOR TYPICAL CONCRETE REPAIR DETAIL
- SEE SHEET 2 FOR TYPICAL ASPHALT REPAIR DETAIL

LEGEND

- EXST POTHOLE IN CONCRETE
- EXST EXPOSED REBAR
- EXST DELAMINATION APPROX. EXTENTS
- EXST CHIP
- EXST SPALL
- EXST SEVERE SCALING
- TYPICAL CONCRETE REPAIR APPROX. EXTENT

METRIC

WHOLE NUMBERS INDICATE MILLIMETRES
DECIMALIZED NUMBERS INDICATE METRES

US: 113733944_0000_Rev03.dwg (Rev. 03) - Includ: 1164km.dwg; 19 Winnipeg River West Bridge
 2024/05/20 1:37 PM By: Rseemore, James

Revision	By	Appd.	YY.MM.DD
5			
4			
3			
2			
1			
A	J.M.B.	E.R.T.	26.05.20
Issued			

Client/Project Logo

Permit-Seal

Stantec Consulting Ltd.
 Suite 500, 311 Portage Avenue
 Winnipeg MB Canada R3B 2B9
 Tel. 204.489.5900 Fax. 204.453.9012
 www.stantec.com

The Contractor shall verify and be responsible for all dimensions.
 DO NOT scale the drawing - any errors or omissions shall be reported to Stantec without delay.
 The Copyrights to all designs and drawings are the property of Stantec.
 Reproduction or use for any purpose other than that authorized by Stantec is forbidden.

Client/Project
 CITY OF KENORA, ONTARIO

BRIDGE MAINTENANCE REPAIRS

KENORA, ONTARIO

File Name: 33944-1164km.dwg
 J.M.B. Dwn.
 T.M.H. Chkt.
 E.R.T. Dgn.
 2026.05.15

Title
 WINNIPEG RIVER WEST BRIDGE
 EXISTING CONDITIONS & REPAIR DETAILS
 SHEET 2 OF 2

Project No. 113733944
 Scale AS SHOWN

Drawing No. S-117
 Sheet 19 of 20
 Revision 0

